

**ZEUS** HYDRATECH LTD  
*Global Suppliers of Premium Hydraulic Components*

**UK sales for all Casappa pumps & motors**

T: +44(0)1172 130042. E: [sales@zeushydratech.com](mailto:sales@zeushydratech.com). W: [zeushydratech.com](http://zeushydratech.com)

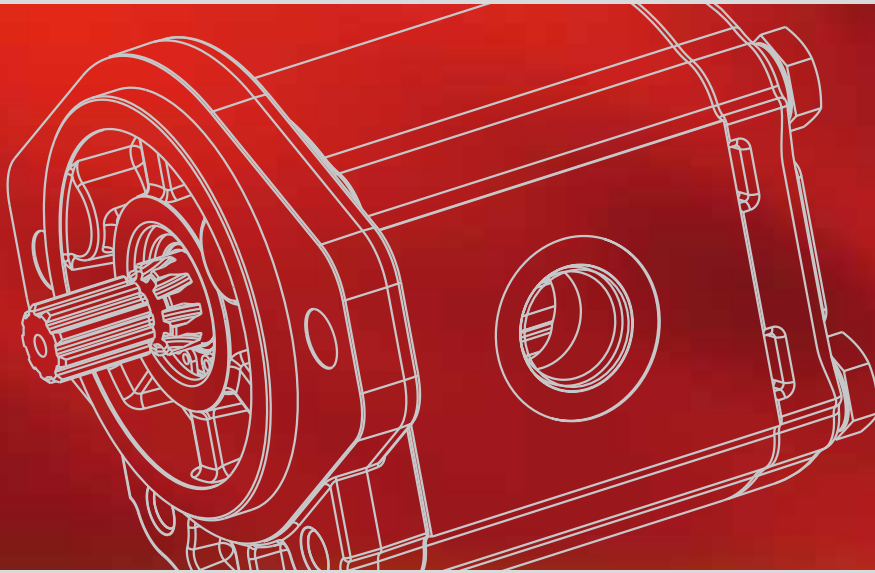

HYDRAULIC GEAR  
PUMPS AND  
MOTORS

**POLARIS**<sup>®</sup>

# INDEX

Section	Page
INTRODUCTION.....	3
INSTRUCTIONS .....	4
FEATURES.....	5
GEAR PUMPS PERFORMANCE CURVES.....	9
GEAR MOTORS PERFORMANCE CURVES .....	21
SINGLE UNITS DIMENSIONS.....	34
MULTIPLE PUMPS.....	39
MULTIPLE PUMPS DIMENSIONS.....	44
OUTBOARD BEARING OPTIONS .....	48
VERSION WITH OUTBOARD BEARING.....	49
DRIVE SHAFTS.....	52
MOUNTING FLANGES AND TABLE OF COMPATIBILITY .....	58
PORTS POSITION AND TYPE.....	70
PORTS SIZE .....	72
VALVE OPTIONS.....	76
HOW TO ORDER POLARIS SINGLE UNITS .....	78
HOW TO ORDER POLARIS MULTIPLE PUMPS.....	84
HOW TO ORDER POLARIS DOUBLE PUMPS DIFFERENT GROUPS .....	90

04/10.2020

**Modification from former edition.**

## INTRODUCTION

“POLARIS” more than fifty years of Casappa experience in design and production of hydraulic components, characterized by large investments in research and development in order to propose new and personalized solutions to the market.

Our use of CAD 3D in the development of this generation permit us the 3D modelling and the virtual simulation of the behaviour of the components inserted in the hydraulic circuit. This means that the process will take less time and the quality of the products is better.

Polaris pumps and motors are basically composed of a gear housing in aluminium alloy, two gear wheels supported by sleeve bearings and two end plates, the front and the rear cover, either in aluminium or in cast iron with excellent mechanical characteristics.

Our success is based largely on the quality of our product. This guaranties the consistencies of the efficiencies and low level of noise emission during the life of our products.

Replaces: 02/07.2006

### DISPLACEMENTS

From 1,07 cm<sup>3</sup>/rev (0.07 in<sup>3</sup>/rev)  
To 91,10 cm<sup>3</sup>/rev (5.56 in<sup>3</sup>/rev)

### PRESSURE

Max. constant operating pressure 260 bar (3770 psi)  
Max. system pressure (relief valve setting) 280 bar (4060 psi)  
Max. peak of pressure 300 bar (4350 psi)

### SPEED

Max. 4000 min<sup>-1</sup>

- Available in groups 10, 20 and 30.
- Drive shafts, mounting flanges and ports according to the international standards.
- Combination of multiple pumps in standard version, common inlet and separated stages.
- Integrated outboard bearings for heavy duty application.
- Many types of built-in valves.

### TYPICAL APPLICATIONS

- Building & Construction
- Material Handling
- Agriculture
- Forestry
- Turf care & Mowers
- Fan Drive

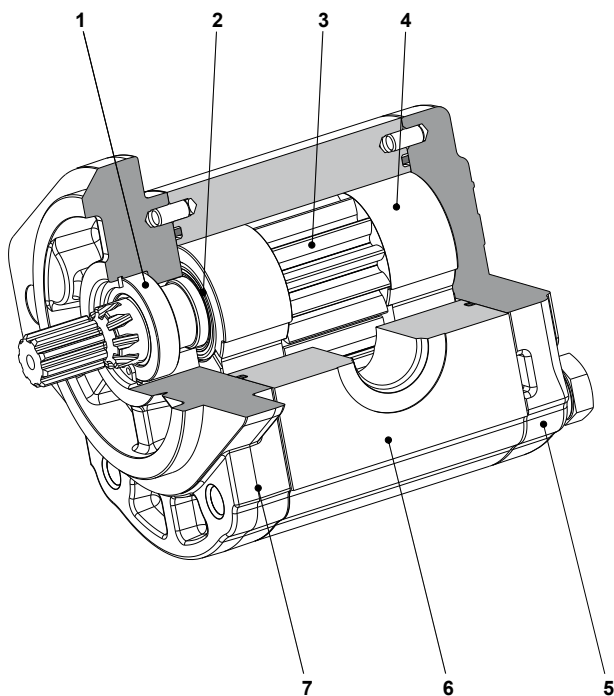

04/10.2020

1	Shaft seal
2	Seal
3	Gear
4	Thrust plate
5	Rear cover
6	Body
7	Mounting flange



# INSTRUCTIONS

## INSTALLATION

### Pump

The direction of rotation of single-rotation pumps must be the same as that of the drive shaft. Check that the coupling flange correctly aligns the transmission shaft and the pump shaft. Flexible couplings should be used (never rigid fittings) which will not generate an axial or radial load on the pump shaft.

### Motor

The direction of rotation of single-rotation motors must match circuit connections. Check that the coupling flange correctly aligns the transmission shaft and the motor shaft. Flexible couplings should be used (never rigid fittings) which will not generate an axial or radial load on the motor shaft.

### TANK

Tank capacity must be sufficient for the system's operating conditions ( ~ 3 times the amount of oil in circulation) to avoid overheating of the fluid. A heat exchanger should be installed if necessary. The intake and return lines in the tank must be spaced apart (by inserting a vertical divider) to prevent the return-line oil from being taken up again immediately.

### LINES

The lines must have a major diameter which is at least as large as the diameter of pump or motor ports, and must be perfectly sealed. To reduce loss of power, the lines should be as short as possible, reducing the sources of hydraulic resistance (elbow, throttling, gate valves, etc.) to a minimum. A length of flexible tubing is recommended to reduce the transmission of vibrations. All return lines must end below the minimum oil level, to prevent foaming. Before connecting the lines, remove any plugs and make sure that the lines are perfectly clean.

### HYDRAULIC FLUID

Use hydraulic fluid conforming to viscosity data as specified in the first pages of the catalogue. Avoid using mixtures of different oils which could result in decomposition and reduction of the oil's lubricating power.

### FILTERS

We recommend filtering the entire system flow. Filters on suction and return line must be fitted in according to the contamination class as indicated in the first pages of the catalogue. Casappa recommends to use its own production filters:



## STORAGE

The storage must be in a dry environment. Max storage time in ideal conditions is 24 months. The ideal storage temperature is between 5 °C (41 °F) and 20 °C (68 °F). No problem in case of temperature between -40 °C (-40 °F) and 50 °C (122 °F). Below -40 °C (-40 °F) please consult our pre-sales department.

## STARTING UP

Check that all circuit connections are tight and that the entire system is completely clean. Insert the oil in the tank, using a filter. Bleed the circuit to assist in filling. Set the pressure relief valves to the lowest possible setting. Turn on the system for a few moments at minimum speed, then bleed the circuit again and check the level of oil in the tank.

If the difference between pump or motor temperature and fluid temperature exceeds 10 °C (50 °F), rapidly switch the system on and off to heat it up gradually. Then gradually increase the pressure and speed of rotation until the pre-set operating levels as specified in the catalogue are attained.

## COLD START

Cold start is meant short term and low idle. During cold start of the machine the following limits can be applied:

Minimum inlet pressure	0,5 bar abs. (7 psi)
Outlet pressure (pumps) Inlet pressure (motors)	≤ 50 bar (725 psi)
Max drain pressure / Max back pressure for single rotation motors	+ 50% of standard values
Speed	≤ 1500 min <sup>-1</sup>
Minimum temperature	-40 °C (-40 °F)
Max oil viscosity	2000 mm <sup>2</sup> /s (cSt) [9100 SSU]

If the ambient temperature is lower than -20 °C (-4 °F) the system speed and pressure must be limited until the hydraulic oil temperature exceeds -20 °C (-4 °F).

## PERIODICAL CHECKS - MAINTENANCE

Keep the outside surface clean especially in the area of the drive shaft seal. In fact, abrasive powder can accelerate wear on the seal and cause leakage. Replace filters regularly to keep the fluid clean. The oil level must be checked and oil replaced periodically depending on the system's operating conditions.



Replaces: 02/07.2006

 04/10.2020

## FEATURES

Replaces: 02/07.2006

Construction	External gear pumps and motors 3-piece construction
Mounting	EUROPEAN - SAE - GERMAN standard flanges
Ports	Threaded or flanged
Direction of rotation (looking on drive shaft)	Anti-clockwise (S) - clockwise (D) - reversible external drain (R - L) reversible internal drain (B)
Inlet pressure range for pumps	0,7 ÷ 3 bar abs. (10 ÷ 44 psi) If p > 1,5 bar abs. (22 psi) specific shaft sealing have to be applied. Please consult our pre-sales department.
Max back pressure for single rotation motors	5 bar (73 psi) continuous @ min. speed 350 min <sup>-1</sup> 1 bar (14.5 psi) continuous @ max. speed (see page 7)
Max drain line pressure on reversible rotation motors	5 bar (73 psi) continuous @ min. speed 350 min <sup>-1</sup> 1 bar (14.5 psi) continuous @ max. speed (see page 7)
Max back pressure on in series motors	150 bar (2175 psi)
Fluid temperature range	See table (1)
Fluid	Mineral oil based hydraulic fluids to ISO/DIN. For other fluids please consult our pre-sales department
Viscosity range	From 12 to 100 mm <sup>2</sup> /s (cSt) [60 to 456 SSU] recommended Up to 750 mm <sup>2</sup> /s (cSt) [3410 SSU] permitted
Filtering requirement and recommended fluid contamination	See table (2) page 6

**Tab. 1** ○

Type	Fluid composition	Max pressure bar (psi)	Max speed min <sup>-1</sup>	Temperature - °C (°F)			Seals (●)	Shaft seals option (◆)
				Min	Max continuous	Max peak		
ISO/DIN	Mineral oil based hydraulic fluid to ISO/DIN	See page 7	See page 7	-25 (-13)	80 (176)	100 (212)	<b>N</b>	<b>D</b> <b>C1</b>
				-25 (-13)	110 (230)	125 (257)	<b>V</b>	
				-25 (-13)	110 (230)	125 (257)	<b>T-PV</b>	

(●) **N** = Buna NBR (standard) - **V** = Viton-FKM - **T-PV** = Hydrogenated buna HNBR seals with Viton-FKM shaft seals (only for PLP20)

04/10.2020 ○

○ **D** (◆) shaft seals with wiper seal **C1** (◆) High pressure special shaft seal

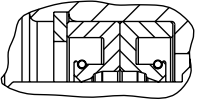
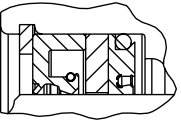
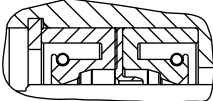
Single rotation pumps	Max drain line pressure: 0,5 bar (7 psi)		Max drain line pressure: 10 bar (145 psi) @ 350 min <sup>-1</sup>	
Single rotation motors Reversible rotation pumps and motors	Max drain line pressure: 5 bar (73 psi) @ 350 min <sup>-1</sup>			

## FEATURES

### Filtration

Casappa recommends to use its own production filters:



**Tab. 2**

Working pressure bar (psi)	$\Delta p < 140$ (2030)	$140 < \Delta p < 210$ (2030) (3045)	$\Delta p > 210$ (3045)
Contamination class NAS 1638	10	9	8
Contamination class ISO 4406	21/19/16	20/18/15	19/17/14
Achieved with filter $\beta_{10}(c) \geq 75$ according to ISO 16889	-	10 $\mu m$	10 $\mu m$
Achieved with filter $\beta_{25}(c) \geq 200$ according to ISO 16889	25 $\mu m$	-	-

Replaces: 03/02.2012

### DEFINITION OF ROTATION DIRECTION LOOKING AT THE DRIVE SHAFT

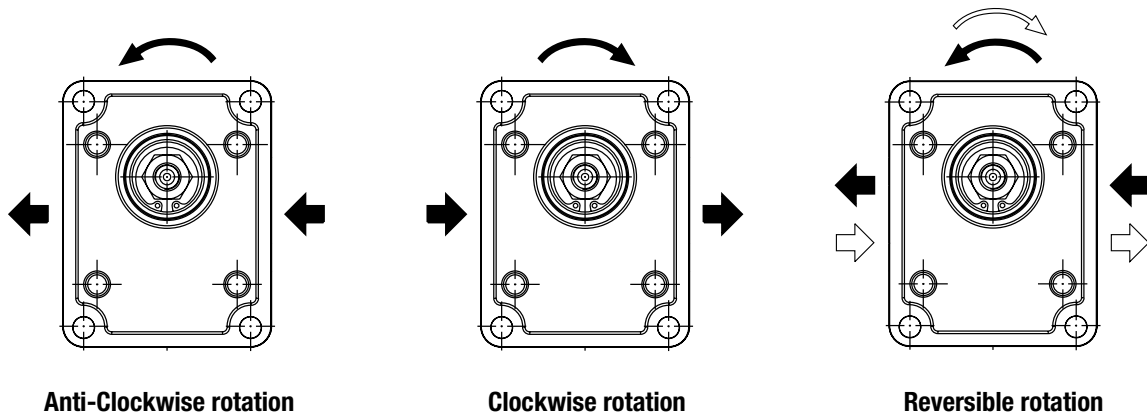

### GENERAL NOTES

Available with different inlet and outlet ports.  
For more information please consult our pre-sales department.

### PRESSURE DEFINITION

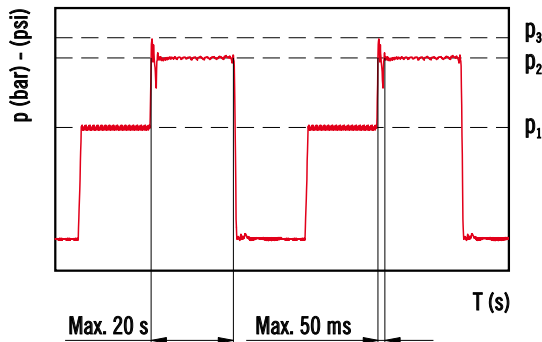

- p<sub>1</sub> Constant operating pressure
- p<sub>2</sub> System pressure (relief valve setting)
- p<sub>3</sub> Peak of pressure

The peak of pressure is the max pressure allowed and it corresponds to the overshoot of the relief valve.

Please note that both relief valve setting and overshoot must be lower than their limits.  
If the relief setting is compliant but the overshoot is higher than the limit, the relief setting must be decreased until the overshoot is compliant to Casappa limit.

For high frequency applications please consult our pre-sales department.

04/10.2020

## FEATURES

Replaces: 01/10.2003

Series	Pump type PLP Motor type PLM	Displacement cm <sup>3</sup> /rev (in <sup>3</sup> /rev)	Max. pressure			Max. speed	Min. speed min <sup>-1</sup>
			P <sub>1</sub>	P <sub>2</sub>	P <sub>3</sub>		
			bar (psi)				
<b>POLARIS 10</b>	<b>PL. 10•1</b>	1,07 (0.07)	260 (3770)	280 (4060)	290 (4205)	4000	650
	<b>PL. 10•1,5</b>	1,60 (0.10)	260 (3770)	280 (4060)	290 (4205)	4000	650
	<b>PL. 10•2</b>	2,13 (0.13)	260 (3770)	280 (4060)	290 (4205)	4000	650
	<b>PL. 10•2,5</b>	2,67 (0.16)	260 (3770)	280 (4060)	290 (4205)	4000	650
	<b>PL. 10•3,15</b>	3,34 (0.20)	260 (3770)	280 (4060)	290 (4205)	4000	650
	<b>PL. 10•4</b>	4,27 (0.26)	250 (3625)	270 (3915)	280 (4060)	4000	650
	<b>PL. 10•5</b>	5,34 (0.33)	250 (3625)	270 (3915)	280 (4060)	4000	650
	<b>PL. 10•5,8</b>	6,20 (0.38)	230 (3335)	250 (3625)	260 (3770)	3500	650
	<b>PL. 10•6,3</b>	6,67 (0.41)	230 (3335)	250 (3625)	260 (3770)	3500	650
	<b>PL. 10•8</b>	8,51 (0.52)	180 (2610)	200 (2900)	210 (3045)	3500	650
<b>PL. 10•10</b>	10,67 (0.65)	140 (2030)	160 (2320)	170 (2465)	3500	650	
<b>POLARIS 20</b>	<b>PL. 20•4</b>	4,95 (0.30)	250 (3625)	280 (4060)	300 (4350)	4000	600
	<b>PL. 20•6,3</b>	6,61 (0.40)	250 (3625)	280 (4060)	300 (4350)	4000	600
	<b>PL. 20•7,2</b>	7,29 (0.44)	250 (3625)	280 (4060)	300 (4350)	4000	600
	<b>PL. 20•8</b>	8,26 (0.50)	250 (3625)	280 (4060)	300 (4350)	3500	600
	<b>PL. 20•9</b>	9,17 (0.56)	250 (3625)	280 (4060)	300 (4350)	3500	600
	<b>PL. 20•10,5</b>	10,9 (0.66)	250 (3625)	280 (4060)	300 (4350)	3500	600
	<b>PL. 20•11,2</b>	11,23 (0.69)	250 (3625)	280 (4060)	300 (4350)	3500	600
	<b>PL. 20•14</b>	14,53 (0.89)	250 (3625)	280 (4060)	300 (4350)	3500	500
	<b>PL. 20•16</b>	16,85 (1.03)	250 (3625)	280 (4060)	300 (4350)	3000	500
	<b>PL. 20•19</b>	19,09 (1.16)	200 (2900)	220 (3190)	3480 (240)	3000	500
	<b>PL. 20•20</b>	21,14 (1.29)	200 (2900)	220 (3190)	3480 (240)	3000	500
	<b>PL. 20•24,5</b>	24,84 (1.52)	170 (2465)	190 (2755)	210 (3045)	2500	500
	<b>PL. 20•25</b>	26,42 (1.61)	170 (2465)	190 (2755)	210 (3045)	2500	500
	<b>PL. 20•27,8</b>	28,21 (1.72)	130 (1885)	150 (2175)	170 (2465)	2000	500
<b>PL. 20•31,5</b>	33,03 (2.01)	130 (1885)	150 (2175)	170 (2465)	2000	500	
<b>POLARIS 30</b>	<b>PL. 30•22</b>	21,99 (1.34)	250 (3625)	270 (3915)	280 (4060)	3000	350
	<b>PL. 30•27</b>	26,70 (1.63)	250 (3625)	270 (3915)	280 (4060)	3000	350
	<b>PL. 30•34</b>	34,55 (2.11)	240 (3480)	260 (3770)	270 (3915)	3000	350
	<b>PL. 30•38</b>	39,27 (2.40)	240 (3480)	260 (3770)	270 (3915)	3000	350
	<b>PL. 30•43</b>	43,98 (2.68)	230 (3335)	250 (3625)	260 (3770)	3000	350
	<b>PL. 30•51</b>	51,83 (3.16)	210 (3045)	230 (3335)	240 (3480)	2500	350
	<b>PL. 30•61</b>	61,26 (3.74)	190 (2755)	210 (3045)	220 (3190)	2500	350
	<b>PL. 30•73</b>	73,82 (4.50)	170 (2465)	190 (2755)	200 (2900)	2500	350
	<b>PL. 30•82</b>	81,68 (4.98)	160 (2320)	170 (2465)	180 (2610)	2200	350
	<b>PL. 30•90</b>	91,10 (5.56)	150 (2175)	160 (2320)	170 (2465)	2200	350

04/10.2020

Pressure values in the table refer to side ports unidirectional pumps and motors.

For reversible pumps and motors, max pressures are 250 bar (3600 psi) excepted those with lower pressure values. ○

For different configurations and working conditions please consult our pre-sales department.

## GENERAL DATA PUMPS AND MOTORS

<b>Q</b>	l/min (US gpm)	Flow
<b>M</b>	Nm (lbf in)	Torque
<b>P</b>	kW (HP)	Power
<b>V</b>	cm <sup>3</sup> /rev (in <sup>3</sup> /rev)	Displacement
<b>n</b>	min <sup>-1</sup>	Speed
<b>Δp</b>	bar (psi)	Pressure

Efficiencies		Pumps	Motors
$\eta_v = \eta_v(V, \Delta p, n)$	Volumetric efficiency	(≈ 0,97)	(≈ 0,96)
$\eta_{hm} = \eta_{hm}(V, \Delta p, n)$	Hydro-mechanical efficiency	(≈ 0,88)	(≈ 0,85)
$\eta_t = \eta_v \cdot \eta_{hm}$	Overall efficiency	(≈ 0,85)	(≈ 0,82)

### DESIGN CALCULATIONS FOR PUMP

$$Q = Q_{\text{theor.}} \cdot \eta_v \quad [\text{l/min}]$$

$$Q_{\text{theor.}} = \frac{V \cdot n}{1000} \quad [\text{l/min}]$$

$$M = \frac{M_{\text{theor.}}}{\eta_{hm}} \quad [\text{Nm}]$$

$$M_{\text{theor.}} = \frac{\Delta p \cdot V}{62,83} \quad [\text{Nm}]$$

$$P_{\text{IN}} = \frac{P_{\text{OUT}}}{\eta_t} \quad [\text{kW}]$$

$$P_{\text{OUT}} = \frac{\Delta p \cdot Q}{600} \quad [\text{kW}]$$

### DESIGN CALCULATIONS FOR MOTOR

$$Q = \frac{Q_{\text{theor.}}}{\eta_v} \quad [\text{l/min}]$$

$$Q_{\text{theor.}} = \frac{V \cdot n}{1000} \quad [\text{l/min}]$$

$$M = M_{\text{theor.}} \cdot \eta_{hm} \quad [\text{Nm}]$$

$$M_{\text{theor.}} = \frac{\Delta p \cdot V}{62,83} \quad [\text{Nm}]$$

$$P_{\text{IN}} = \frac{\Delta p \cdot Q}{600} \quad [\text{kW}]$$

$$P_{\text{OUT}} = P_{\text{IN}} \cdot \eta_t \quad [\text{kW}]$$

03/02.2012

### NOTES

Diagrams providing approximate selection data will be found on subsequent pages.

**PLP 10**

**POLARIS 10 GEAR PUMPS PERFORMANCE CURVES**

**PLP 10**

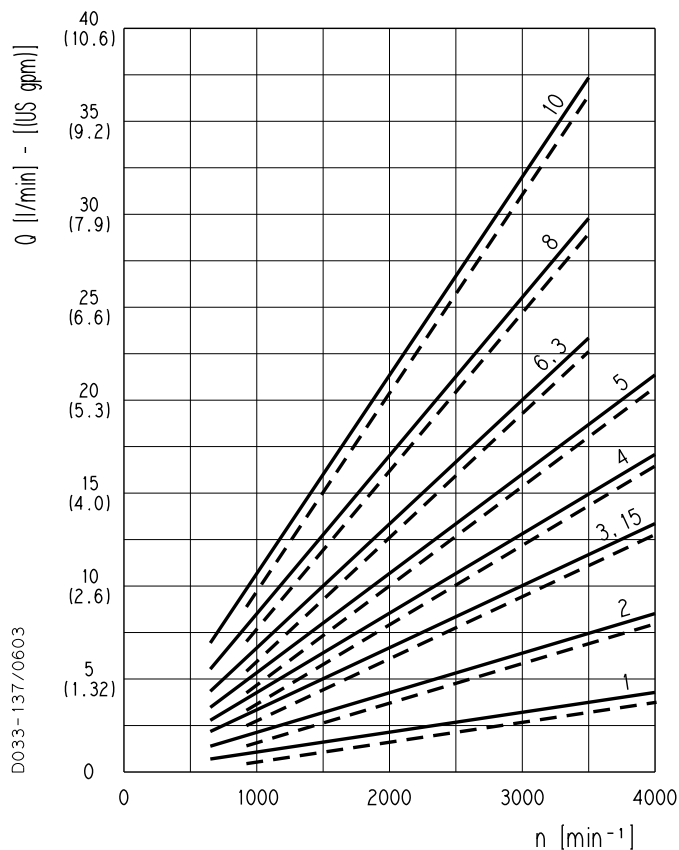

Each curve has been obtained at 50 °C (122 °F), using oil with viscosity 46 cSt (210 SSU) at 40 °C (104 °F) and at these pressures.

<b>PLP 10•1</b>	—	20 bar (290 psi)
	- - -	260 bar (3770 psi)
<b>PLP 10•2</b>	—	20 bar (290 psi)
	- - -	260 bar (3770 psi)
<b>PLP 10•3,15</b>	—	20 bar (290 psi)
	- - -	260 bar (3770 psi)
<b>PLP 10•4</b>	—	20 bar (290 psi)
	- - -	250 bar (3625 psi)
<b>PLP 10•5</b>	—	20 bar (290 psi)
	- - -	250 bar (3625 psi)
<b>PLP 10•6,3</b>	—	20 bar (290 psi)
	- - -	230 bar (3335 psi)
<b>PLP 10•8</b>	—	20 bar (290 psi)
	- - -	180 bar (2610 psi)
<b>PLP 10•10</b>	—	20 bar (290 psi)
	- - -	140 bar (2030 psi)

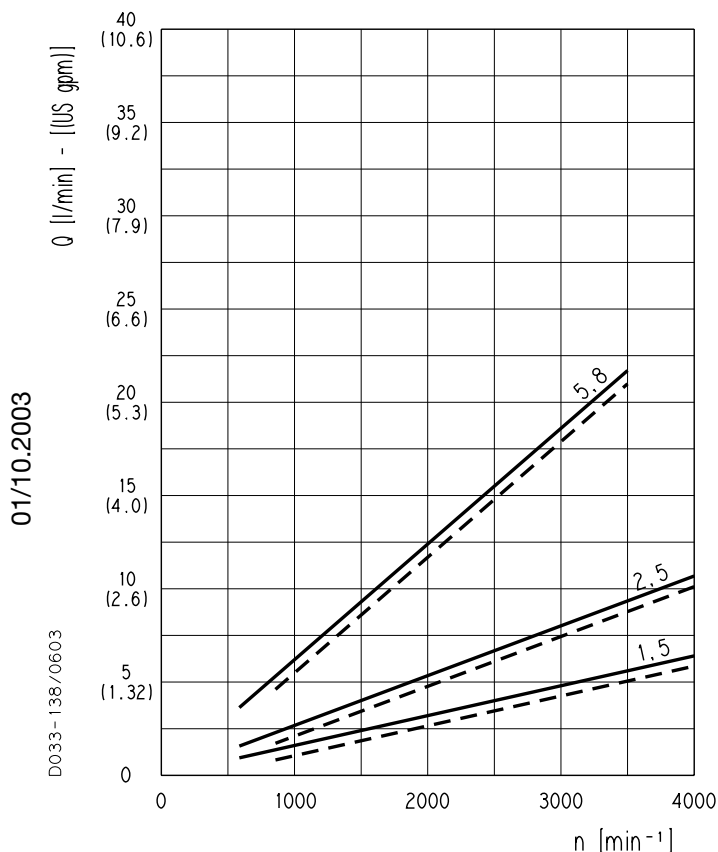

<b>PLP 10•1,5</b>	—	20 bar (290 psi)
	- - -	260 bar (3770 psi)
<b>PLP 10•2,5</b>	—	20 bar (290 psi)
	- - -	260 bar (3770 psi)
<b>PLP 10•5,8</b>	—	20 bar (290 psi)
	- - -	230 bar (3335 psi)

**PLP 10**

**POLARIS 10 GEAR PUMPS PERFORMANCE CURVES**

**PLP 10•1**

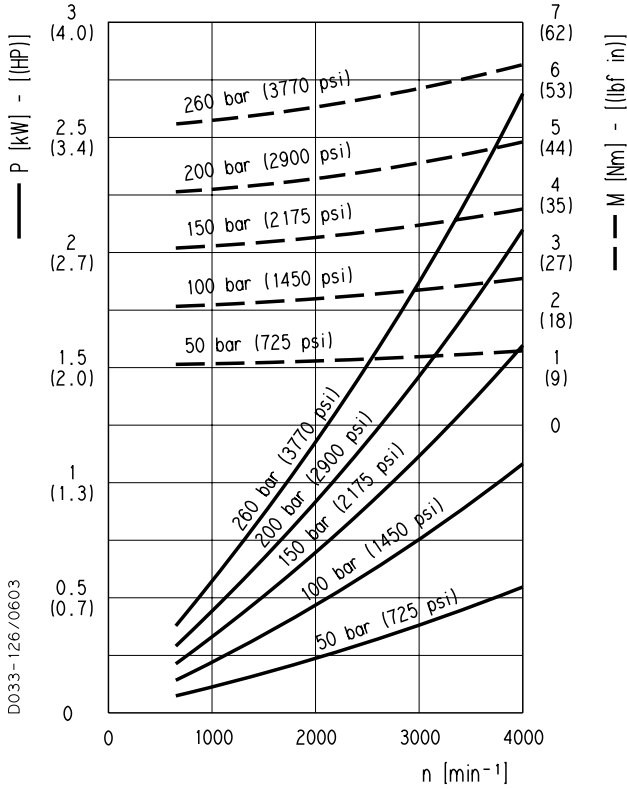

**PLP 10•1,5**

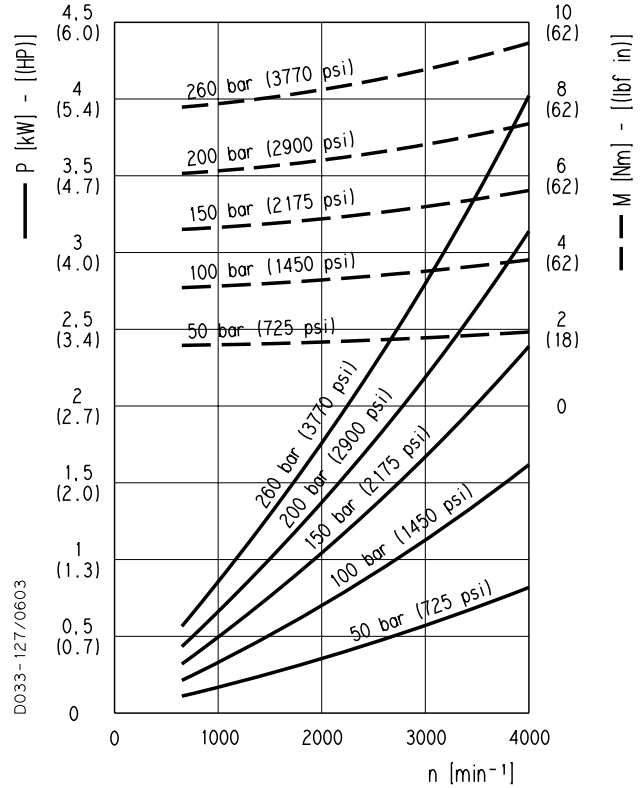

**PLP 10•2**

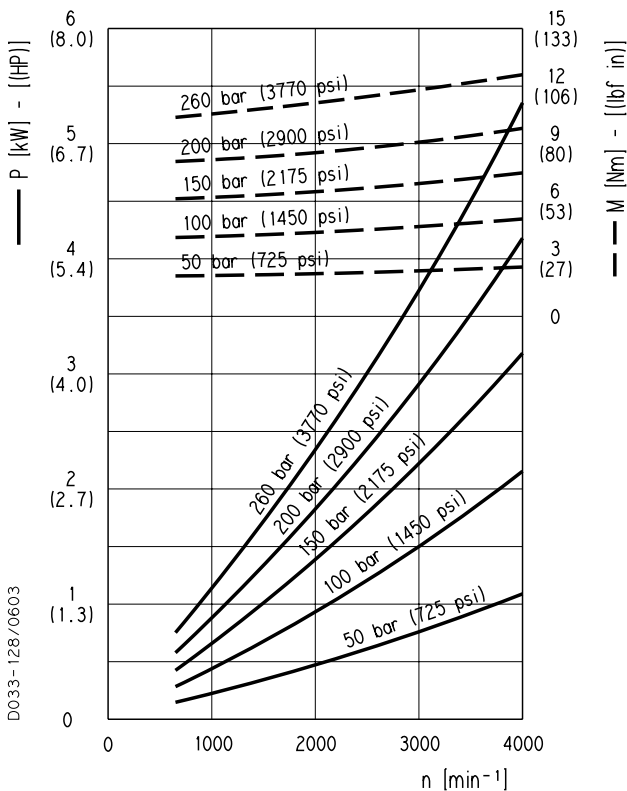

**PLP 10•2,5**

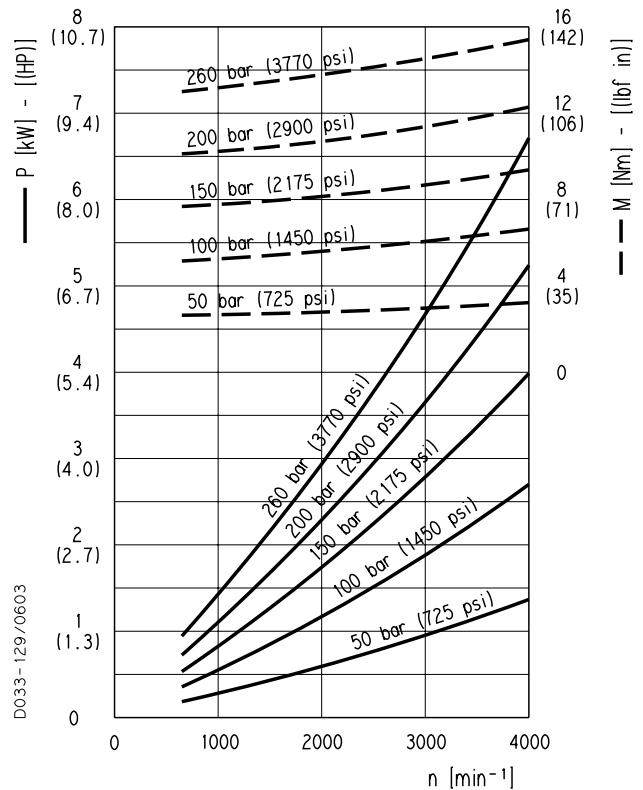

01/10.2003

**PLP 10**

**POLARIS 10 GEAR PUMPS PERFORMANCE CURVES**

**PLP 10•3,15**

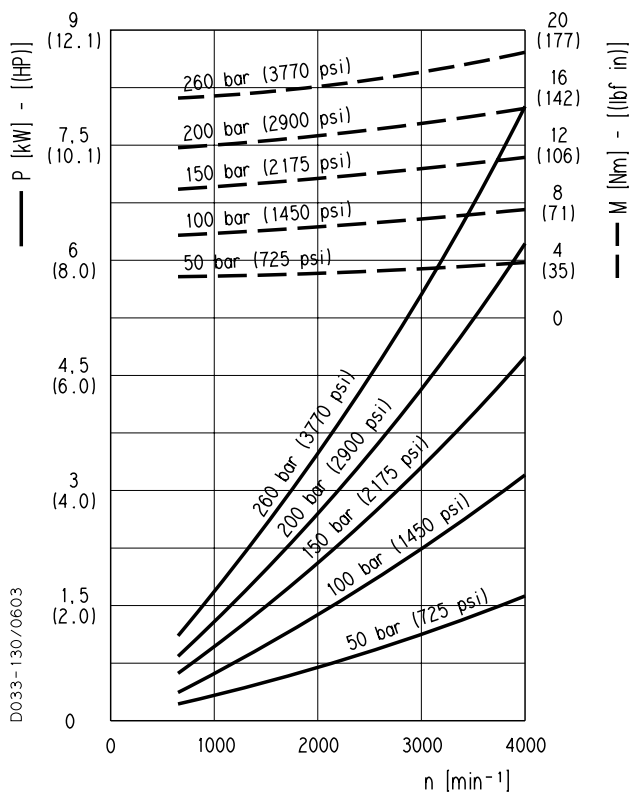

**PLP 10•4**

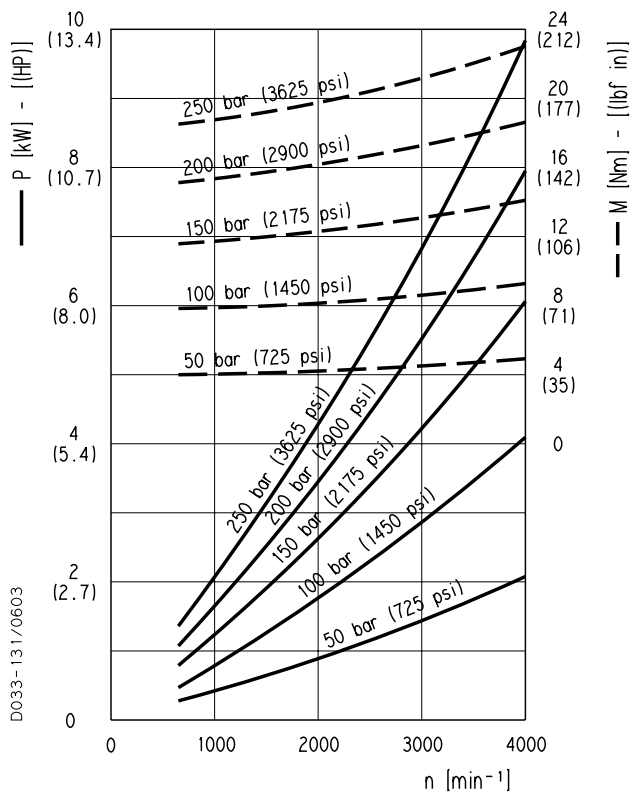

**PLP 10•5**

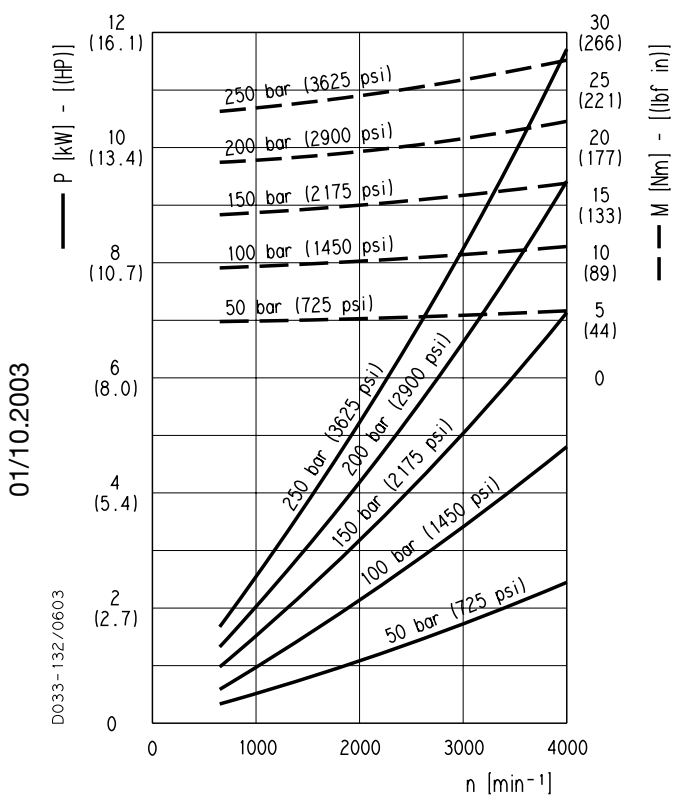

**PLP 10•5,8**

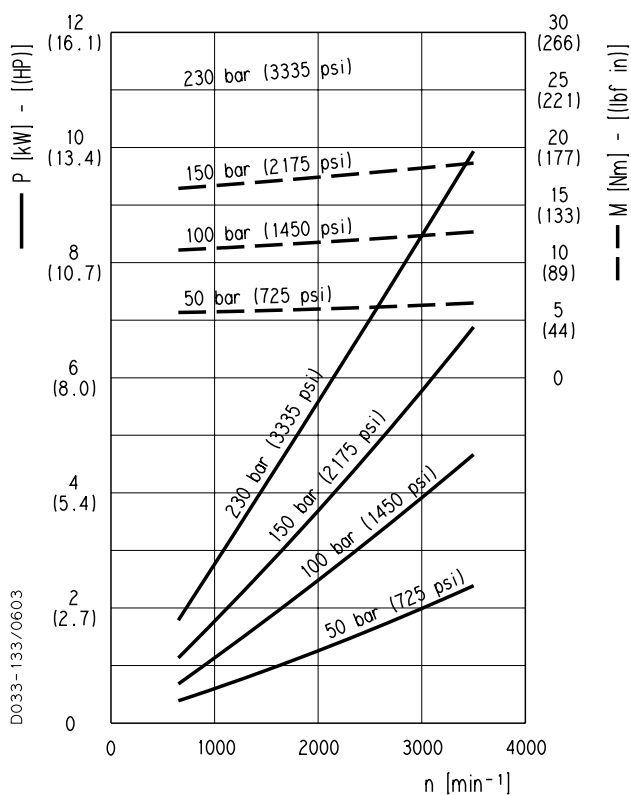

01/10.2003



**PLP 10**

**POLARIS 10 GEAR PUMPS PERFORMANCE CURVES**

**PLP 10•6,3**

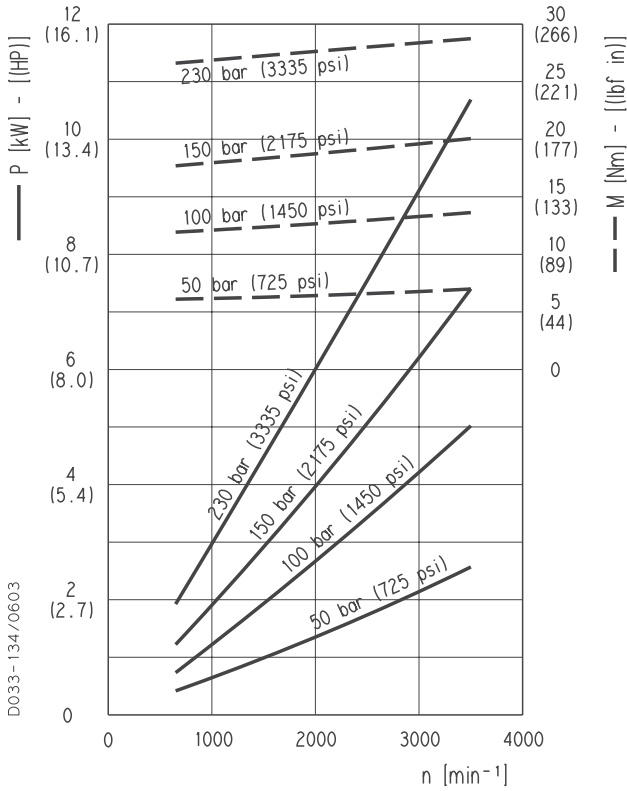

**PLP 10•8**

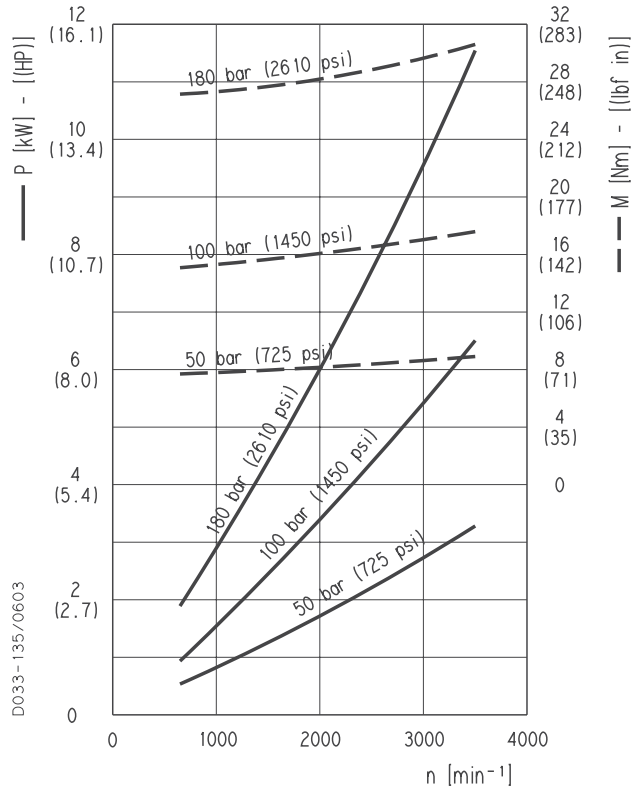

**PLP 10•10**

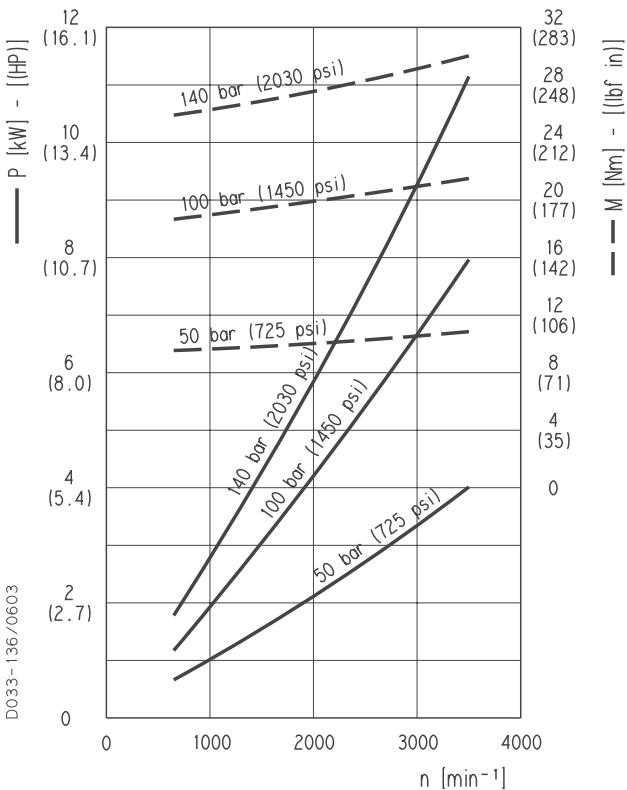

01/10.2003

**PLP 20**

**POLARIS 20 GEAR PUMPS PERFORMANCE CURVES**

**PLP 20**

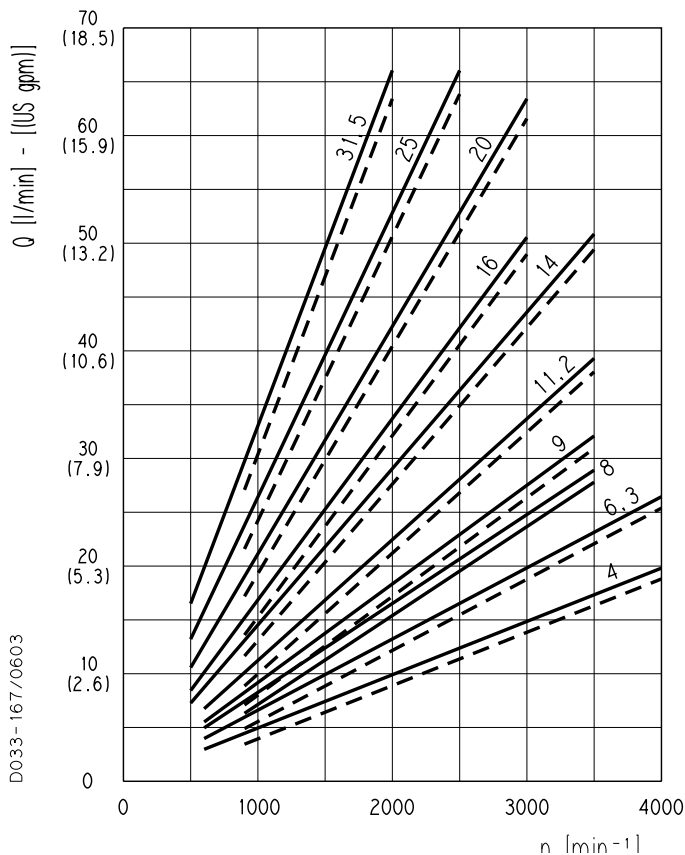

Each curve has been obtained at 50 °C (122 °F), using oil with viscosity 46 cSt (210 SSU) at 40 °C (104 °F) and at these pressures.

<b>PLP 20•4</b>	—	20 bar (290 psi)
	- - -	250 bar (3625 psi)
<b>PLP 20•6,3</b>	—	20 bar (290 psi)
	- - -	250 bar (3625 psi)
<b>PLP 20•8</b>	—	20 bar (290 psi)
	- - -	250 bar (3625 psi)
<b>PLP 20•9</b>	—	20 bar (290 psi)
	- - -	250 bar (3625 psi)
<b>PLP 20•11,2</b>	—	20 bar (290 psi)
	- - -	250 bar (3625 psi)
<b>PLP 20•14</b>	—	20 bar (290 psi)
	- - -	250 bar (3625 psi)
<b>PLP 20•16</b>	—	20 bar (290 psi)
	- - -	250 bar (3625 psi)
<b>PLP 20•20</b>	—	20 bar (290 psi)
	- - -	200 bar (2900 psi)
<b>PLP 20•25</b>	—	20 bar (290 psi)
	- - -	170 bar (2465 psi)
<b>PLP 20•31,5</b>	—	20 bar (290 psi)
	- - -	130 bar (1885 psi)
<b>PLP 20•7,2</b>	—	20 bar (290 psi)
	- - -	250 bar (3625 psi)
<b>PLP 20•10,5</b>	—	20 bar (290 psi)
	- - -	250 bar (3625 psi)
<b>PLP 20•19</b>	—	20 bar (290 psi)
	- - -	200 bar (2900 psi)
<b>PLP 20•24,5</b>	—	20 bar (290 psi)
	- - -	270 bar (2465 psi)
<b>PLP 20•27,8</b>	—	20 bar (290 psi)
	- - -	130 bar (1885 psi)

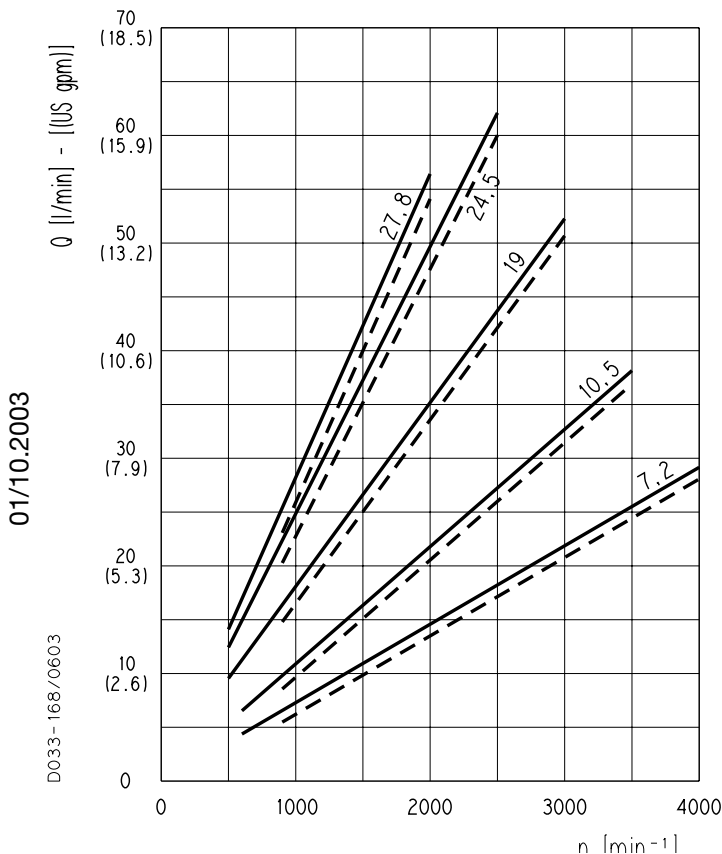

01/10.2003

D033-168/0603

**PLP 20**

**POLARIS 20 GEAR PUMPS PERFORMANCE CURVES**

**PLP 20•4**

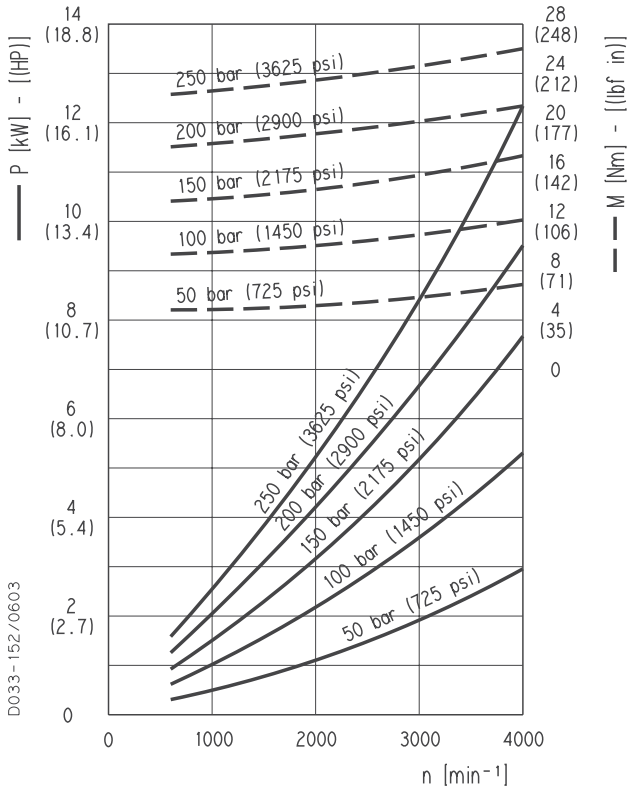

**PLP 20•6,3**

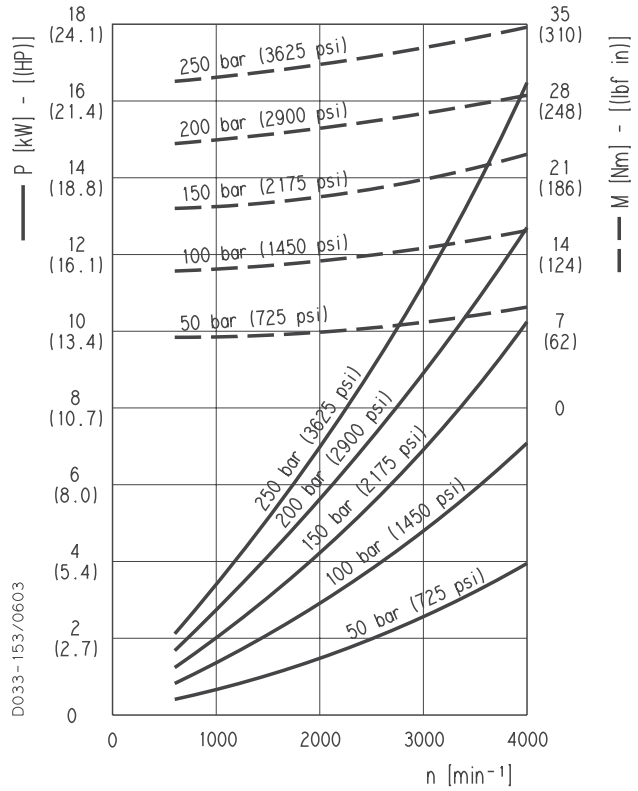

**PLP 20•7,2**

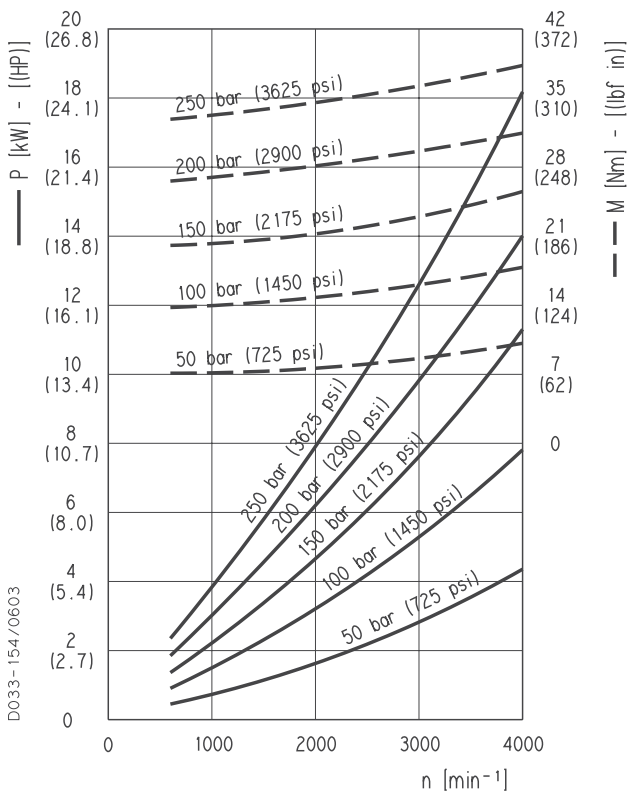

**PLP 20•8**

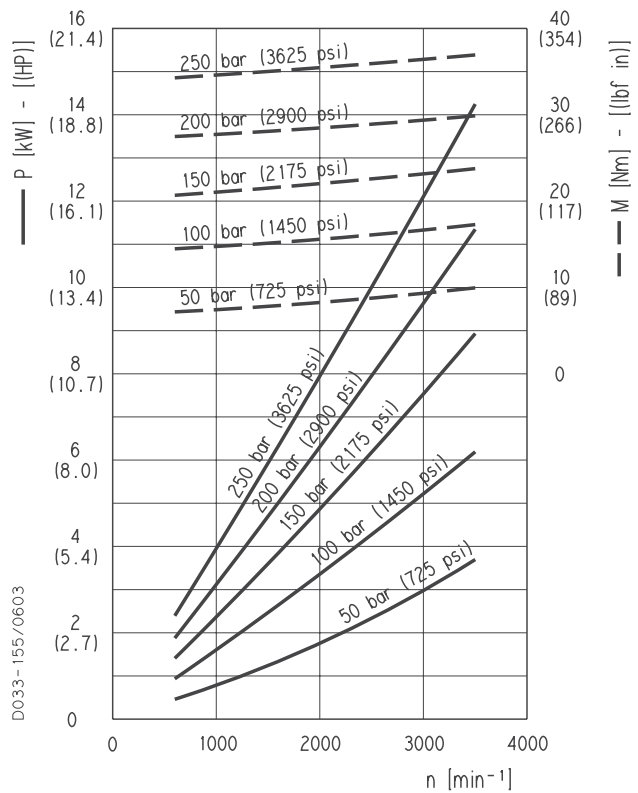

01/10.2003

**PLP 20**

**POLARIS 20 GEAR PUMPS PERFORMANCE CURVES**

**PLP 20•9**

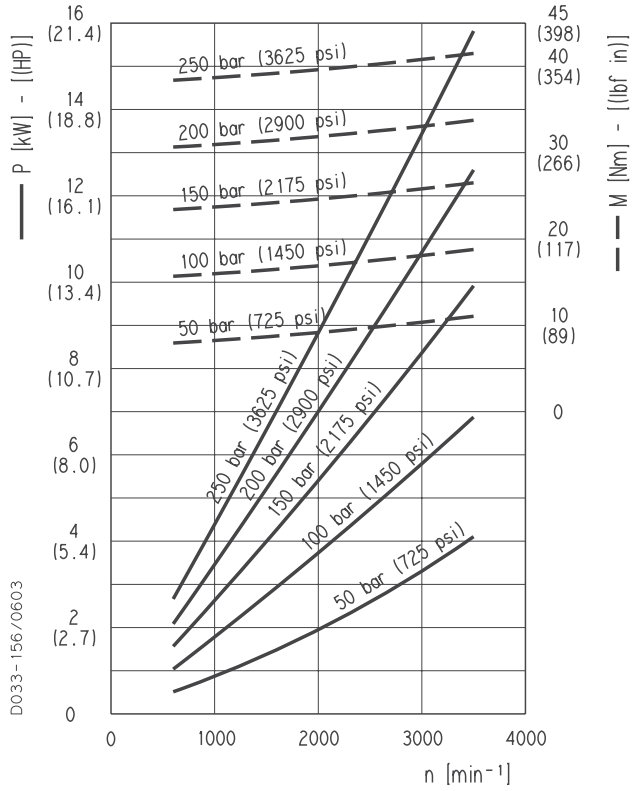

**PLP 20•10,5**

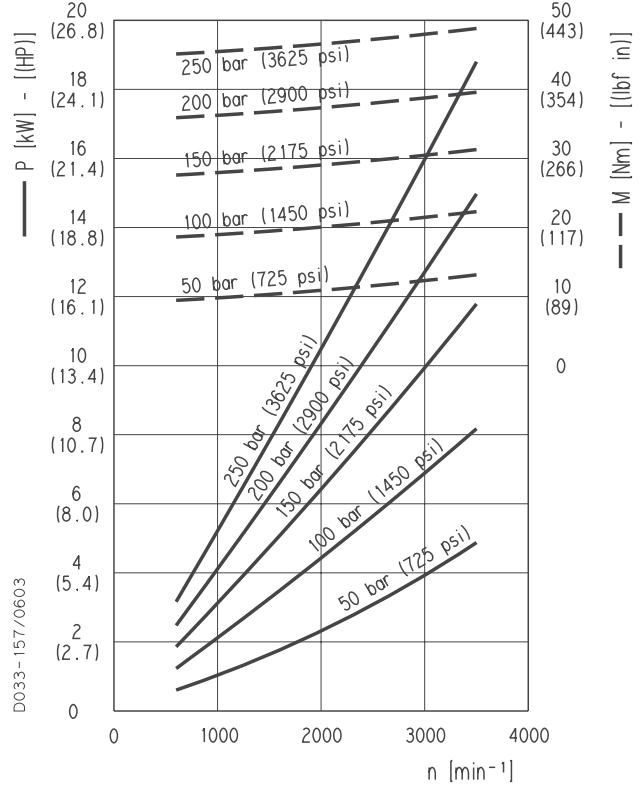

**PLP 20•11,2**

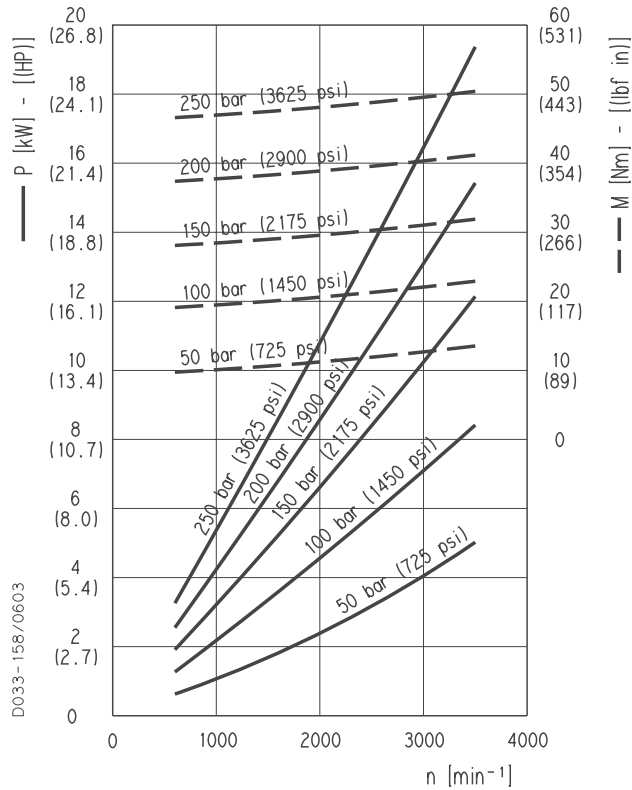

**PLP 20•14**

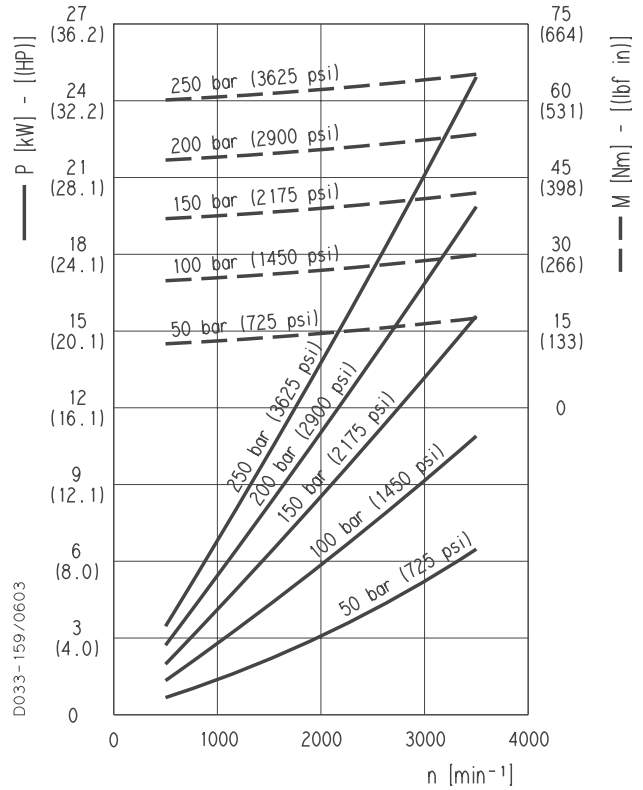

01/10.2003

**PLP 20**

**POLARIS 20 GEAR PUMPS PERFORMANCE CURVES**

**PLP 20•16**

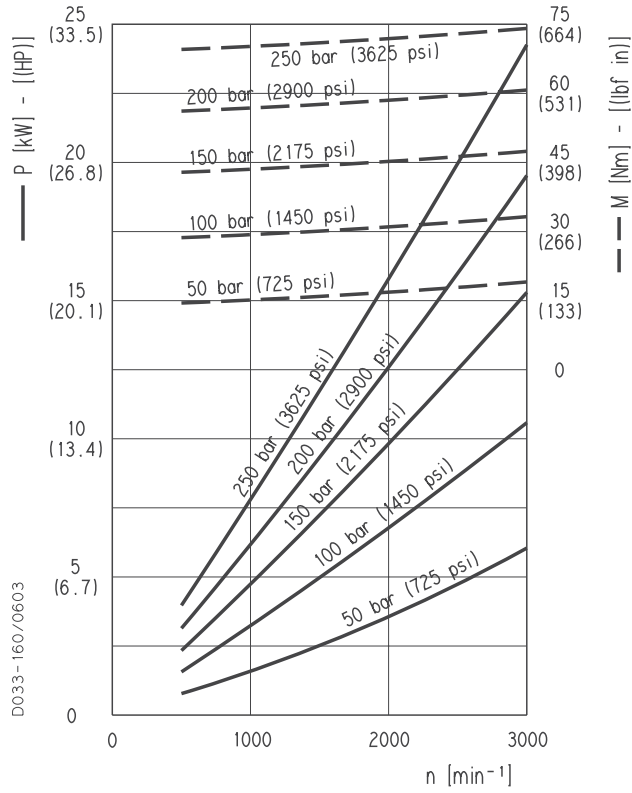

**PLP 20•19**

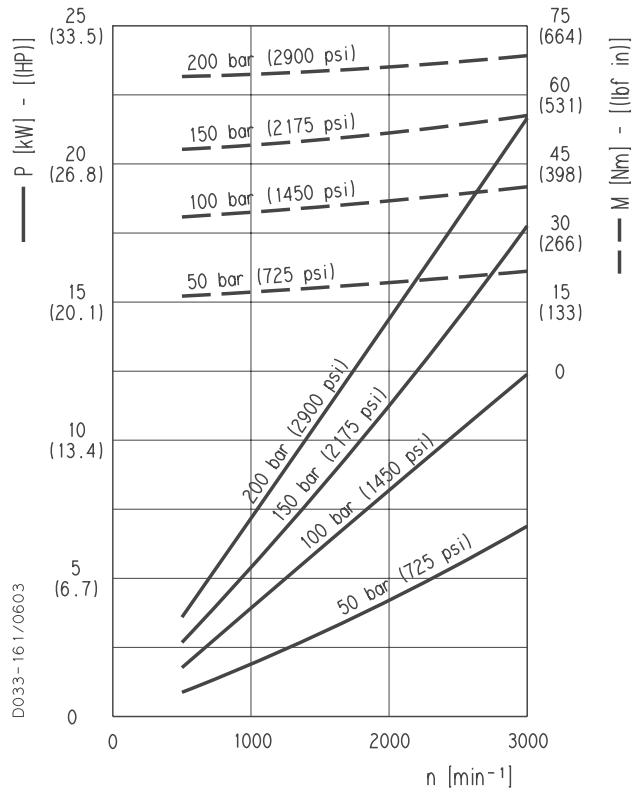

**PLP 20•20**

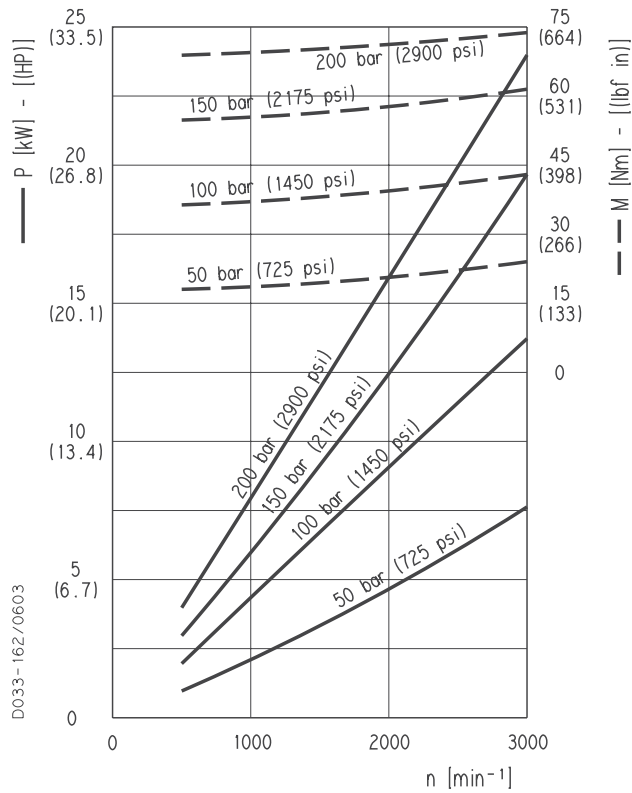

**PLP 20•24,5**

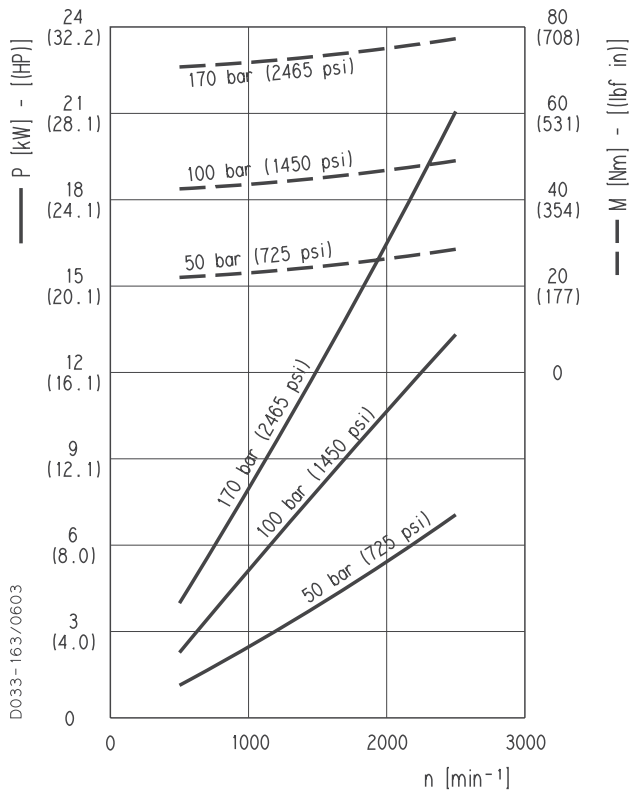

01/10.2003

**PLP 20**

**POLARIS 20 GEAR PUMPS PERFORMANCE CURVES**

**PLP 20•25**

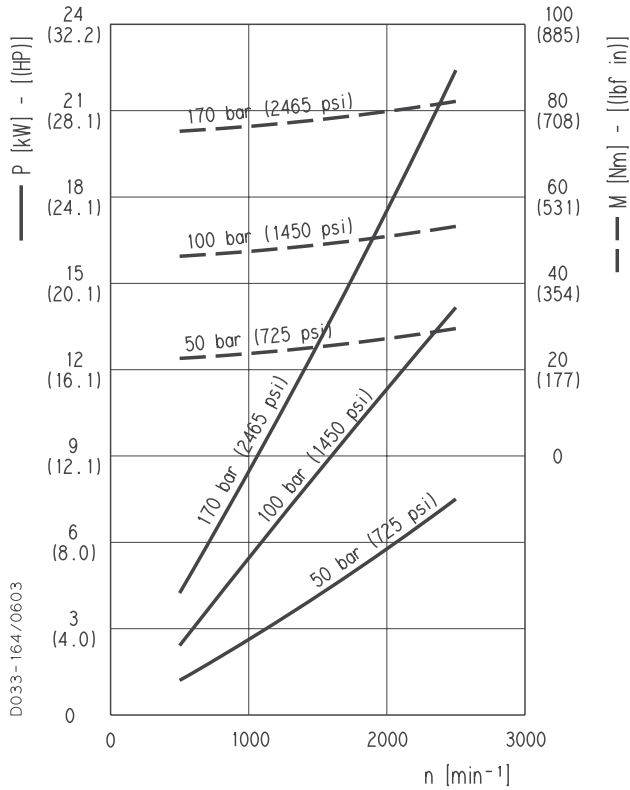

**PLP 20•27,8**

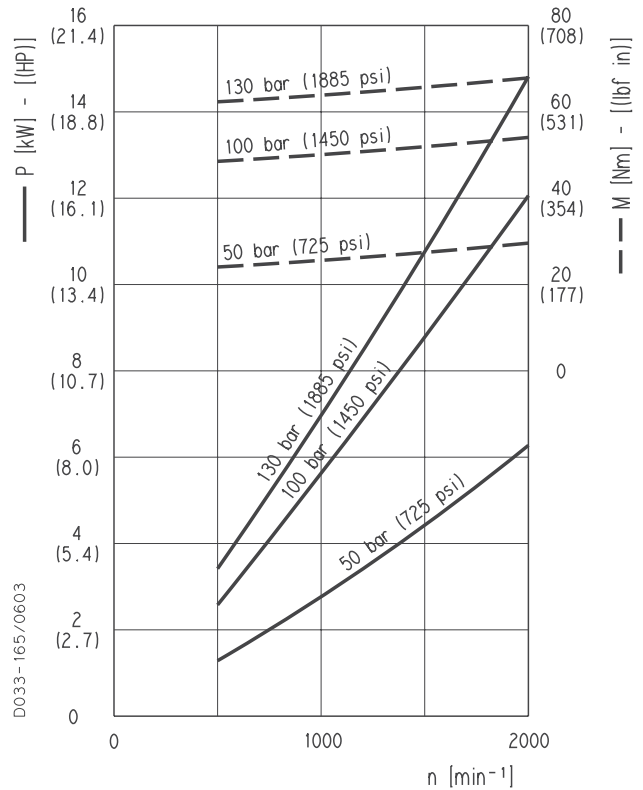

**PLP 20•31,5**

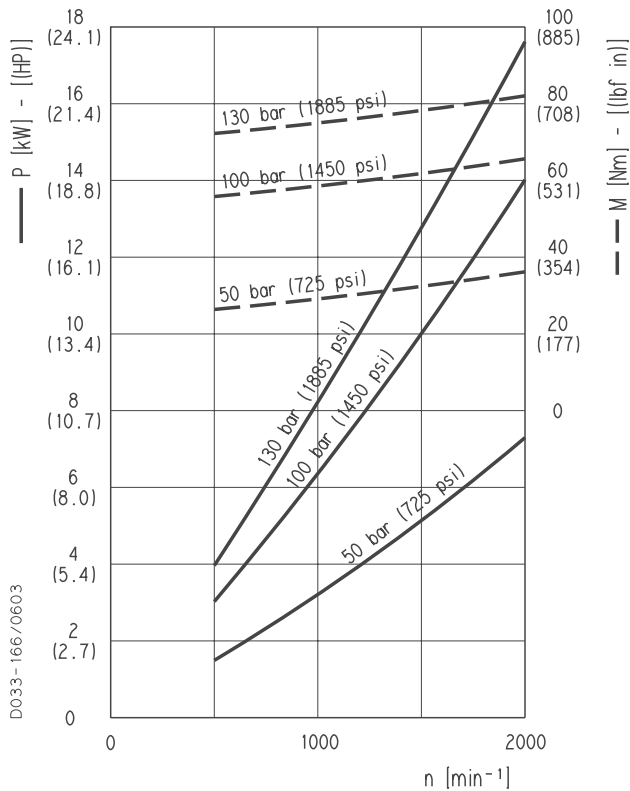

01/10.2003

**PLP 30**

**POLARIS 30 GEAR PUMPS PERFORMANCE CURVES**

Each curve has been obtained at 50 °C (122 °F), using oil with viscosity 46 cSt (210 SSU) at 40 °C (104 °F) and at these pressures.

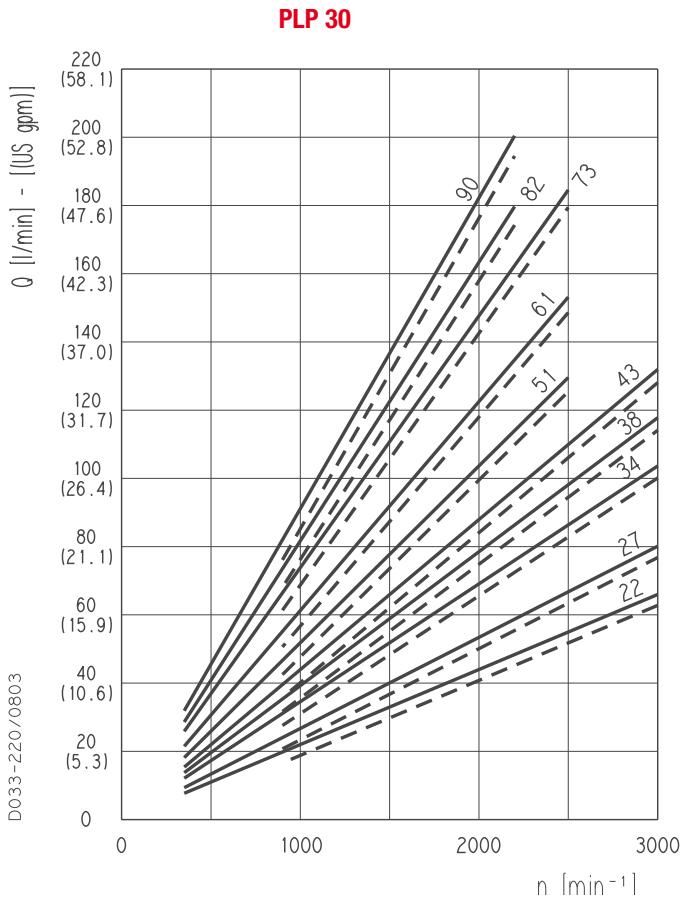

<b>PLP 30•22</b>	————	20 bar (290 psi)
	- - - -	250 bar (3625 psi)
<b>PLP 30•27</b>	————	20 bar (290 psi)
	- - - -	250 bar (3625 psi)
<b>PLP 30•34</b>	————	20 bar (290 psi)
	- - - -	240 bar (3480 psi)
<b>PLP 30•38</b>	————	20 bar (290 psi)
	- - - -	240 bar (3480 psi)
<b>PLP 30•43</b>	————	20 bar (290 psi)
	- - - -	230 bar (3335 psi)
<b>PLP 30•51</b>	————	20 bar (290 psi)
	- - - -	210 bar (3045 psi)
<b>PLP 30•61</b>	————	20 bar (290 psi)
	- - - -	190 bar (2775 psi)
<b>PLP 30•73</b>	————	20 bar (290 psi)
	- - - -	170 bar (2465 psi)
<b>PLP 30•82</b>	————	20 bar (290 psi)
	- - - -	160 bar (2320 psi)
<b>PLP 30•90</b>	————	20 bar (290 psi)
	- - - -	150 bar (2175 psi)

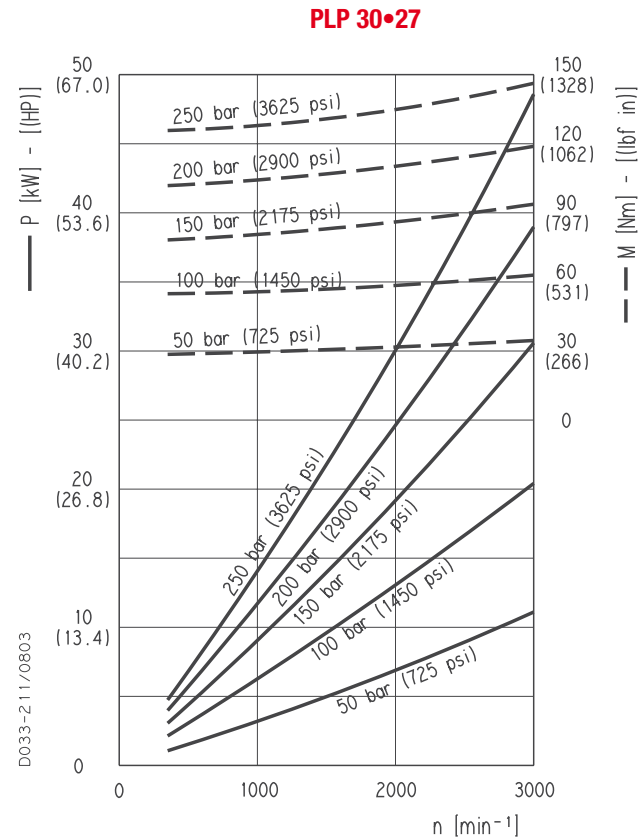
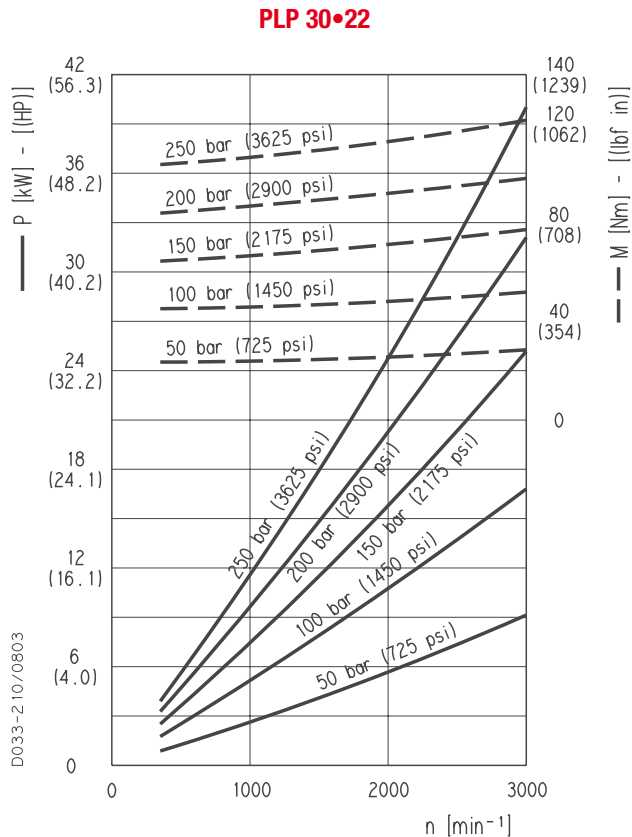

01/10.2003

**PLP 30**

**POLARIS 30 GEAR PUMPS PERFORMANCE CURVES**

**PLP 30•34**

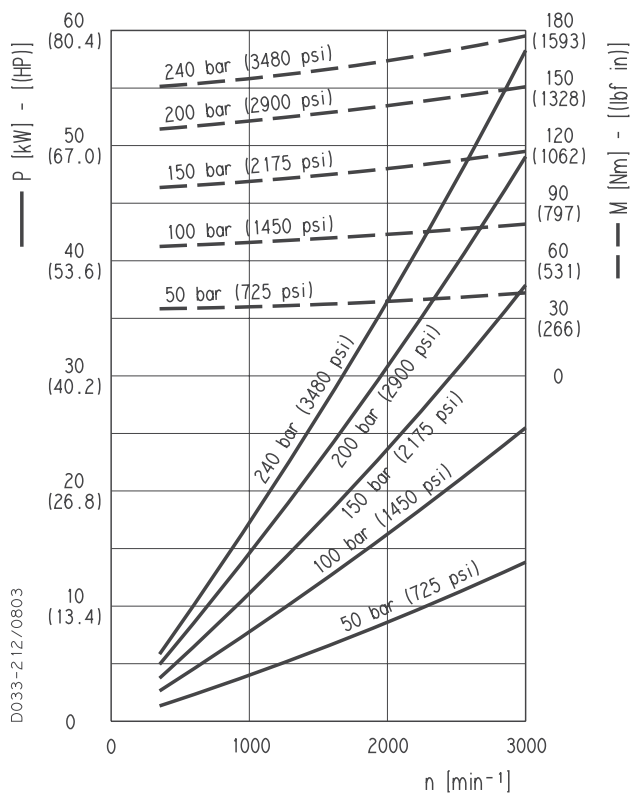

**PLP 30•38**

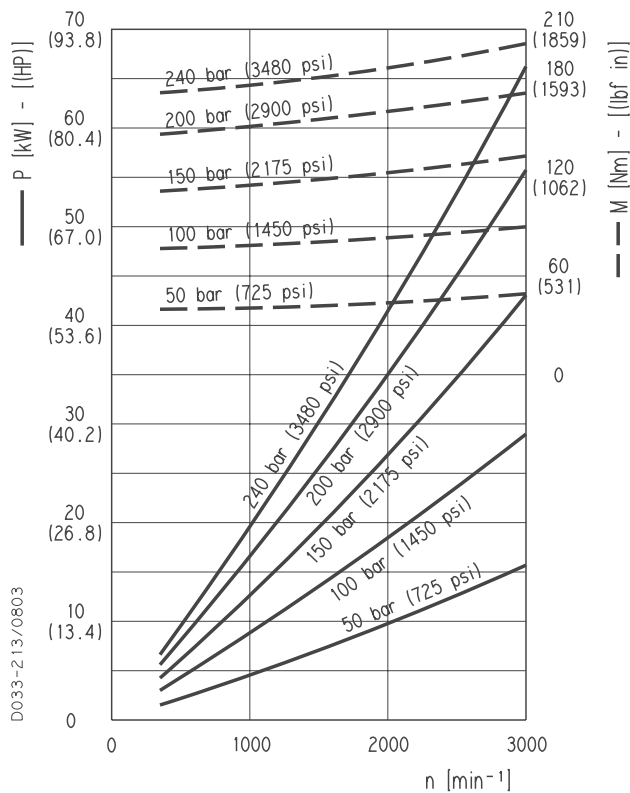

**PLP 30•43**

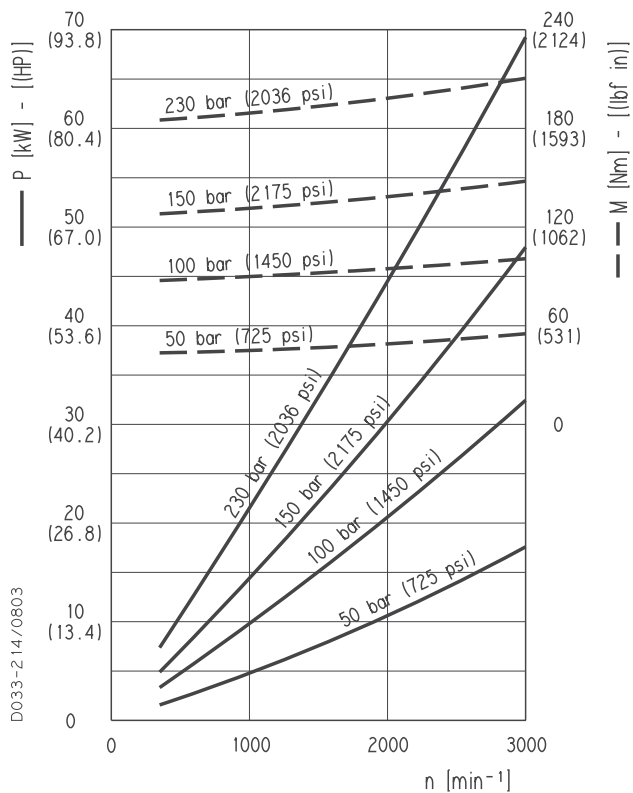

**PLP 30•51**

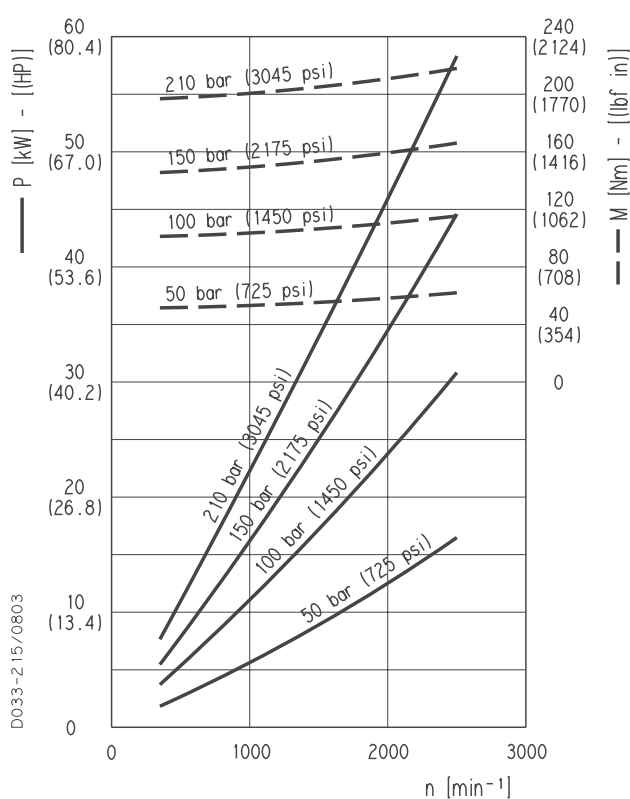

01/10.2003



**PLP 30**

**POLARIS 30 GEAR PUMPS PERFORMANCE CURVES**

**PLP 30•61**

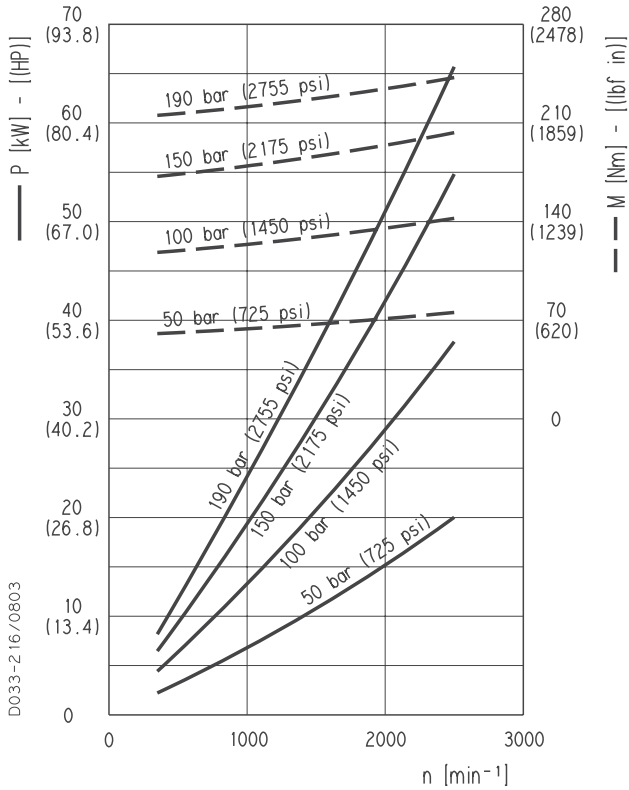

**PLP 30•73**

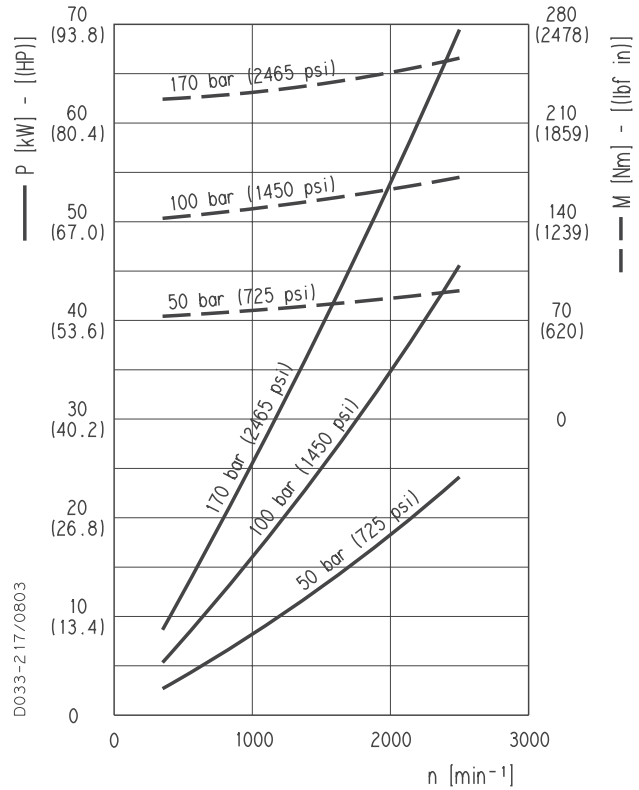

**PLP 30•82**

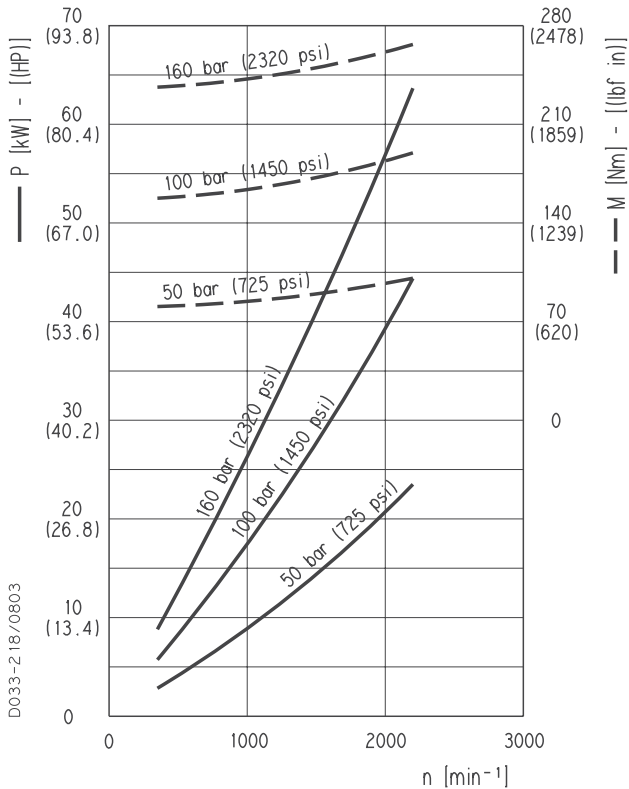

**PLP 30•90**

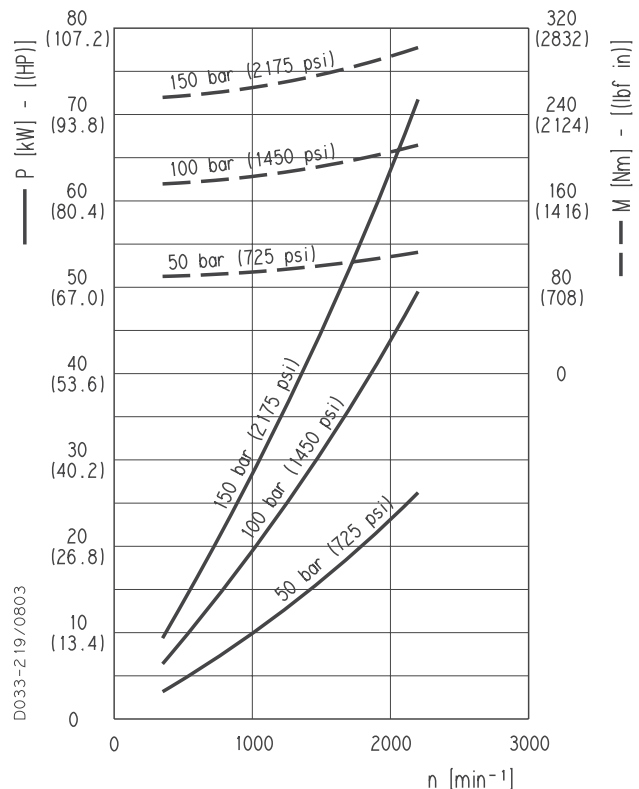

01/10.2003

**PLM 10**

**POLARIS 10 GEAR MOTORS PERFORMANCE CURVES**

**PLM 10**

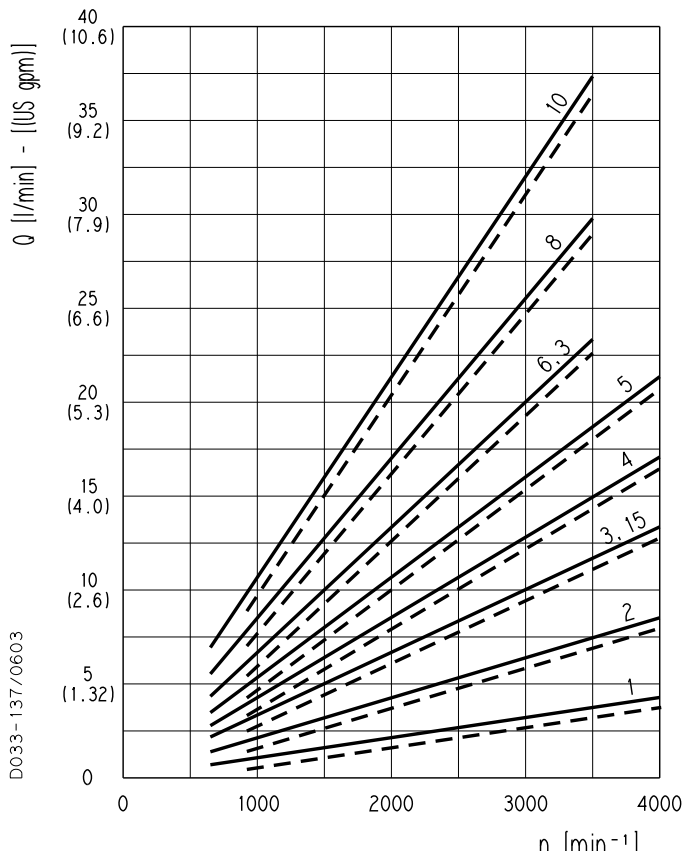

Each curve has been obtained at 50 °C (122 °F), using oil with viscosity 46 cSt (210 SSU) at 40 °C (104 °F) and at these pressures.

<b>PLM 10•1</b>	————	20 bar (290 psi)
	- - - -	260 bar (3770 psi)
<b>PLM 10•2</b>	————	20 bar (290 psi)
	- - - -	260 bar (3770 psi)
<b>PLM 10•3,15</b>	————	20 bar (290 psi)
	- - - -	260 bar (3770 psi)
<b>PLM 10•4</b>	————	20 bar (290 psi)
	- - - -	250 bar (3625 psi)
<b>PLM 10•5</b>	————	20 bar (290 psi)
	- - - -	250 bar (3625 psi)
<b>PLM 10•6,3</b>	————	20 bar (290 psi)
	- - - -	230 bar (3335 psi)
<b>PLM 10•8</b>	————	20 bar (290 psi)
	- - - -	180 bar (2610 psi)
<b>PLM 10•10</b>	————	20 bar (290 psi)
	- - - -	140 bar (2030 psi)

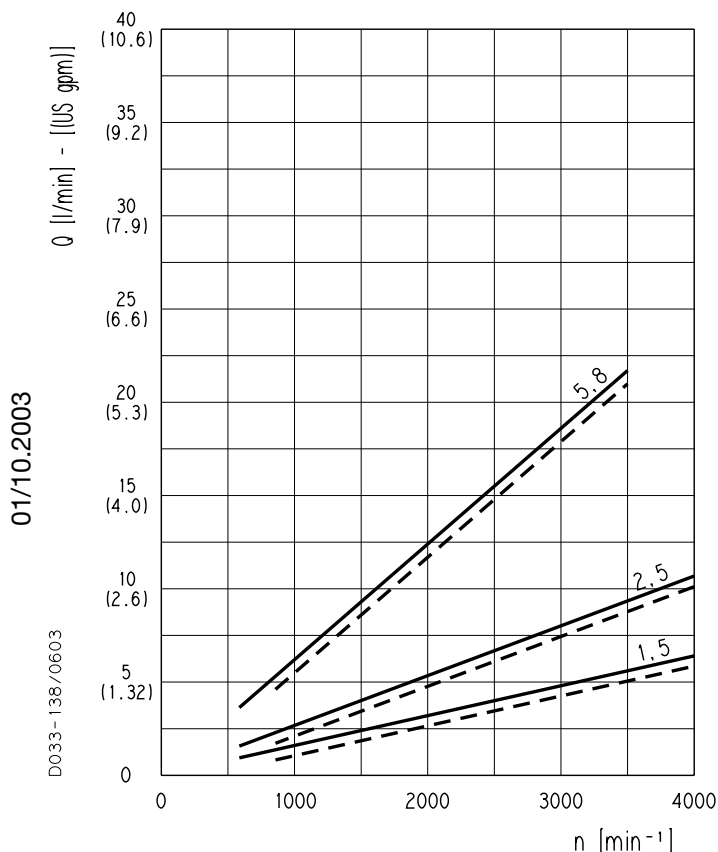

<b>PLM 10•1,5</b>	————	20 bar (290 psi)
	- - - -	260 bar (3770 psi)
<b>PLM 10•2,5</b>	————	20 bar (290 psi)
	- - - -	260 bar (3770 psi)
<b>PLM 10•5,8</b>	————	20 bar (290 psi)
	- - - -	230 bar (3335 psi)

**PLM 10**

**POLARIS 10 GEAR MOTORS PERFORMANCE CURVES**

**PLM 10•1**

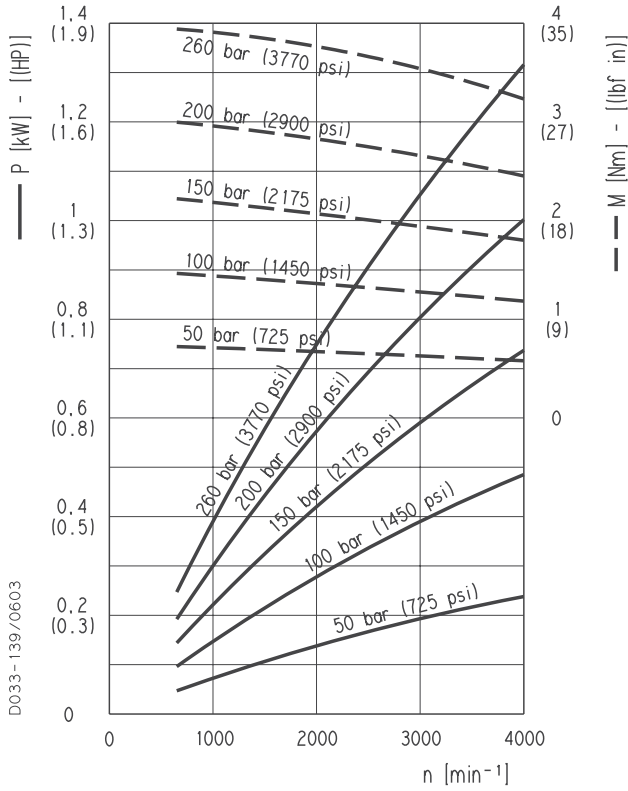

**PLM 10•1,5**

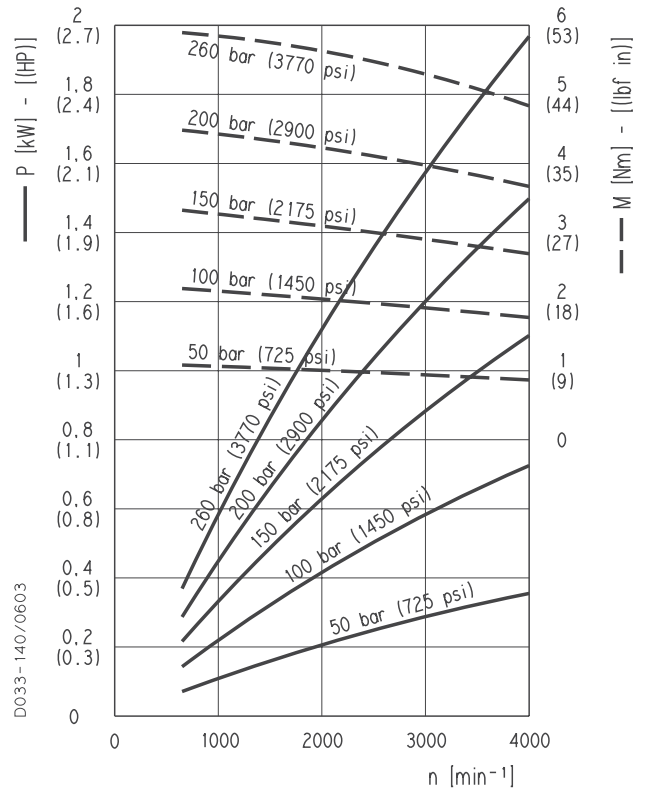

**PLM 10•2**

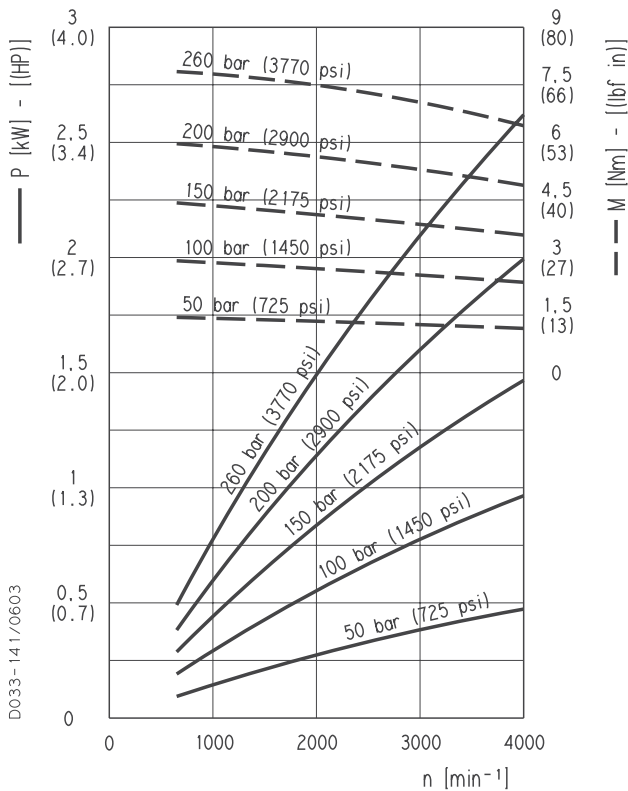

**PLM 10•2,5**

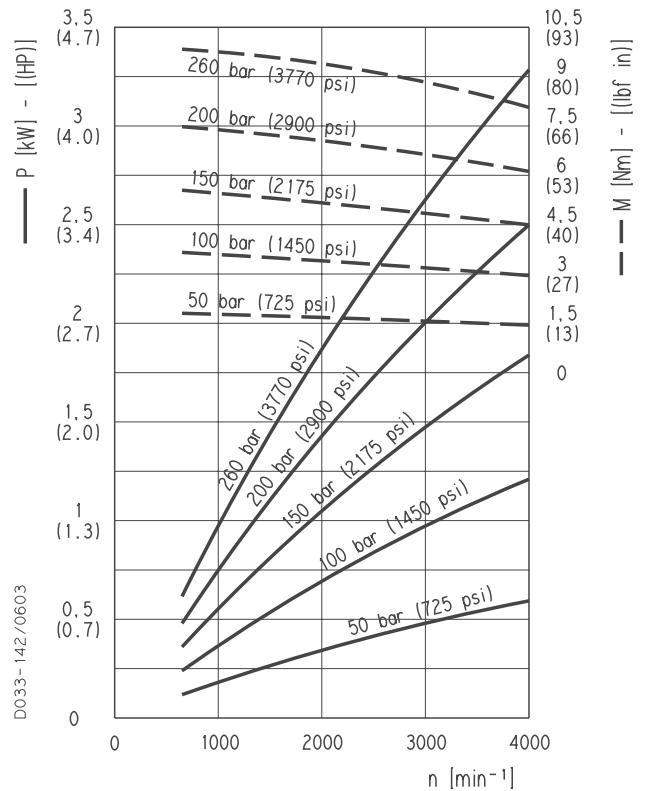

01/10.2003

**PLM 10**

**POLARIS 10 GEAR MOTORS PERFORMANCE CURVES**

**PLM 10•3,15**

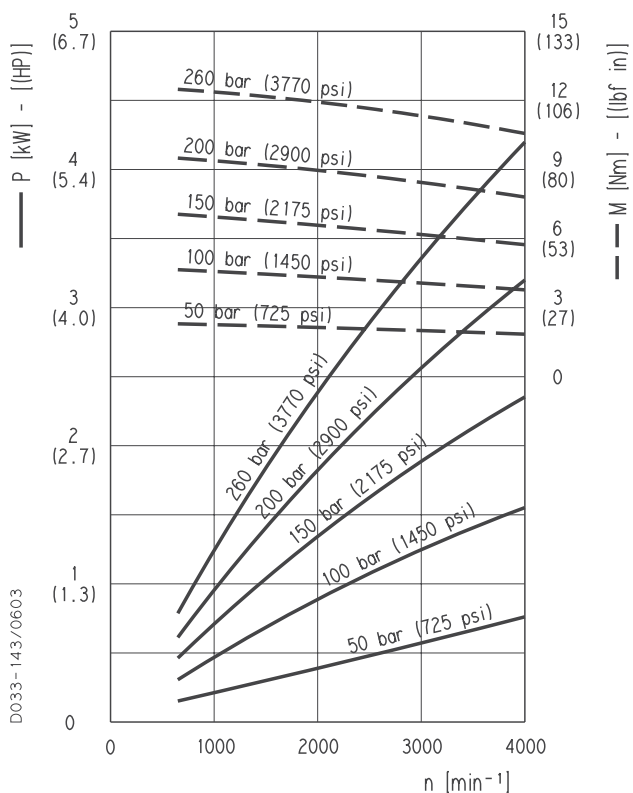

**PLM 10•4**

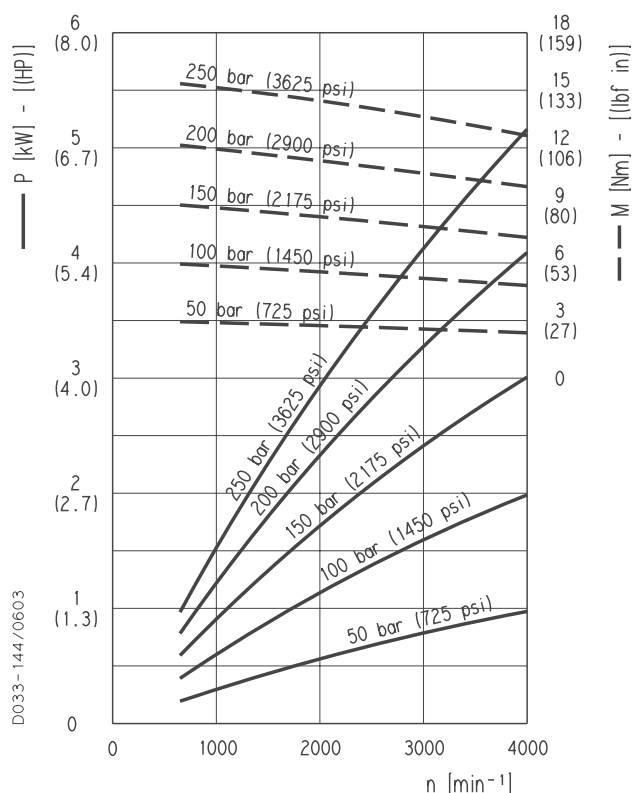

**PLM 10•5**

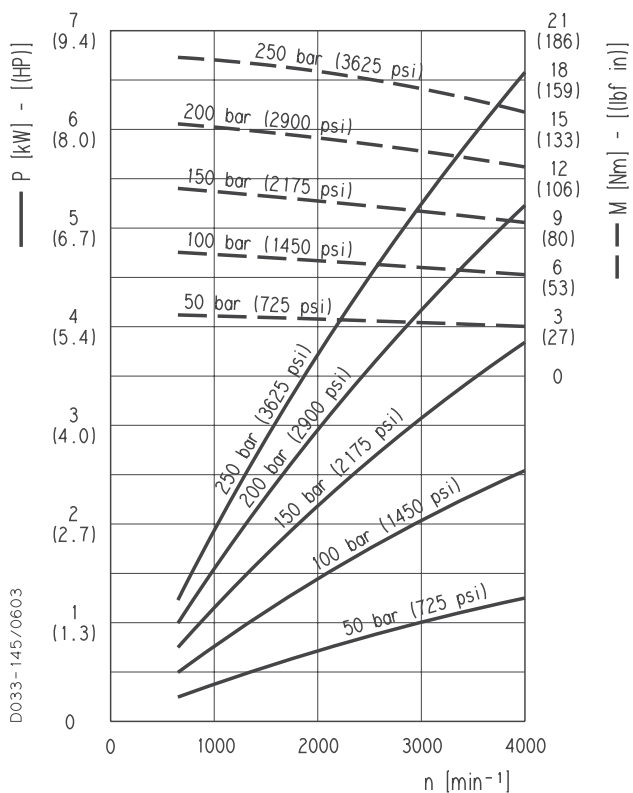

**PLM 10•5,8**

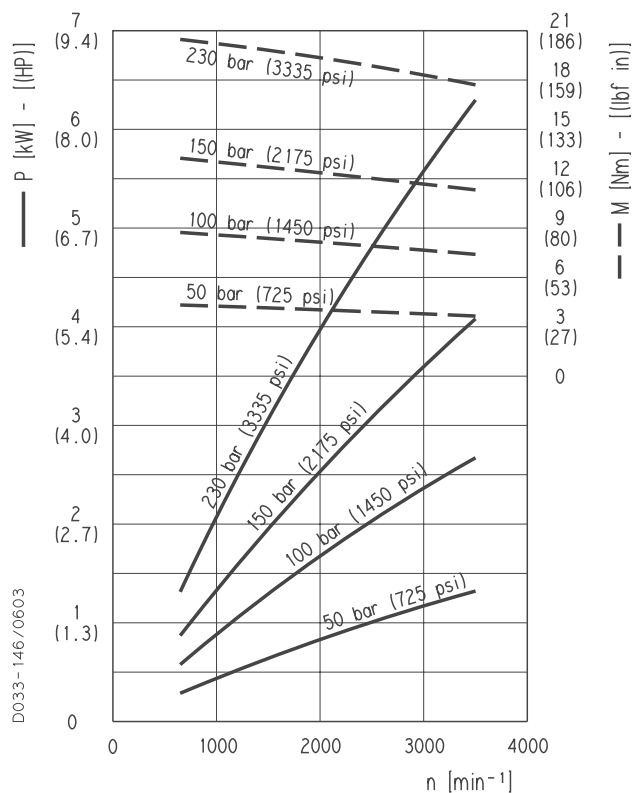

01/10.2003

**PLM 10**

**POLARIS 10 GEAR MOTORS PERFORMANCE CURVES**

**PLM 10•6,3**

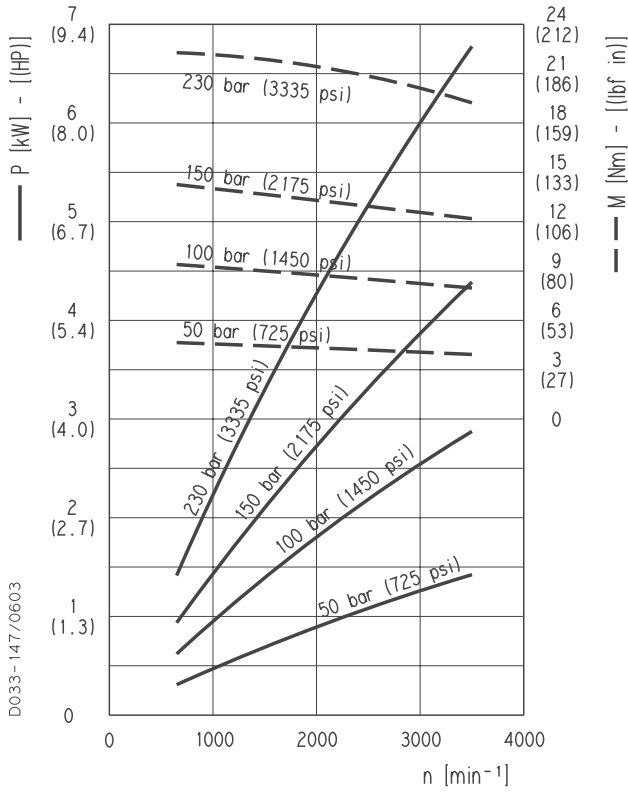

**PLM 10•8**

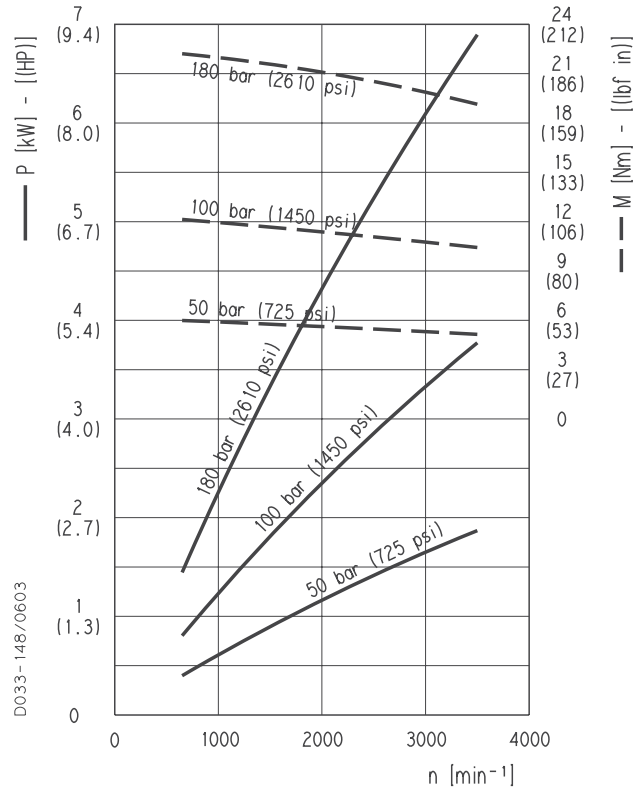

**PLM 10•10**

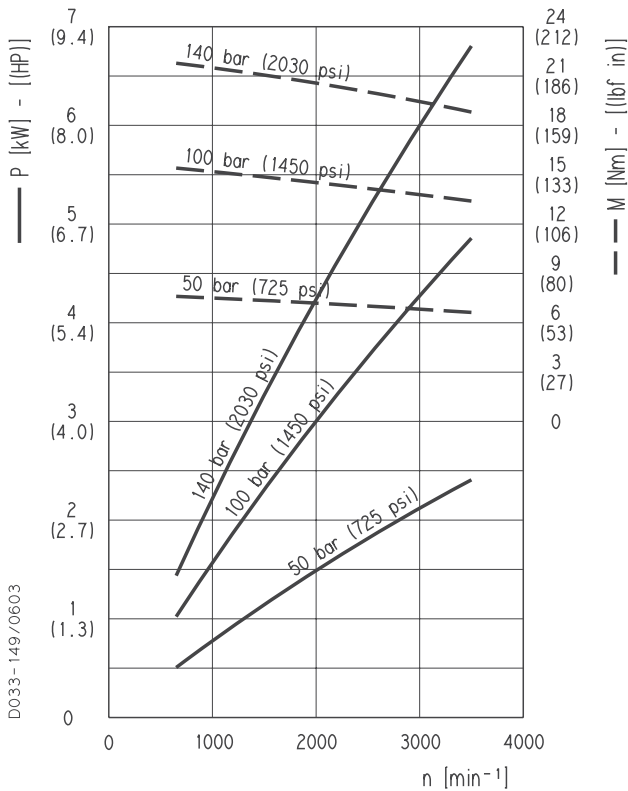

01/10.2003

**PLM 20**

**POLARIS 20 GEAR MOTORS PERFORMANCE CURVES**

**PLM 20**

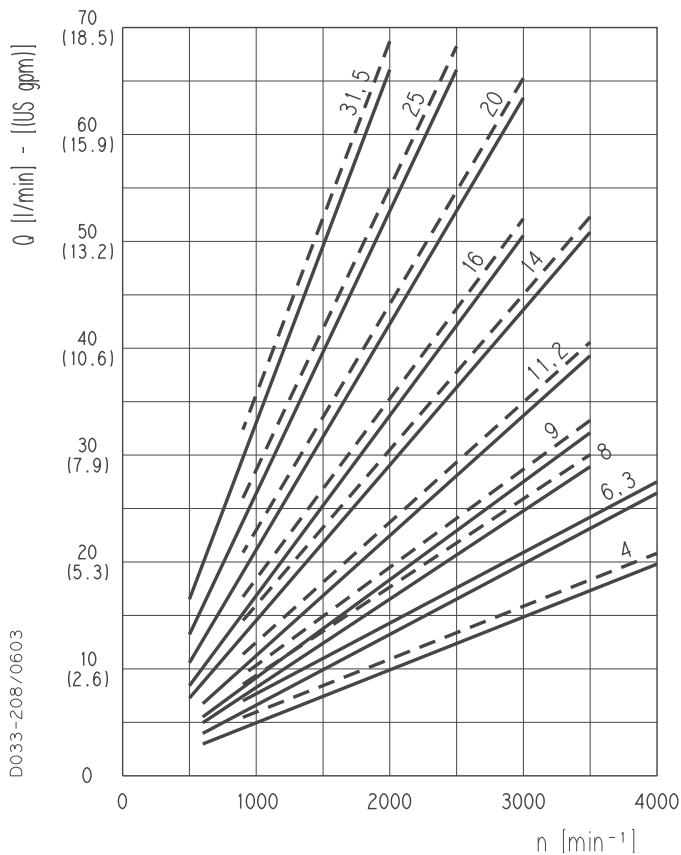

Each curve has been obtained at 50 °C (122 °F), using oil with viscosity 46 cSt (210 SSU) at 40 °C (104 °F) and at these pressures.

<b>PLM 20•4</b>	—	20 bar (290 psi)
	- - -	250 bar (3625 psi)
<b>PLM 20•6,3</b>	—	20 bar (290 psi)
	- - -	250 bar (3625 psi)
<b>PLM 20•8</b>	—	20 bar (290 psi)
	- - -	250 bar (3625 psi)
<b>PLM 20•9</b>	—	20 bar (290 psi)
	- - -	250 bar (3625 psi)
<b>PLM 20•11,2</b>	—	20 bar (290 psi)
	- - -	250 bar (3625 psi)
<b>PLM 20•14</b>	—	20 bar (290 psi)
	- - -	250 bar (3625 psi)
<b>PLM 20•16</b>	—	20 bar (290 psi)
	- - -	250 bar (3625 psi)
<b>PLM 20•20</b>	—	20 bar (290 psi)
	- - -	200 bar (2900 psi)
<b>PLM 20•25</b>	—	20 bar (290 psi)
	- - -	170 bar (2465 psi)
<b>PLM 20•31,5</b>	—	20 bar (290 psi)
	- - -	130 bar (1885 psi)
<b>PLM 20•7,2</b>	—	20 bar (290 psi)
	- - -	250 bar (3625 psi)
<b>PLM 20•10,5</b>	—	20 bar (290 psi)
	- - -	250 bar (3625 psi)
<b>PLM 20•19</b>	—	20 bar (290 psi)
	- - -	200 bar (2900 psi)
<b>PLM 20•24,5</b>	—	20 bar (290 psi)
	- - -	270 bar (2465 psi)
<b>PLM 20•27,8</b>	—	20 bar (290 psi)
	- - -	130 bar (1885 psi)

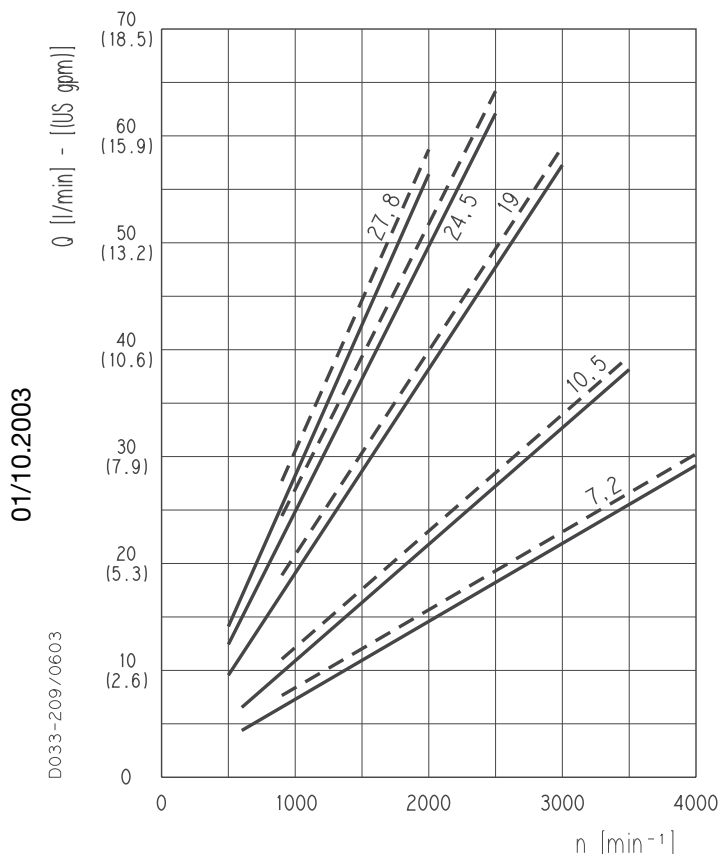

01/10.2003

**PLM 20**

**POLARIS 20 GEAR MOTORS PERFORMANCE CURVES**

**PLM 20•4**

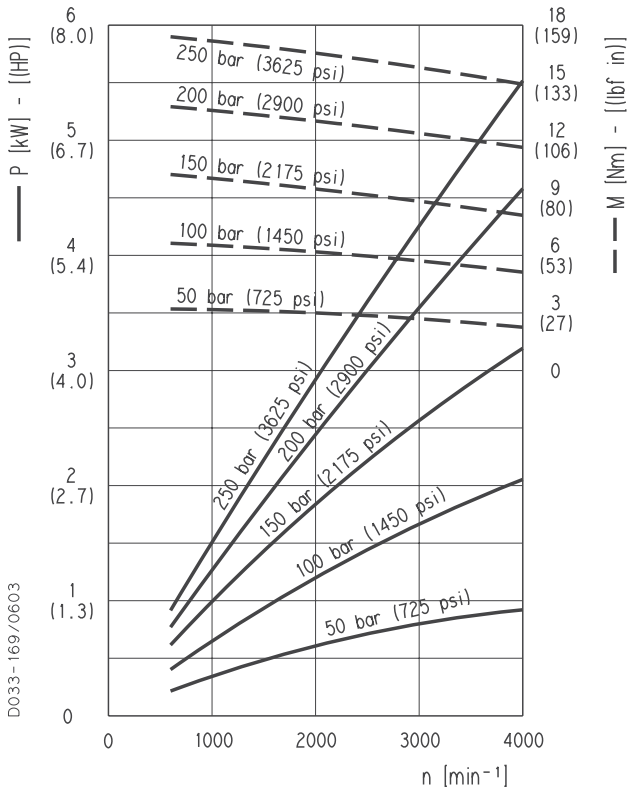

**PLM 20•6,3**

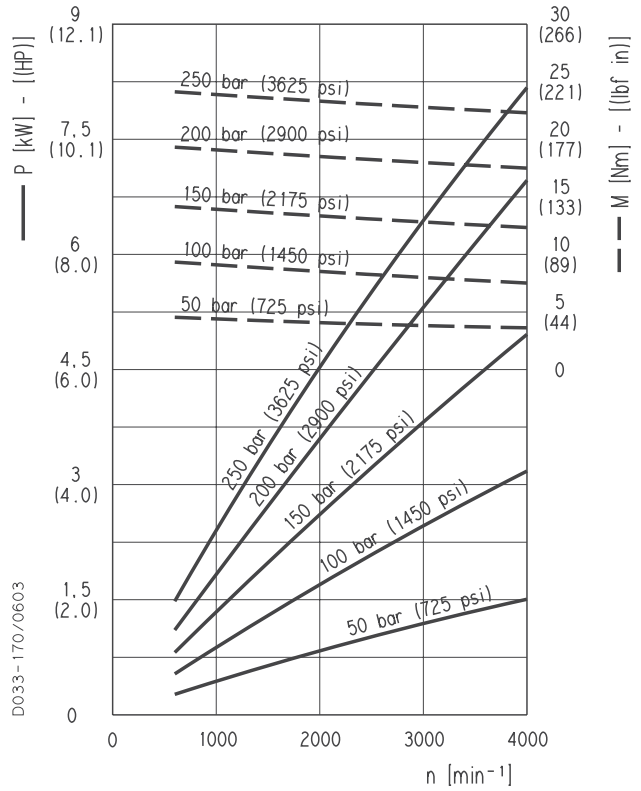

**PLM 20•7,2**

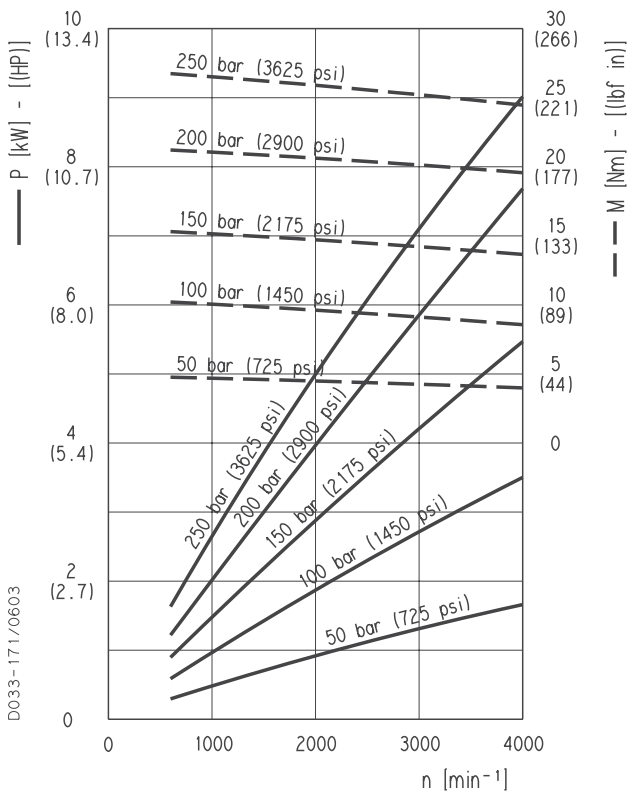

**PLM 20•8**

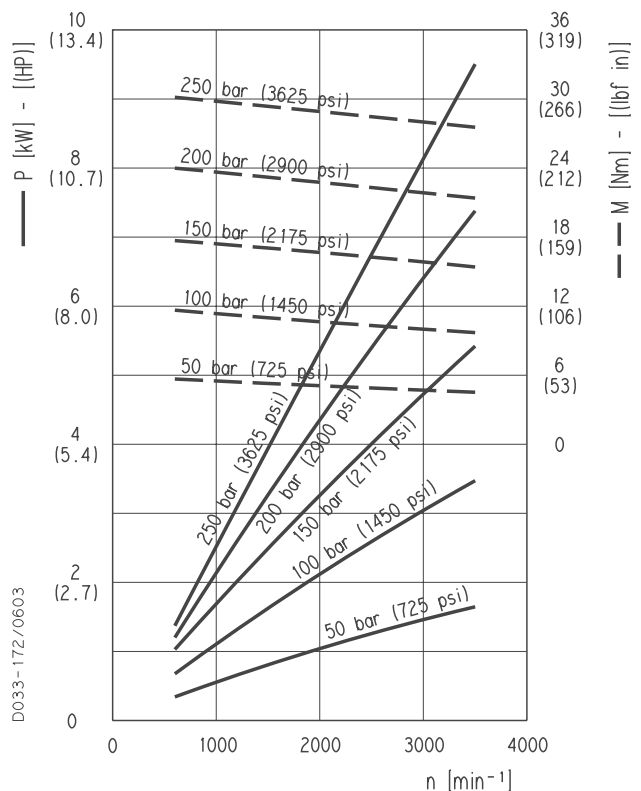

01/10.2003

**PLM 20**

**POLARIS 20 GEAR MOTORS PERFORMANCE CURVES**

**PLM 20•9**

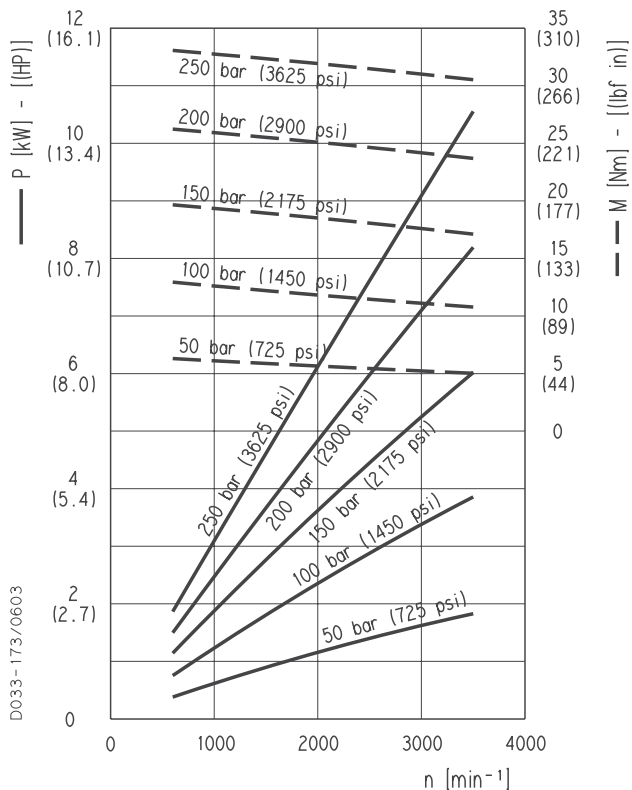

**PLM 20•10,5**

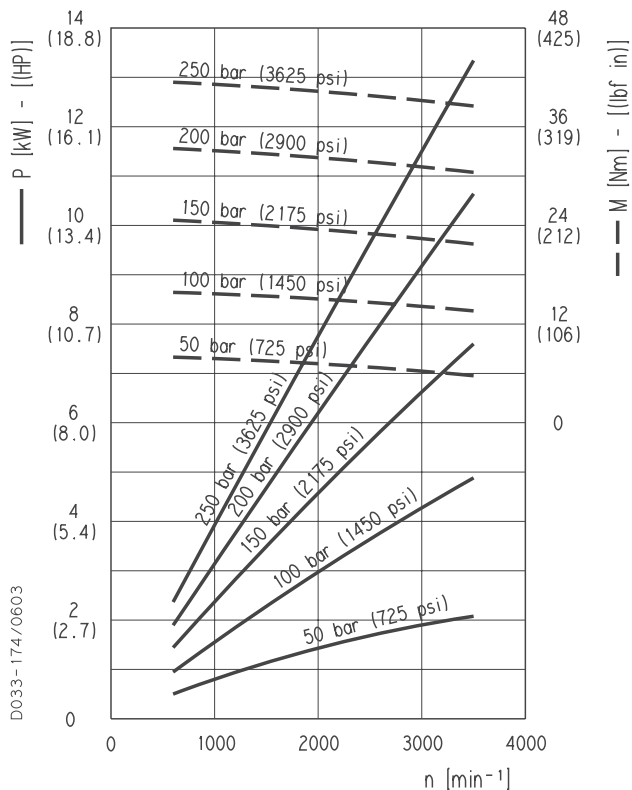

**PLM 20•11,2**

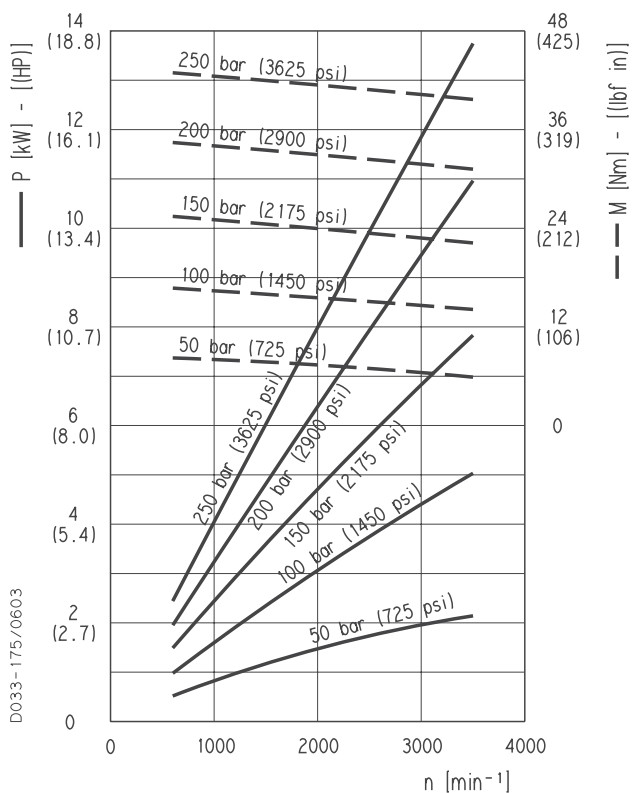

**PLM 20•14**

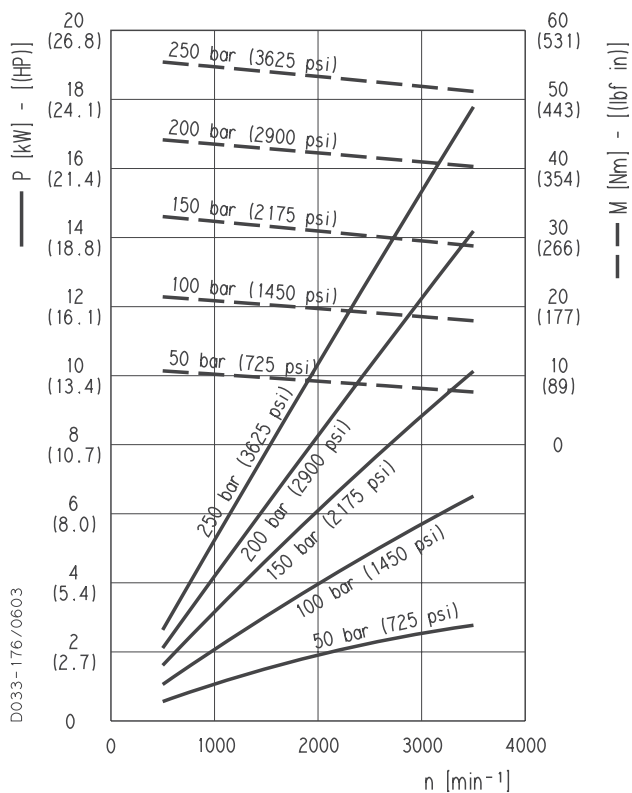

01/10.2003



**PLM 20**

**POLARIS 20 GEAR MOTORS PERFORMANCE CURVES**

**PLM 20•16**

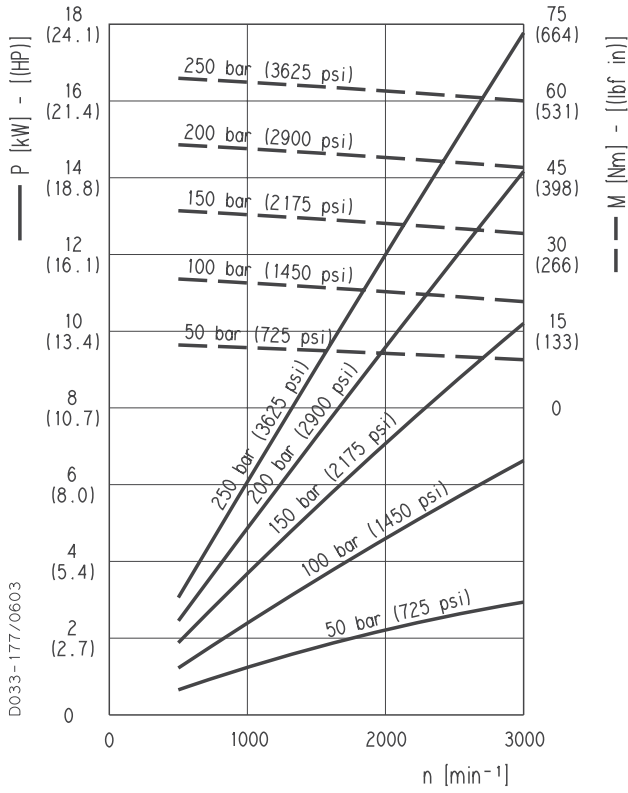

**PLM 20•19**

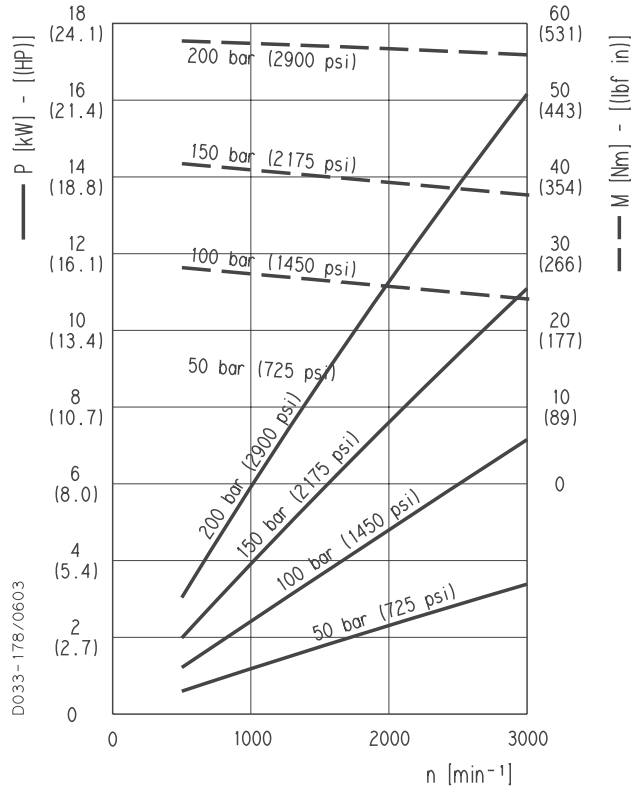

**PLM 20•20**

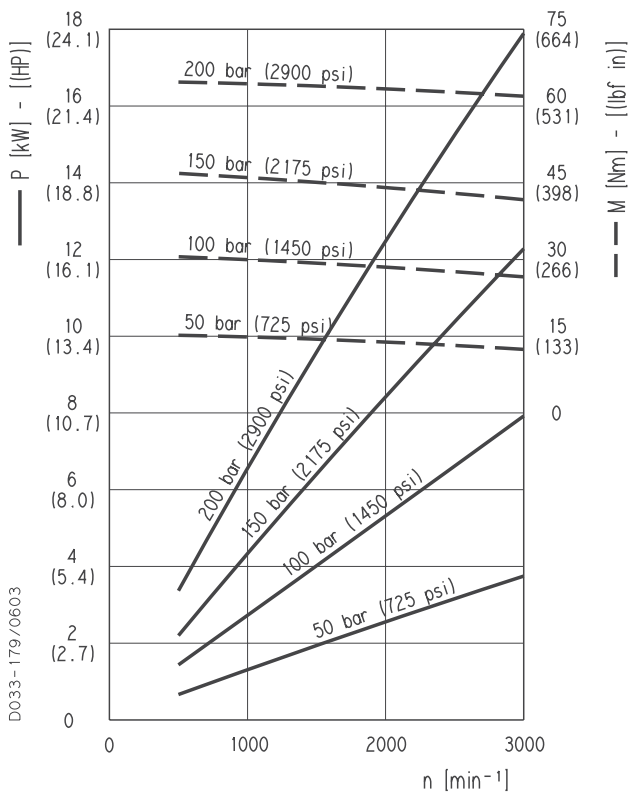

**PLM 20•24,5**

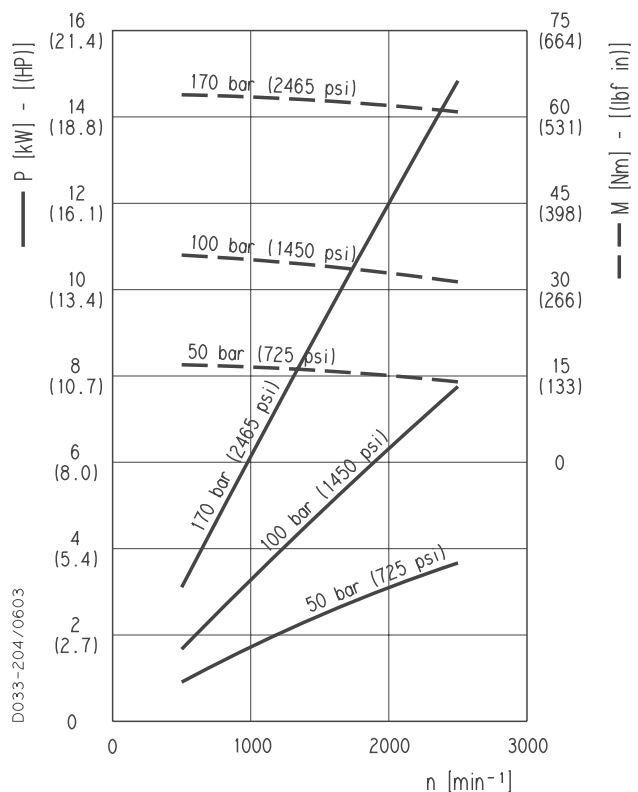

01/10.2003

**PLM 20**

**POLARIS 20 GEAR MOTORS PERFORMANCE CURVES**

**PLM 20•25**

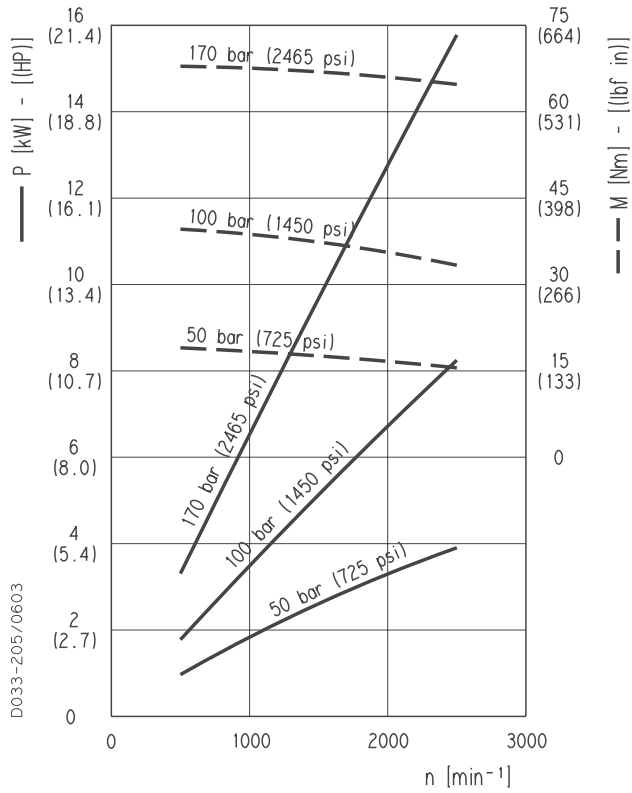

**PLM 20•27,8**

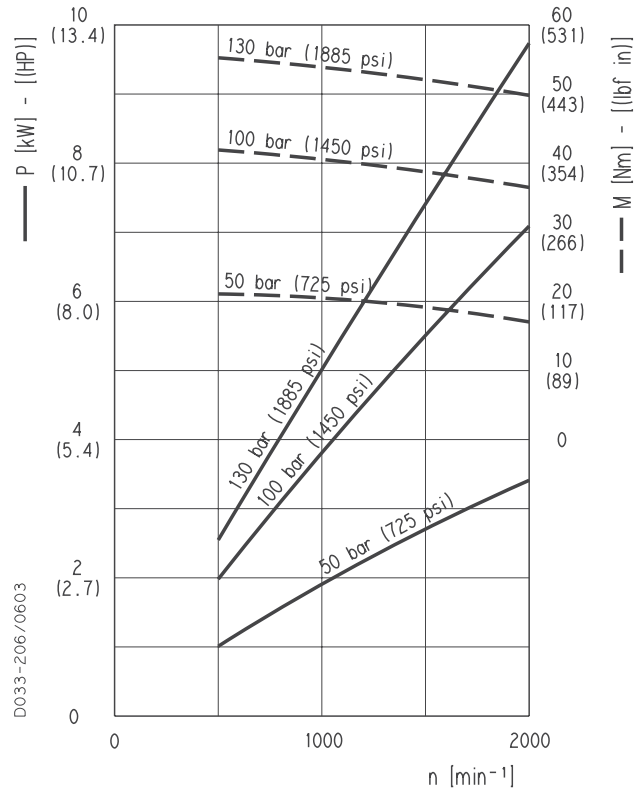

**PLM 20•31,5**

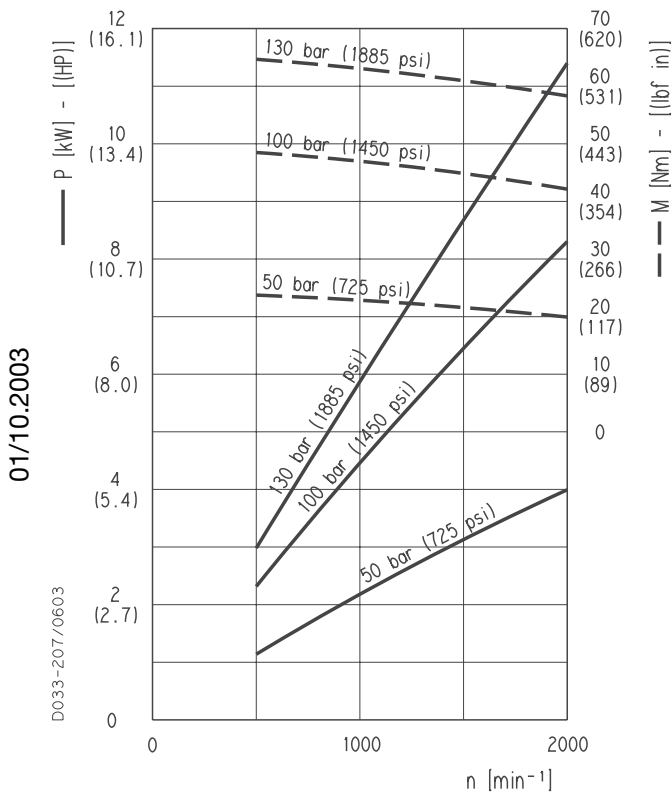

**PLM 30**

**POLARIS 30 GEAR MOTORS PERFORMANCE CURVES**

Each curve has been obtained at 50 °C (122 °F), using oil with viscosity 46 cSt (210 SSU) at 40 °C (104 °F) and at these pressures.

**PLM 30**

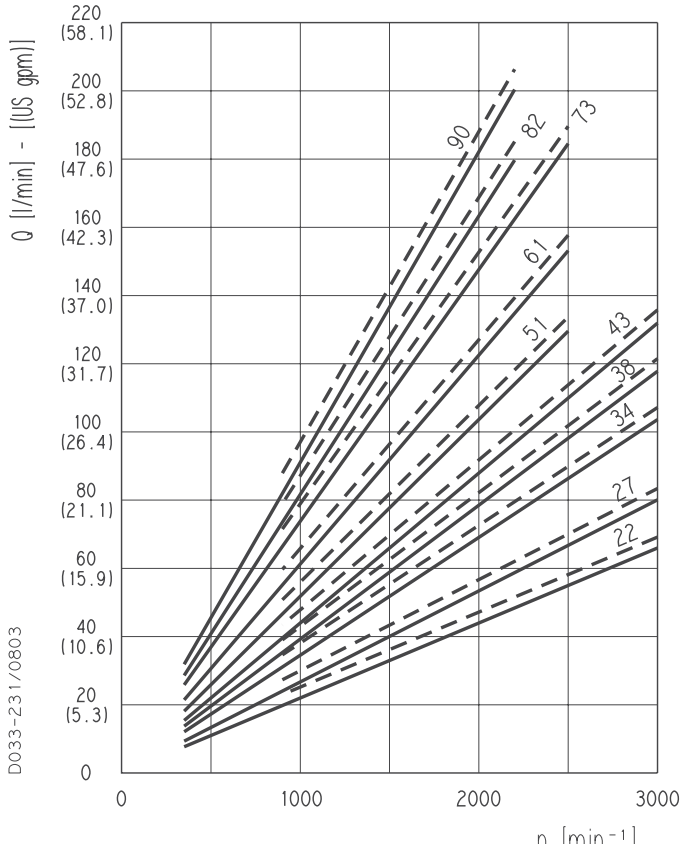

<b>PLM 30•22</b>	—	20 bar (290 psi)
	- - -	250 bar (3625 psi)
<b>PLM 30•27</b>	—	20 bar (290 psi)
	- - -	250 bar (3625 psi)
<b>PLM 30•34</b>	—	20 bar (290 psi)
	- - -	240 bar (3480 psi)
<b>PLM 30•38</b>	—	20 bar (290 psi)
	- - -	240 bar (3480 psi)
<b>PLM 30•43</b>	—	20 bar (290 psi)
	- - -	230 bar (3335 psi)
<b>PLM 30•51</b>	—	20 bar (290 psi)
	- - -	210 bar (3045 psi)
<b>PLM 30•61</b>	—	20 bar (290 psi)
	- - -	190 bar (2775 psi)
<b>PLM 30•73</b>	—	20 bar (290 psi)
	- - -	170 bar (2465 psi)
<b>PLM 30•82</b>	—	20 bar (290 psi)
	- - -	160 bar (2320 psi)
<b>PLM 30•90</b>	—	20 bar (290 psi)
	- - -	150 bar (2175 psi)

**PLM 30•22**

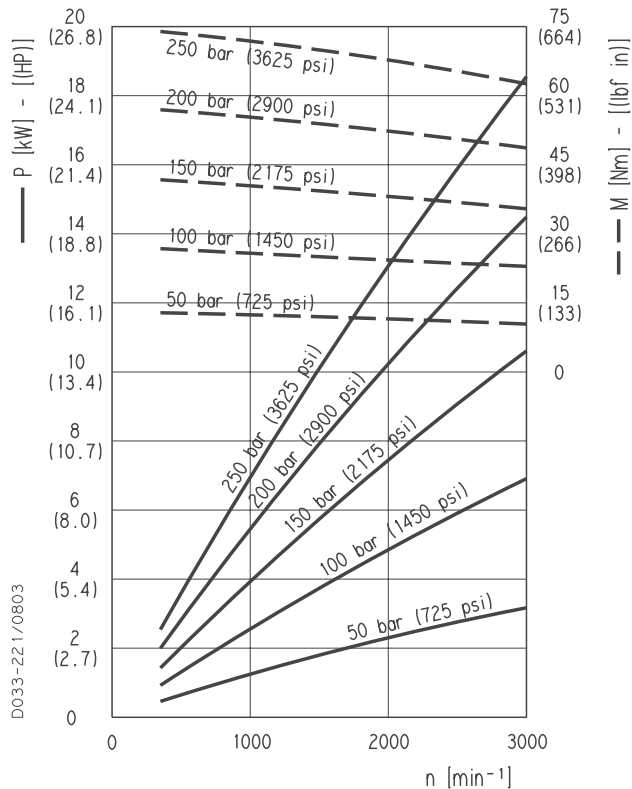

**PLM 30•27**

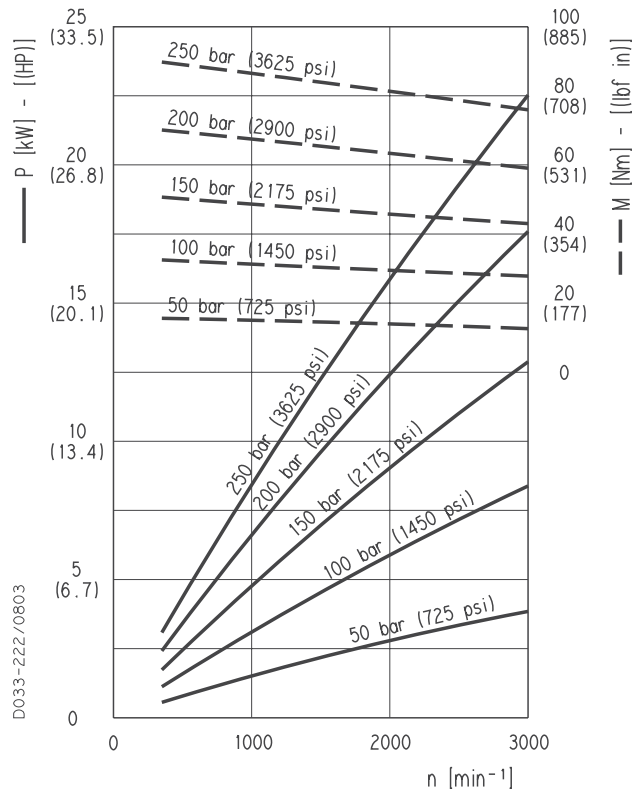

01/10.2003

**PLM 30**

**POLARIS 30 GEAR MOTORS PERFORMANCE CURVES**

**PLM 30•34**

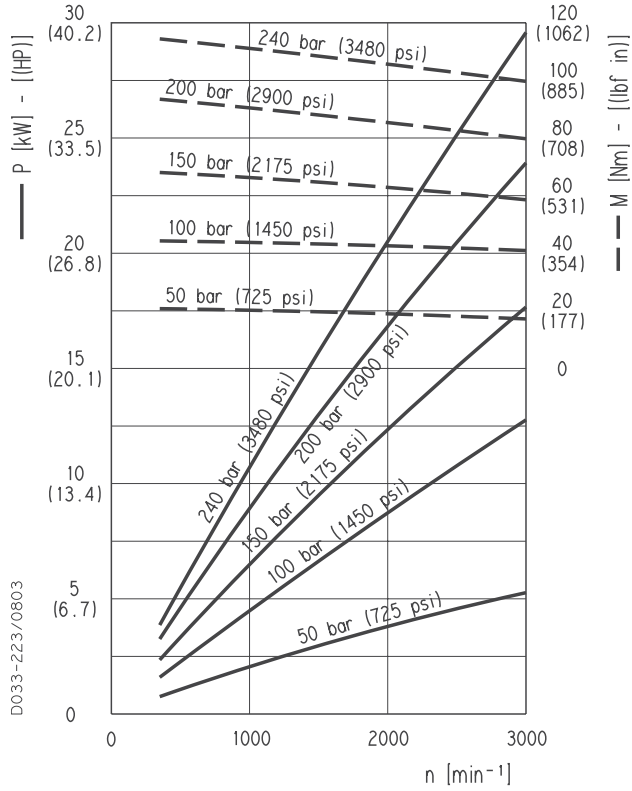

**PLM 30•38**

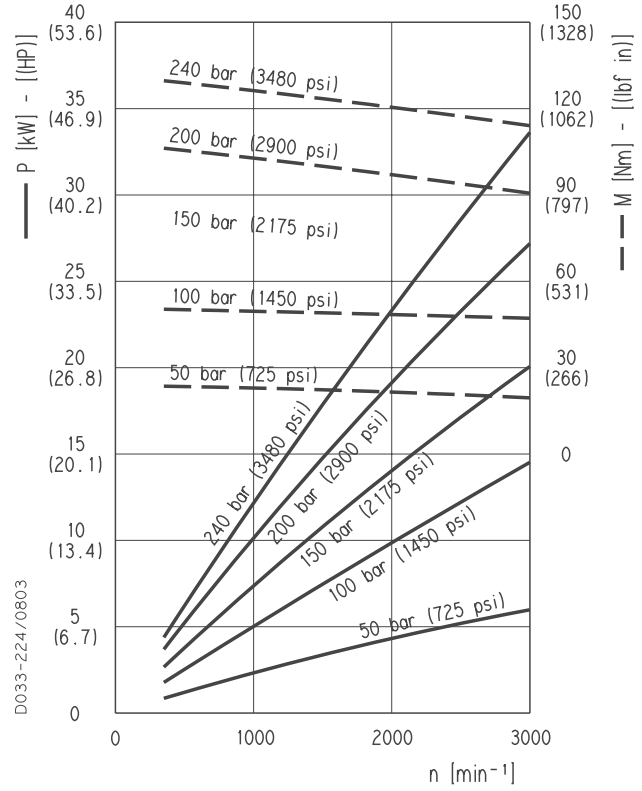

**PLM 20•43**

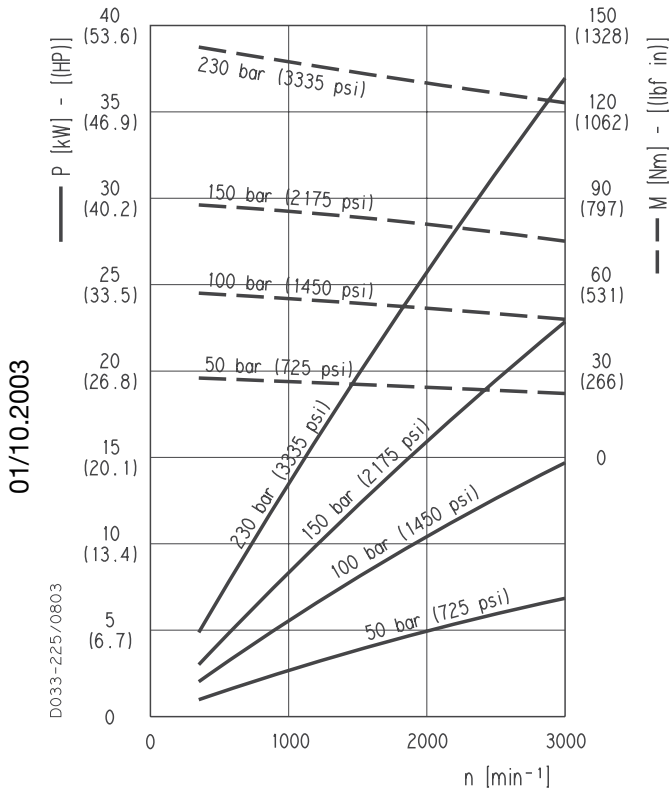

**PLM 20•51**

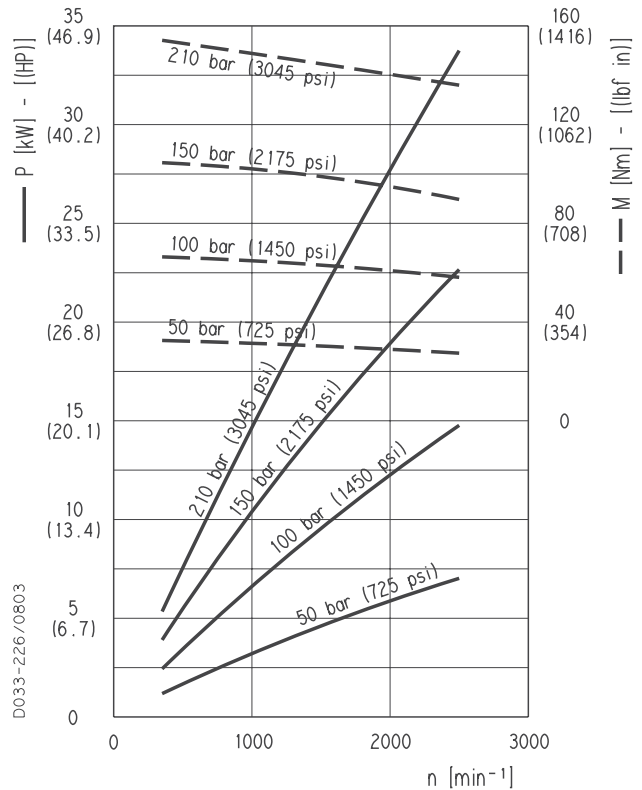

**PLM 30**

**POLARIS 30 GEAR MOTORS PERFORMANCE CURVES**

**PLM 30•61**

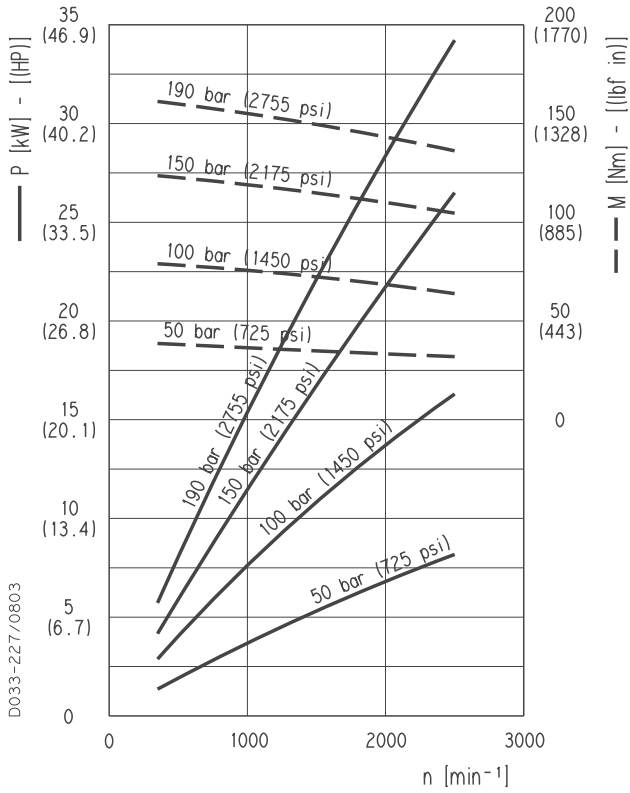

**PLM 30•73**

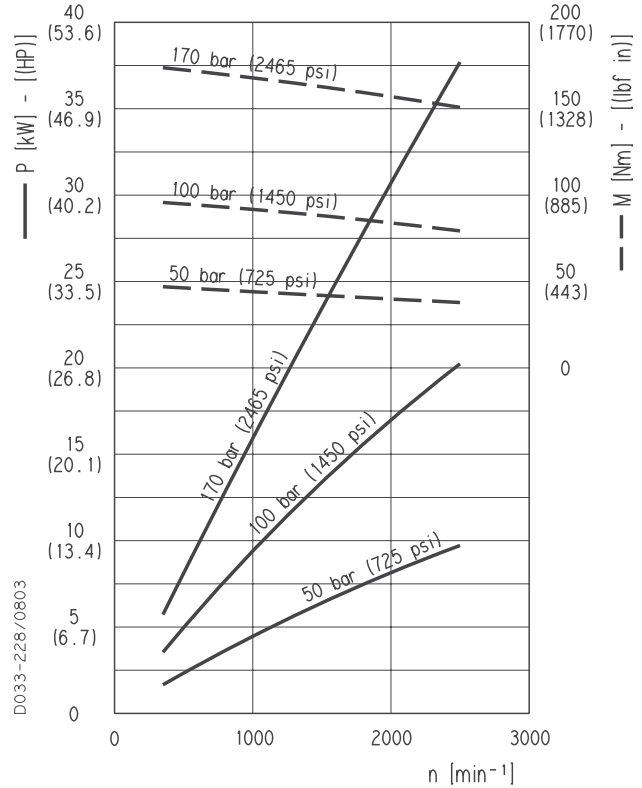

**PLM 30•82**

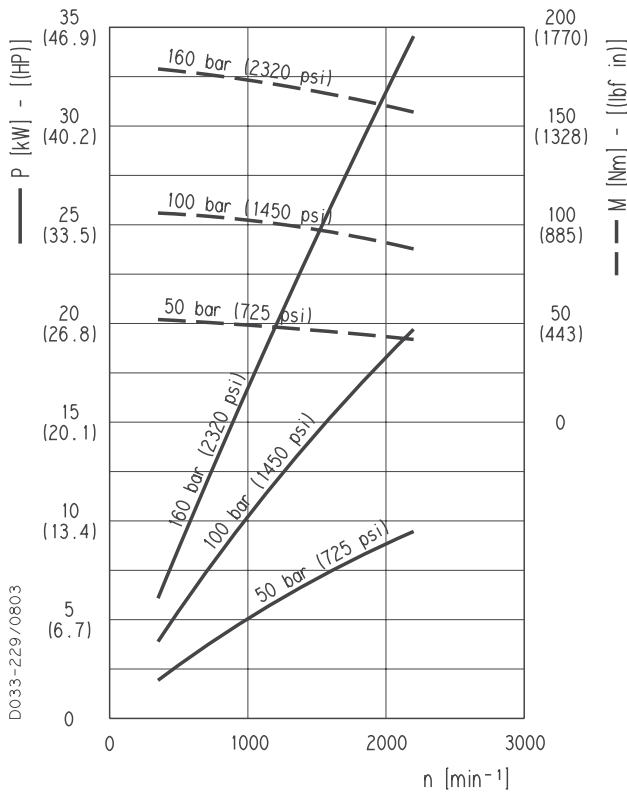

**PLM 30•90**

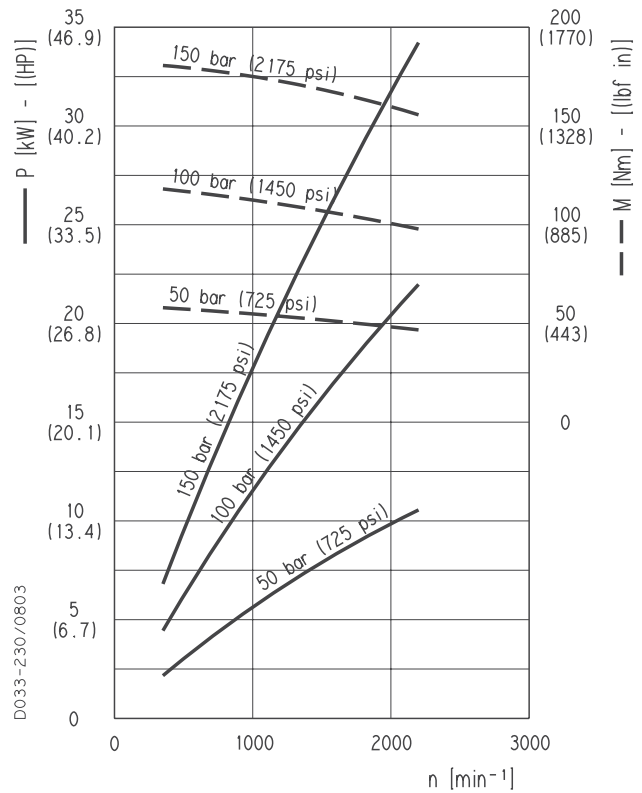

01/10.2003

---

## NOTES

---

04/10.2020

**POLARIS 10**

**SINGLE UNITS DIMENSIONS - SIDE PORTS**

**L**

Drive shafts: page 52  
Mounting flange: for X dimension see page 58 ÷ 60

Ports availability: Gas, SAE, German. See page 70

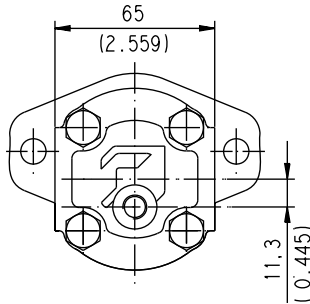

**Reversible R**

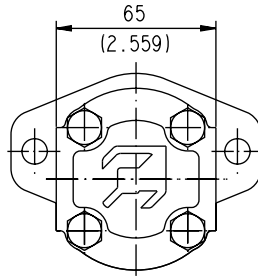

**Single rotation S - D**

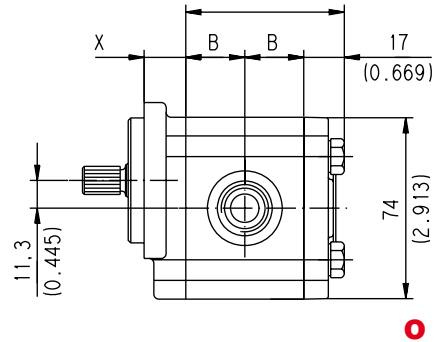

D033-180/0903

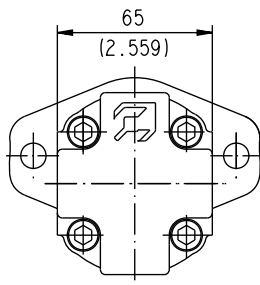

**Reversible B**

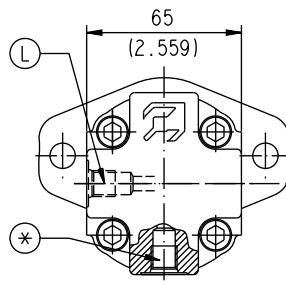

**Reversible L**

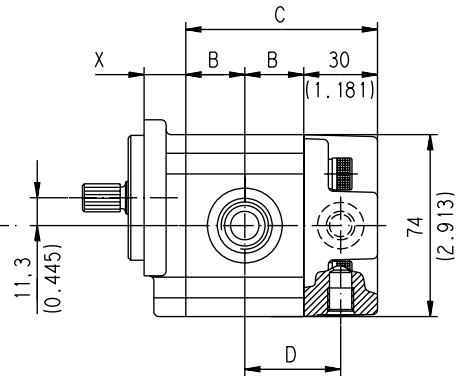

Replaces: 02/07.2006

For single rotation S - D and reversible rotation R the rear cover is available in cast iron and aluminium.

For reversible rotation B and L the rear cover is in aluminium only.

Reversible L drain port position:

L = Side

\* = Bottom

Pump type Motor type	<b>A</b>	<b>B</b>	<b>C</b>	<b>D</b>
	mm (in)	mm (in)	mm (in)	mm (in)
<b>PL. 10•1</b>	52,2 (2.0551)	17,6 (0.6929)	65,2 (2.5669)	32,6 (1.2835)
<b>PL. 10•1,5</b>	53,8 (2.1181)	18,4 (0.7244)	66,8 (2.6299)	33,4 (1.3150)
<b>PL. 10•2</b>	55,4 (2.1811)	19,2 (0.7559)	68,4 (2.6929)	34,2 (1.3465)
<b>PL. 10•2,5</b>	57 (2.2441)	20 (0.7874)	70 (2.7559)	35 (1.3780)
<b>PL. 10•3,15</b>	59 (2.3228)	21 (0.8268)	72 (2.8346)	36 (1.4173)
<b>PL. 10•4</b>	61,8 (2.4331)	22,4 (0.8819)	74,8 (2.9449)	37,4 (1.4724)
<b>PL. 10•5</b>	65 (2.5591)	24 (0.9449)	78 (3.0709)	39 (1.5354)
<b>PL. 10•5,8</b>	67,6 (2.6614)	25,3 (0.9961)	80,6 (3.1732)	40,3 (1.5866)
<b>PL. 10•6,3</b>	69 (2.7165)	26 (1.0236)	82 (3.2283)	41 (1.6142)
<b>PL. 10•8</b>	74,5 (2.9331)	28,75 (1.1319)	87,5 (3.4449)	43,75 (1.7224)
<b>PL. 10•10</b>	81 (3.1890)	32 (1.2598)	94 (3.7008)	47 (1.8504)

04/10.2020

**POLARIS 10**

**SINGLE UNITS DIMENSIONS - REAR PORTS**

**P**

Drive shafts: page 52

Ports availability: Gas, SAE

Mounting flange: for X dimension see  
page 58 ÷ 60

See page 70

Replaces: 02/07.2006

D033-181/0903

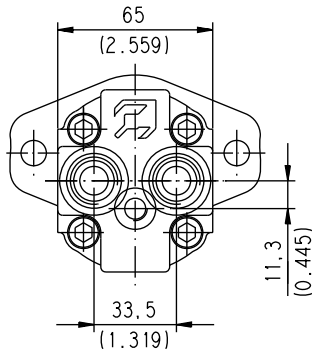

**Reversible R**

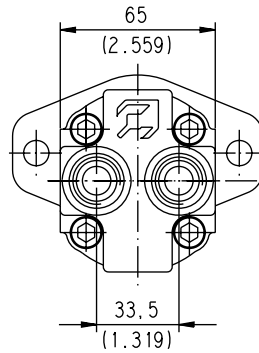

**Single rotation S - D**

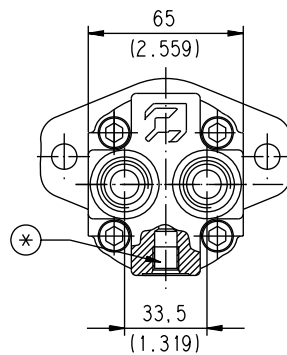

**Reversible L**

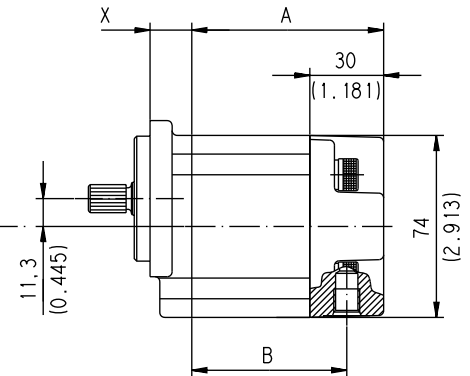
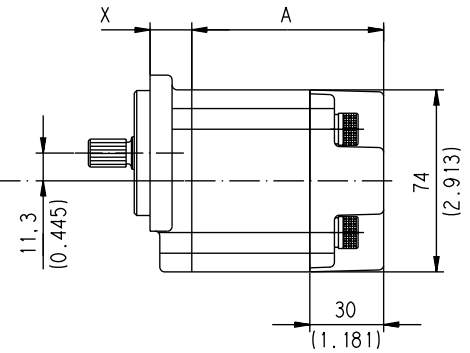

Rear cover in aluminium only.

Reversible L drain port position:  
\* = Bottom

04/10.2020

Pump type	A	B
Motor type	mm (in)	mm (in)
<b>PL. 10•1</b>	65,2 (2.5669)	50,2 (1.9764)
<b>PL. 10•1,5</b>	66,8 (2.6299)	51,8 (2.0394)
<b>PL. 10•2</b>	68,4 (2.6929)	53,4 (2.0124)
<b>PL. 10•2,5</b>	70 (2.7559)	55 (2.1654)
<b>PL. 10•3,15</b>	72 (2.8346)	57 (2.2441)
<b>PL. 10•4</b>	74,8 (2.9449)	59,8 (2.3543)
<b>PL. 10•5</b>	78 (3.0709)	63 (2.4803)
<b>PL. 10•5,8</b>	80,6 (3.1732)	65,6 (2.5827)
<b>PL. 10•6,3</b>	82 (3.2283)	67 (2.6378)
<b>PL. 10•8</b>	87,5 (3.4449)	72,5 (2.8543)
<b>PL. 10•10</b>	94 (3.7008)	79 (3.1102)



**POLARIS 20**

**SINGLE UNITS DIMENSIONS - SIDE PORTS**

**L**

Drive shafts: page 53 ÷ 55  
Mounting flange: for X dimension see page 61 ÷ 66

Ports availability: European, Split, Gas, SAE German. See page 70

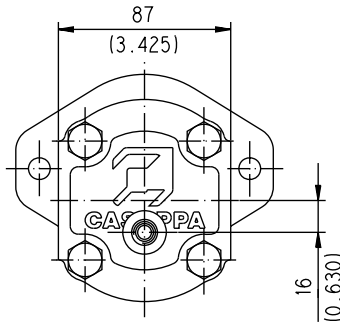

**Reversible R**

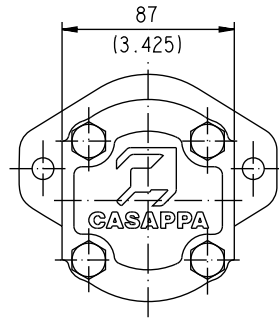

**Single rotation S - D and Reversible B**

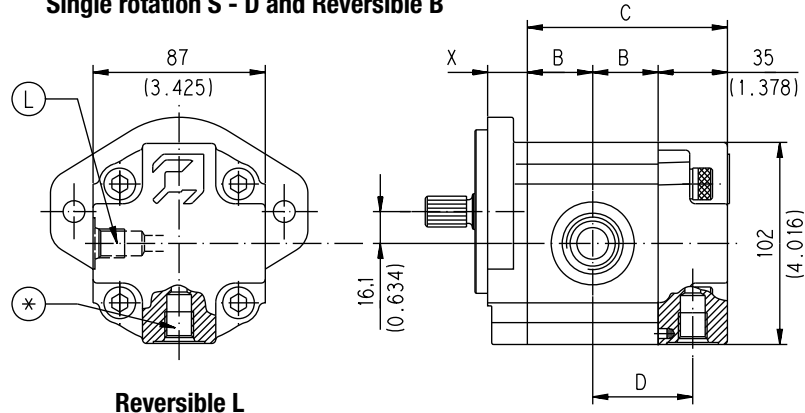
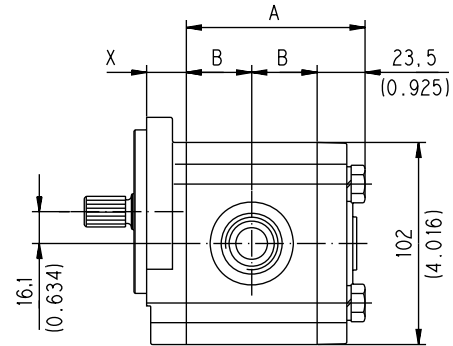

**Reversible L**

For single rotation S - D and reversible B and R the rear cover is available in cast iron and aluminium.  
For reversible rotation L the rear cover is in aluminium only.

Reversible L drain port position:  
L = Side  
\* = Bottom

Replaces: 02/07.2006

D033-182/0903

Pump type Motor type	<b>A</b>	<b>B</b>	<b>C</b>	<b>D</b>
	mm (in)	mm (in)	mm (in)	mm (in)
<b>PL 20•4</b>	75 (2.9528)	25,75 (1.0138)	86,5 (3.4055)	43,25 (1.7028)
<b>PL 20•6,3</b>	77,5 (3.0512)	27 (1.0630)	89 (3.5039)	44,5 (1.7520)
<b>PL 10•7,2</b>	78,5 (3.0917)	27,5 (1.083)	90 (3.5445)	45 (1.7722)
<b>PL 20•8</b>	80 (3.1496)	28,25 (1.1122)	91,5 (3.6024)	45,75 (1.8012)
<b>PL 20•9</b>	81,3 (3.2008)	28,9 (1.1378)	92,8 (3.6535)	46,4 (1.8268)
<b>PL 20•10,5</b>	84 (3.3070)	30,25 (1.1909)	95,5 (3.7598)	47,75 (1.8799)
<b>PL 20•11,2</b>	84,5 (3.3268)	30,5 (1.2008)	96 (3.7795)	48 (1.8898)
<b>PL 20•14</b>	89,5 (3.5236)	33 (1.2992)	101 (3.9764)	50,5 (1.9882)
<b>PL 20•16</b>	93 (3.6614)	34,75 (1.3681)	104,5 (4.1142)	52,25 (2.0571)
<b>PL 20•19</b>	96,4 (3.7952)	36,45 (1.4350)	107,9 (4.2480)	53,9 (2.12)
<b>PL 20•20</b>	99,5 (3.9173)	38 (1.4961)	111 (4.3701)	55,5 (2.1850)
<b>PL 20•24,5</b>	105,1 (4.1378)	40,8 (1.6063)	116,6 (4.5905)	58,3 (2.2953)
<b>PL 20•25</b>	107,5 (4.2323)	42 (1.6535)	119 (4.6850)	59,5 (2.3425)
<b>PL 20•27,8</b>	110,2 (4.3386)	43,35 (1.7067)	121,7 (4.7913)	60,85 (2.3957)
<b>PL 20•31,5</b>	117,5 (4.6260)	47 (1.8504)	129 (5.0787)	64,5 (2.5394)

04/10.2020

**POLARIS 20**

**SINGLE UNITS DIMENSIONS - REAR PORTS**

**P**

Drive shafts: page 53 ÷ 55

Ports availability: Gas, SAE.

Mounting flange: for X dimension see page 61 ÷ 66

See page 70

Replaces: 02/07.2006

D033-183/0903

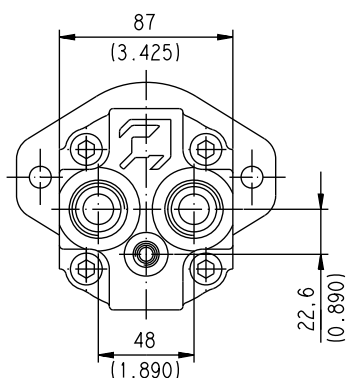

**Reversible R**

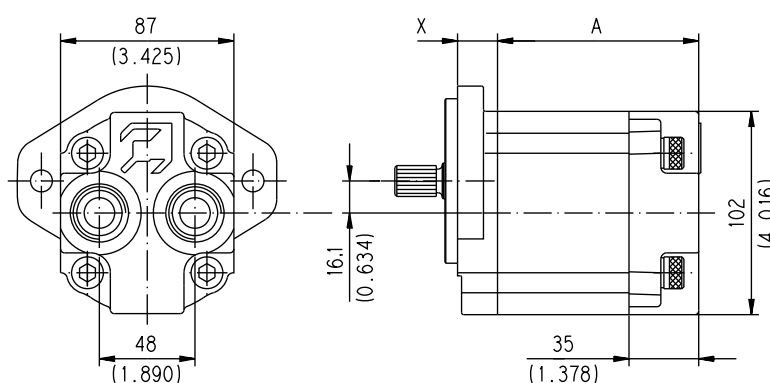

**Single rotation S - D and Reversible B**

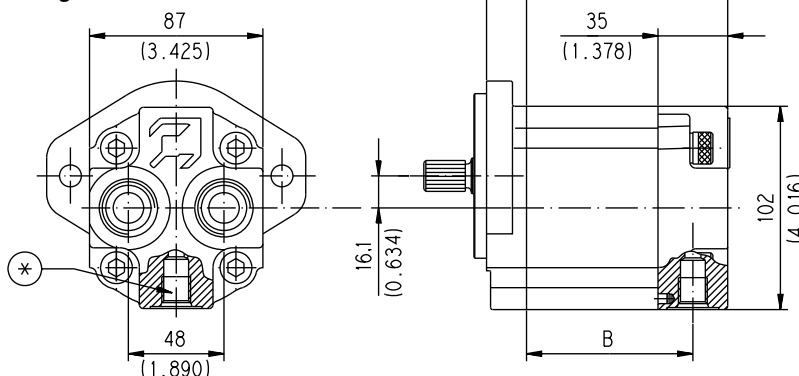

**Reversible L**

Rear cover in aluminium only.

Reversible L drain port position:

\*= Bottom

04/10.2020

Pump type Motor type	<b>A</b>		<b>B</b>	
	mm (in)		mm (in)	
<b>PL. 20•4</b>	86,5	(3.4055)	69	(2.7165)
<b>PL. 20•6,3</b>	89	(3.5039)	71,5	(2.8150)
<b>PL. 10•7,2</b>	90	(3.5445)	72,5	(2.8555)
<b>PL. 20•8</b>	91,5	(3.6024)	74	(2.9134)
<b>PL. 20•9</b>	92,8	(3.6535)	75,3	(2.9646)
<b>PL. 20•10,5</b>	95,5	(3.7598)	78	(3.0708)
<b>PL. 20•11,2</b>	96	(3.7795)	78,5	(3.0906)
<b>PL. 20•14</b>	101	(3.9764)	83,5	(3.2874)
<b>PL. 20•16</b>	104,5	(4.1142)	87	(3.4252)
<b>PL. 20•19</b>	107,9	(4.2480)	90,4	(3.5591)
<b>PL. 20•20</b>	111	(4.3701)	93,5	(3.6811)
<b>PL. 20•24,5</b>	116,6	(4.5905)	99,1	(3.9016)
<b>PL. 20•25</b>	119	(4.6850)	101,5	(3.9961)
<b>PL. 20•27,8</b>	121,7	(4.7913)	104,2	(4.1024)
<b>PL. 20•31,5</b>	129	(5.0787)	111,5	(4.3898)

**POLARIS 30**

**SINGLE UNITS DIMENSIONS - SIDE PORTS**

**L**

Drive shafts: page 56 ÷ 57

Ports availability: European, Split, Gas,  
SAE German. See page 70

Mounting flange: for X dimension see  
page 67 ÷ 69

D033-184/0903

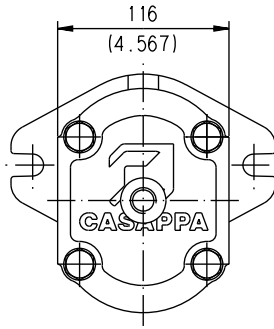

**Reversible R**

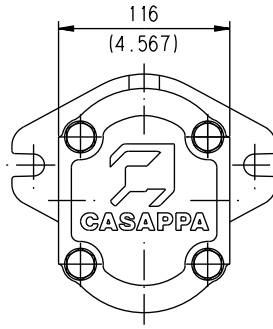

**Single rotation S - D**

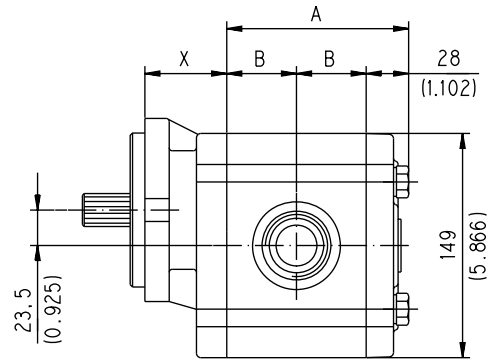

**O**

Replaces: 03/02.2012

Rear cover in cast iron only.

Pump type Motor type	<b>A</b>	<b>B</b>
	mm (in)	mm (in)
<b>PL. 30•22</b>	106 (4.1732)	39 (1.5354)
<b>PL. 30•27</b>	109 (4.2913)	40,5 (1.5945)
<b>PL. 30•34</b>	114 (4.4882)	43 (1.6929)
<b>PL. 30•38</b>	117 (4.6063)	44,5 (1.7520)
<b>PL. 30•43</b>	120 (4.7244)	46 (1.8110)
<b>PL. 30•51</b>	125 (4.9212)	48,5 (1.9094)
<b>PL. 30•61</b>	131 (5.1575)	51,5 (2.0276)
<b>PL. 30•73</b>	139 (5.4724)	55,5 (2.1850)
<b>PL. 30•82</b>	144 (5.6693)	58 (2.2835)
<b>PL. 30•90</b>	150 (5.9055)	61 (2.4016)

04/10.2020

## MULTIPLE PUMPS

POLARIS series pumps can be coupled together in combination. Where the input power requirements of each section varies, that with the greater requirement must be at the drive shaft end, and progressively smaller to the rear.

Features and performances are the same as the corresponding single pumps, but pressures must be limited by the transmissible torque of the drive and connecting shafts. To have appropriate data, use the formula below.

The maximum rotational speed is that of the lowest rated speed of the single units incorporated.

Available with common inlet and separated stages. For more information please consult our pre-sales department.

<b>M</b>	Nm (lbf in)	Torque
<b>V</b>	cm <sup>3</sup> /rev (in <sup>3</sup> /rev)	Displacement
<b>Δp</b>	bar (psi)	Pressure
$\eta_{hm} = \eta_{hm}(V, \Delta p, n)$	(≈ 0,88)	Hydro-mechanical efficiency

$$M = \frac{M_{theor.}}{\eta_{hm}} \quad [Nm]$$

$$M_{theor.} = \frac{\Delta p \text{ (bar)} \cdot V \text{ (cm}^3\text{/rev)}}{62,83} \quad [Nm]$$

### NOTE

The torque absorbed from the shaft of the first pump results from the sum of the torques of all the single stages. The achieved value must not exceed the maximum torque limit given for the shaft of the first pump.

03/02.2012

## COMMON INLET - PORTS POSITION

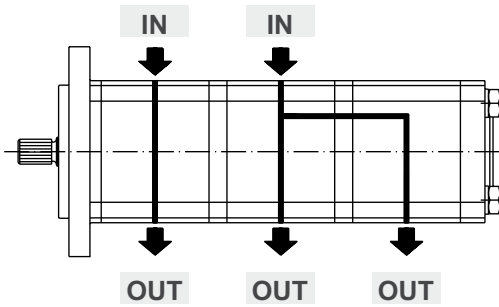
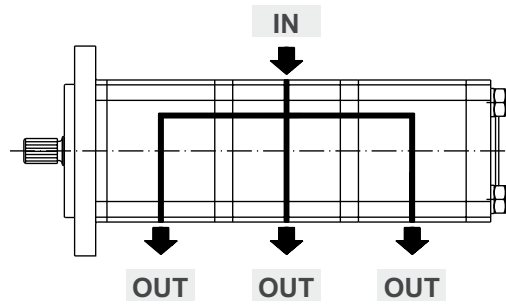
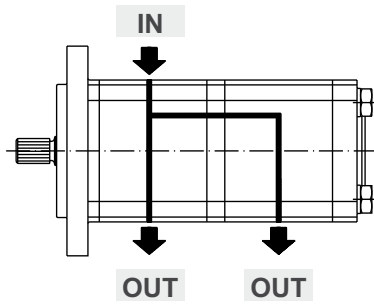

Reduced inlets provide overall systems savings by reducing the cost of redundant inlet hose and fittings.

For other combinations please consult our pre-sales department.

## MULTIPLE PUMPS COMBINATION

**PL10**

Polaris 10/10	STANDARD VERSION	<b>V6</b>
Polaris 10/10	COMMON INLET VERSION	<b>V7</b>

D033-112/0603

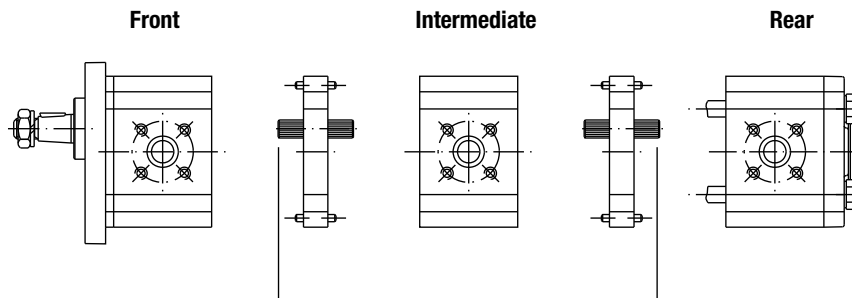

**88** MAX 30 Nm (266 lbf in)

**88** MAX 30 Nm (266 lbf in)

02/07.2006

**MULTIPLE PUMPS COMBINATION**

**PLP 20**

<b>Polaris 20/20</b>	<b>STANDARD VERSION</b>	<b>S6</b>
<b>Polaris 20/20</b>	<b>COMMON INLET VERSION</b>	<b>S7</b>

Replaces: 02/07.2006

D033-106/0603

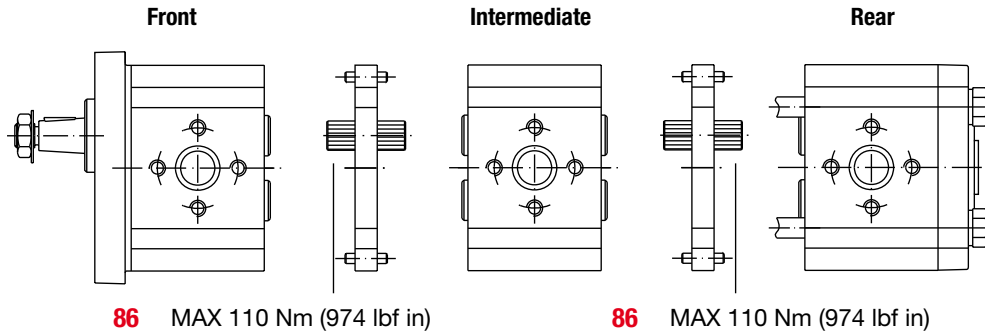

<b>Polaris 20/20</b>	<b>SEPARATED SRAGES VERSION</b>	<b>Z6</b>
----------------------	---------------------------------	-----------

D033-110/0603

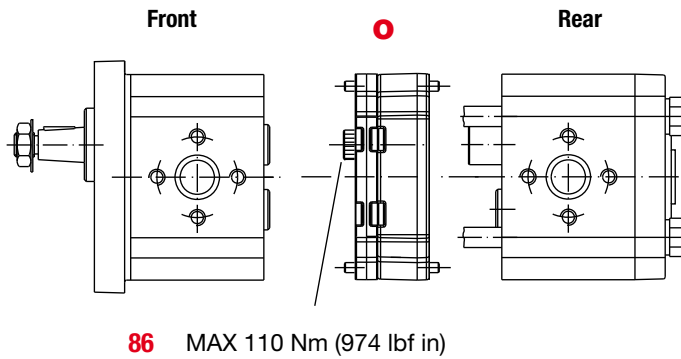

<b>Polaris 20/10</b>	<b>STANDARD VERSION</b>	<b>T6</b>
<b>Polaris 20/10</b>	<b>COMMON INLET VERSION</b>	<b>T7</b>

04/10.2020

D033-107/0603

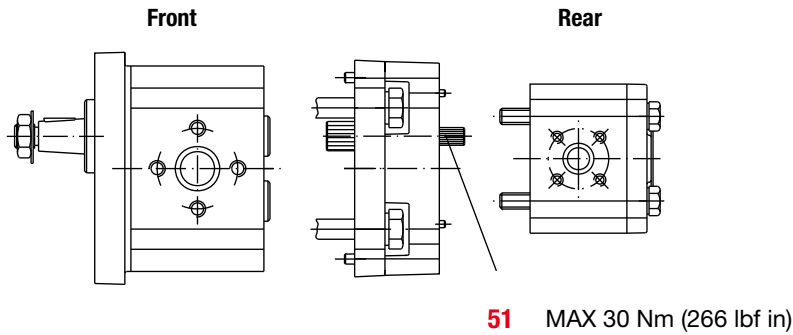

<b>Polaris 20/10</b>	<b>SEPARATED SRAGES VERSION</b>	<b>Z6</b>
----------------------	---------------------------------	-----------

D033-111/0603

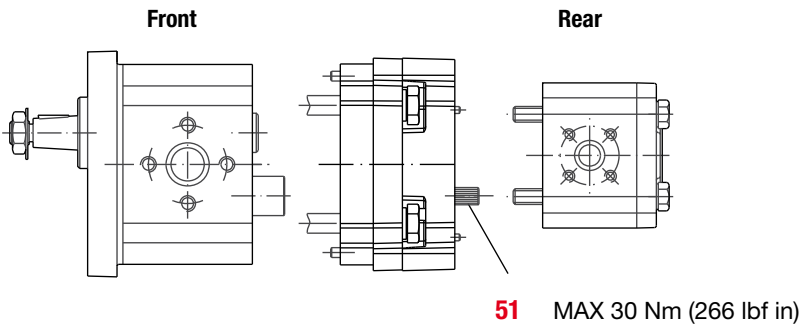

**MULTIPLE PUMPS COMBINATION**

**PLP 30**

**Polaris 30/30**

**STANDARD VERSION**

**M6**

**Front**

**Intermediate**

**Rear**

D033-100/0603

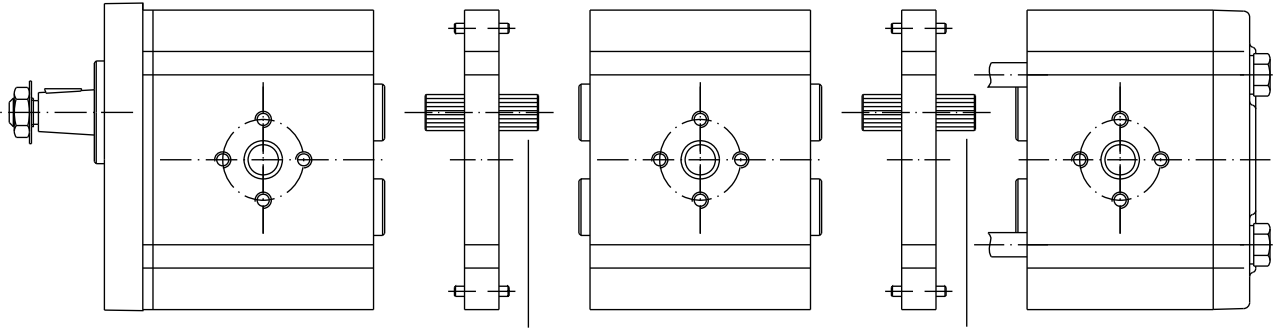

**65** MAX 170 Nm (1505 lbf in) **○** **65** MAX 170 Nm (1505 lbf in)

Replaces: 02/07.2006

**Polaris 30/20**

**STANDARD VERSION**

**N6**

**Polaris 30/20**

**COMMON INLET VERSION**

**N7**

**Front**

**Rear**

D033-101/0603

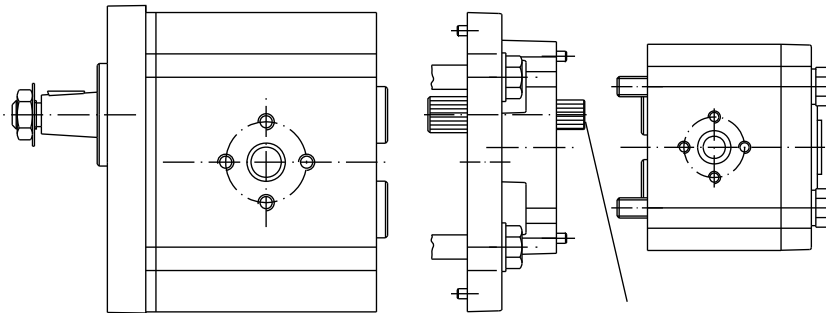

**83** MAX 110 Nm (974 lbf in)

**Polaris 30/20**

**SEPARATED SRAGES VERSION**

**Z6**

**Front**

**Rear**

D033-105/0603

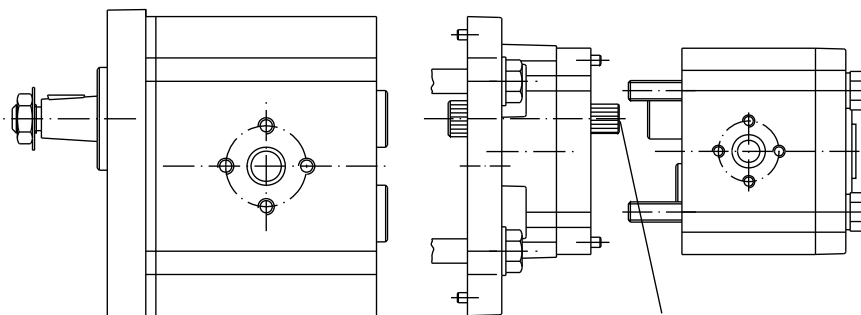

**83** MAX 110 Nm (974 lbf in)

**○** 04/10.2020

**MULTIPLE PUMPS COMBINATION**

**PLP 30**

<b>Polaris 30/20</b>	<b>STANDARD VERSION</b>	<b>Q6</b>
<b>Polaris 30/10</b>	<b>COMMON INLET VERSION</b>	<b>Q7</b>

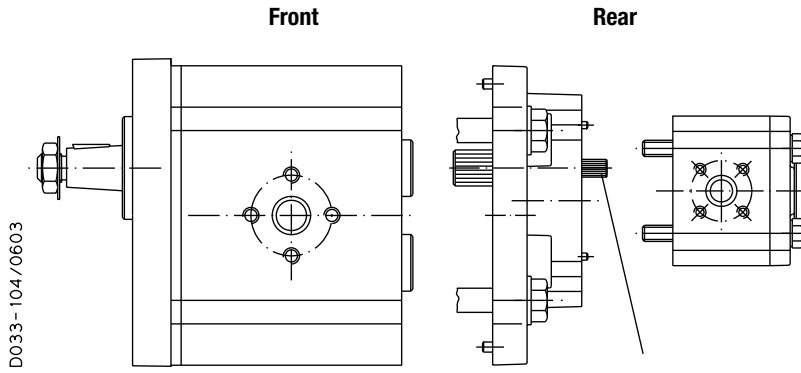

**52** MAX 30 Nm (266 lbf in)

02/07.2006



**POLARIS 10**

**MULTIPLE PUMPS DIMENSIONS**

**PLP10**

Drive shafts: page 52  
Mounting flange: for X dimension see page 58 ÷ 60

Ports availability: Gas, SAE,  
German. See page 70

D033-190/0903

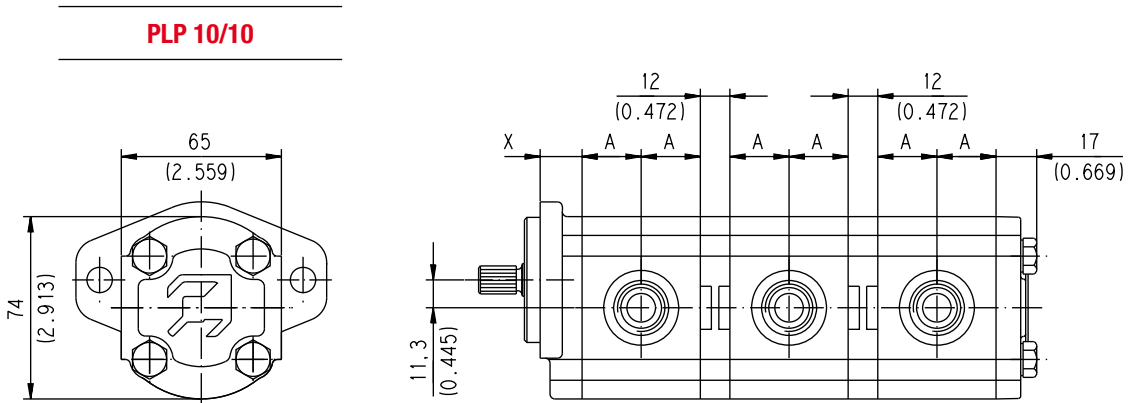

Replaces: 02/07.2006

Rear cover available in cast iron and aluminium.

Pump type	<b>A</b>
	mm (in)
<b>PLP. 10•1</b>	17,6 (0.6929)
<b>PLP. 10•1,5</b>	18,4 (0.7244)
<b>PLP. 10•2</b>	19,2 (0.7559)
<b>PLP. 10•2,5</b>	20 (0.7874)
<b>PLP. 10•3,15</b>	21 (0.8268)
<b>PLP. 10•4</b>	22,4 (0.8819)
<b>PLP. 10•5</b>	24 (0.9449)
<b>PLP. 10•5,8</b>	25,3 (0.9961)
<b>PLP. 10•6,3</b>	26 (1.0236)
<b>PLP. 10•8</b>	28,7 (1.1319)
<b>PLP. 10•10</b>	32 (1.2598)

04/10.2020

**POLARIS 20**

**MULTIPLE PUMPS DIMENSIONS**

**PLP 20**

Drive shafts: page 53 ÷ 55  
Mounting flange: for X dimension see page 61 ÷ 65

Ports availability: European, Split, Gas, SAE German. See page 70

Replaces: 02/07.2006

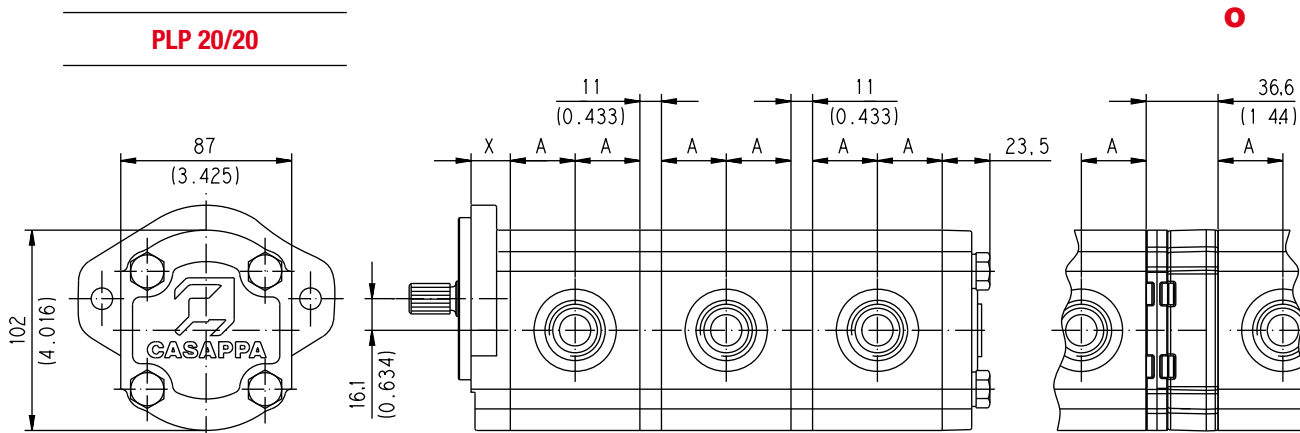

**O**

Separated stages

D033-261/0903

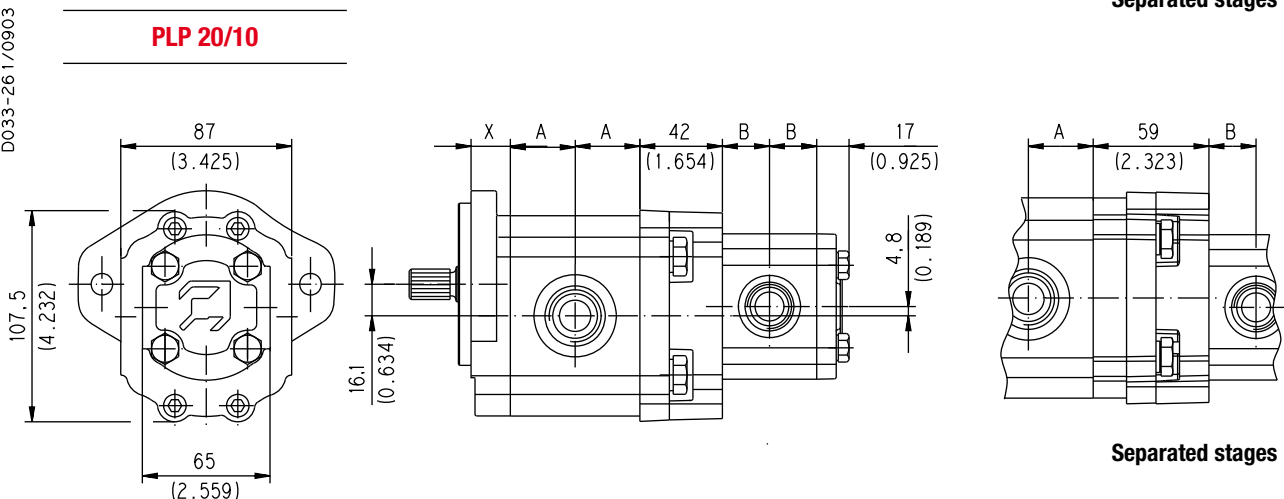

Separated stages

Pump type	<b>A</b> mm (in)
<b>PLP 20•4</b>	25,75 (1.0138)
<b>PLP 20•6,3</b>	27 (1.0630)
<b>PLP 20•7,2</b>	27,5 (1.0827)
<b>PLP 20•8</b>	28,25 (1.1122)
<b>PLP 20•9</b>	28,9 (1.1378)
<b>PLP 20•10,5</b>	30,25 (1.1909)
<b>PLP 20•11,2</b>	30,5 (1.2008)
<b>PLP 20•14</b>	33 (1.2992)
<b>PLP 20•16</b>	34,75 (1.3681)
<b>PLP 20•19</b>	36,45 (1.4350)
<b>PLP 20•20</b>	38 (1.4961)
<b>PLP 20•24,5</b>	40,8 (1.6063)
<b>PLP 20•25</b>	42 (1.6535)
<b>PLP 20•27,5</b>	43,35 (1.7067)
<b>PLP 20•31,5</b>	47 (1.8504)

Rear cover available in cast iron and aluminium.

Pump type	<b>B</b> mm (in)
<b>PLP 10•1</b>	17,6 (0.6929)
<b>PLP 10•1,5</b>	18,4 (0.7244)
<b>PLP 10•2</b>	19,2 (0.7559)
<b>PLP 10•2,5</b>	20 (0.7874)
<b>PLP 10•3,15</b>	21 (0.8268)
<b>PLP 10•4</b>	22,4 (0.8819)
<b>PLP 10•5</b>	24 (0.9449)
<b>PLP 10•5,8</b>	25,3 (0.9961)
<b>PLP 10•6,3</b>	26 (1.0236)
<b>PLP 10•8</b>	28,75 (1.1319)
<b>PLP 10•10</b>	32 (1.2598)

04/10.2020

**O**

**POLARIS 30**

**MULTIPLE PUMPS DIMENSIONS**

**PLP30**

Drive shafts: page 56 ÷ 57  
Mounting flange: for X dimension see page 67 ÷ 69

Ports availability: European, Split, Gas, SAE German. See page 70

Replaces: 02/07.2008

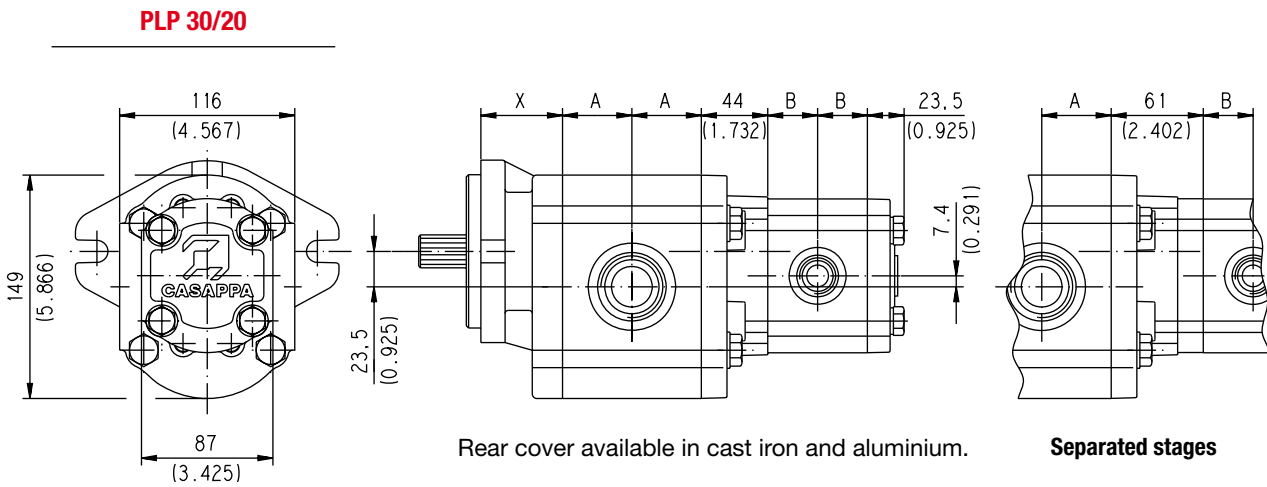
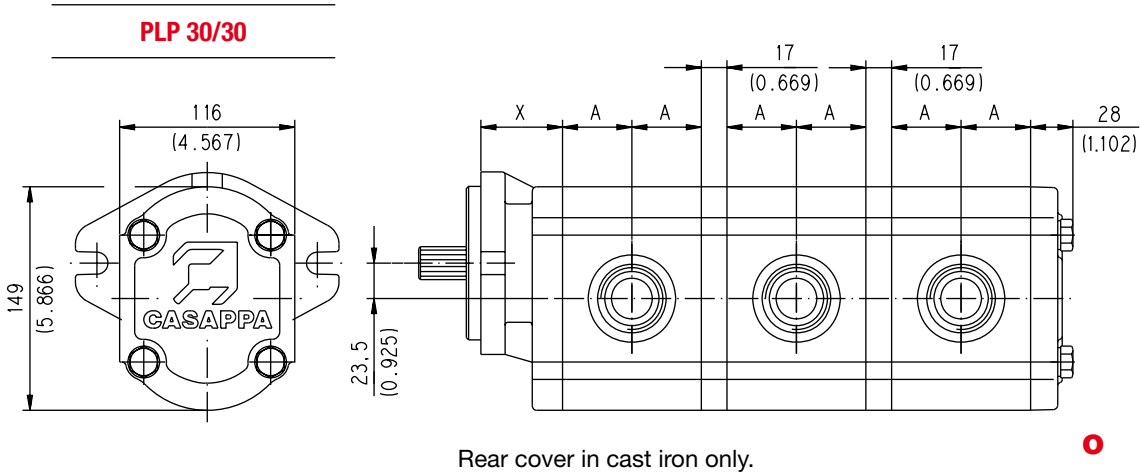

D033-260/0903

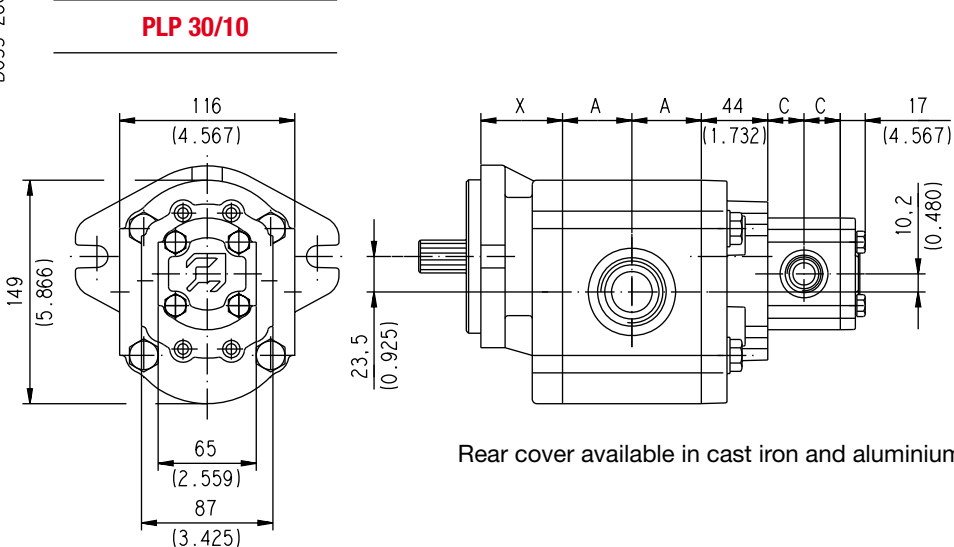

○ 04/10.2020

**POLARIS 30**
**MULTIPLE PUMPS DIMENSIONS**
**PLP30**

Pump type	<b>A</b>
	mm (inch)
<b>PLP 30•22</b>	39 (1.5354)
<b>PLP 30•27</b>	40,5 (1.5945)
<b>PLP 30•34</b>	43 (1.6929)
<b>PLP 30•38</b>	44,5 (1.7520)
<b>PLP 30•43</b>	46 (1.8110)
<b>PLP 30•51</b>	48,5 (1.9094)
<b>PLP 30•61</b>	51,5 (2.0276)
<b>PLP 30•73</b>	55,5 (2.1850)
<b>PLP 30•82</b>	58 (2.2835)
<b>PLP 30•90</b>	61 (2.4016)

Pump type	<b>B</b>
	mm (inch)
<b>PLP 20•4</b>	25,75 (1.0138)
<b>PLP 20•6,3</b>	27 (1.0630)
<b>PLP 20•7,2</b>	27,5 (1.0827)
<b>PLP 20•8</b>	28,25 (1.1122)
<b>PLP 20•9</b>	28,9 (1.1378)
<b>PLP 20•10,5</b>	30,25 (1.1909)
<b>PLP 20•11,2</b>	30,5 (1.2008)
<b>PLP 20•14</b>	33 (1.2992)
<b>PLP 20•16</b>	34,75 (1.3681)
<b>PLP 20•19</b>	36,45 (1.4350)
<b>PLP 20•20</b>	38 (1.4961)
<b>PLP 20•24,5</b>	40,8 (1.6063)
<b>PLP 20•25</b>	42 (1.6535)
<b>PLP 20•27,5</b>	43,35 (1.7067)
<b>PLP 20•31,5</b>	47 (1.8504)

Pump type	<b>C</b>
	mm (inch)
<b>PLP 10•1</b>	17,6 (0.6929)
<b>PLP 10•1,5</b>	18,4 (0.7244)
<b>PLP 10•2</b>	19,2 (0.7559)
<b>PLP 10•2,5</b>	20 (0.7874)
<b>PLP 10•3,15</b>	21 (0.8268)
<b>PLP 10•4</b>	22,4 (0.8819)
<b>PLP 10•5</b>	24 (0.9449)
<b>PLP 10•5,8</b>	25,3 (0.9961)
<b>PLP 10•6,3</b>	26 (1.0236)
<b>PLP 10•8</b>	28,75 (1.1319)
<b>PLP 10•10</b>	32 (1.2598)

02/07.2006

## OUTBOARD BEARING OPTIONS

For each version, the possible combination between drive shafts and mounting flanges are shown on pages 58 ÷ 69.  
For the outboard bearing life expectancy, diagrams providing approximate selection data will be found on subsequent pages.  
For particular applications please consult our pre-sales department.

### PLP 10 - 20 - 30

**VERSION 0**

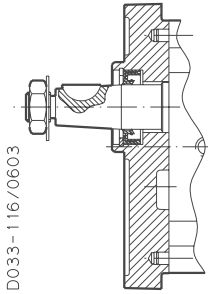

Version for applications without radial and axial load on the drive shaft.

**PLP20 VERSION W8**

Only available in 55 W8

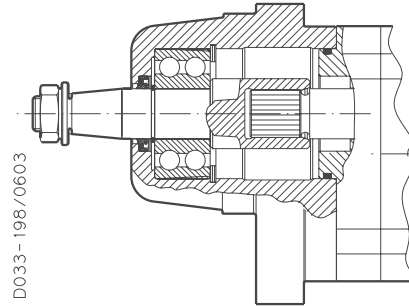

**PLP20 VERSION 5**

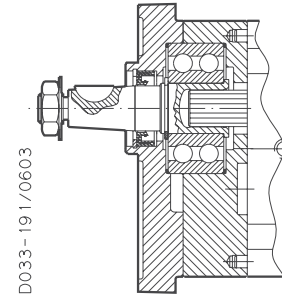

**PLP20 VERSION 7**

Only available in 82 E2

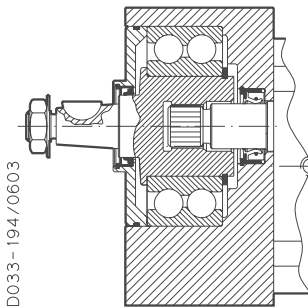

**PLP20 VERSION 8**

Only available in B1 E2

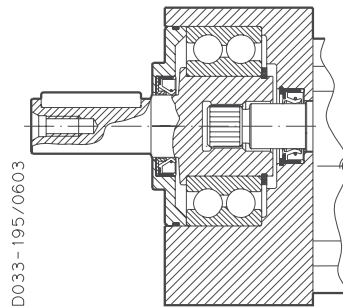

**PLP20 VERSION 9**

Only available in 55 B2

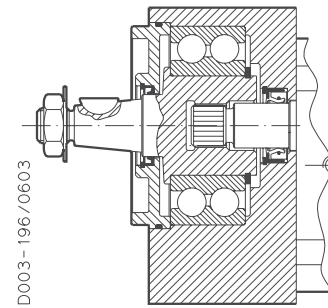

Replaces: 01/09.2019

04/10.2020

**POLARIS 20**

**VERSION WITH OUTBOARD BEARING**

**W8**

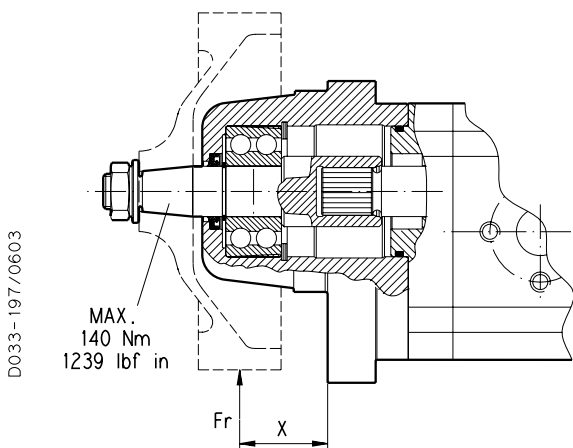

**X** = Distance of the radial load result from the mounting flange [mm (in)].

Each curve has been obtained at:

- Lubricant oil ISO VG 46
- Temperature 60 °C (140 °F)
- Without axial load
- Contamination level according ISO 281:  $\beta_{12}(C) = 200$
- Reliability level of the calculation 90%

**Example**

Fr Radial load	1900 N (427.5 lbf)
X	20 mm (0.79 in)
Speed	2000 min <sup>-1</sup>
Rated fatigue life	≈ 3050 h

Values shown in the diagrams are indicative only. For more information please consult our pre-sales department.

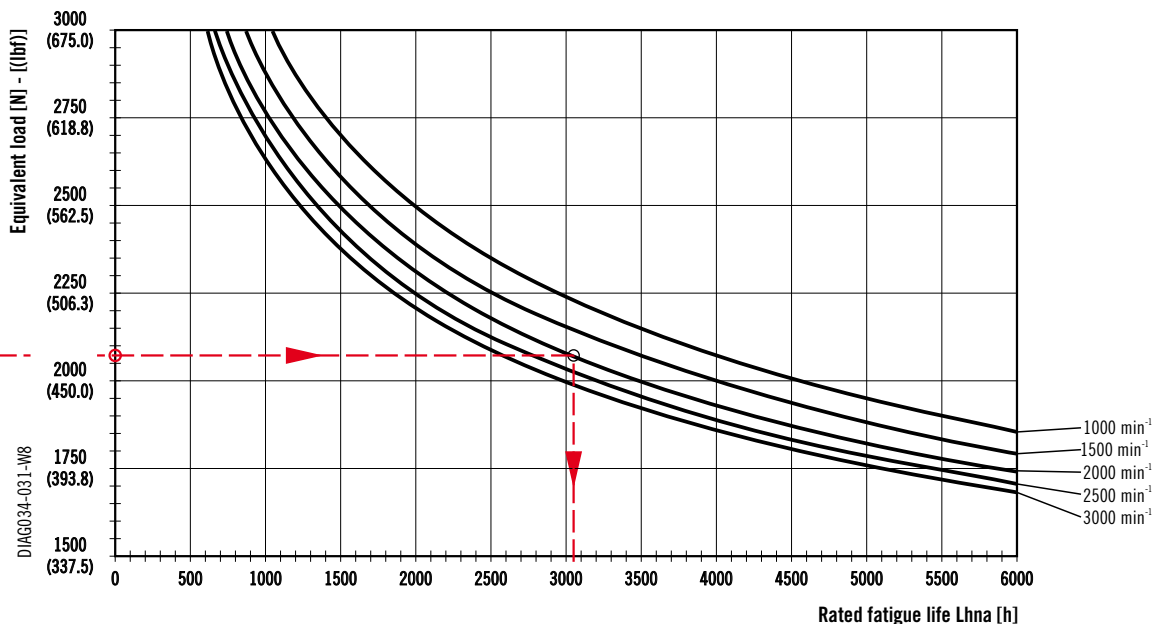
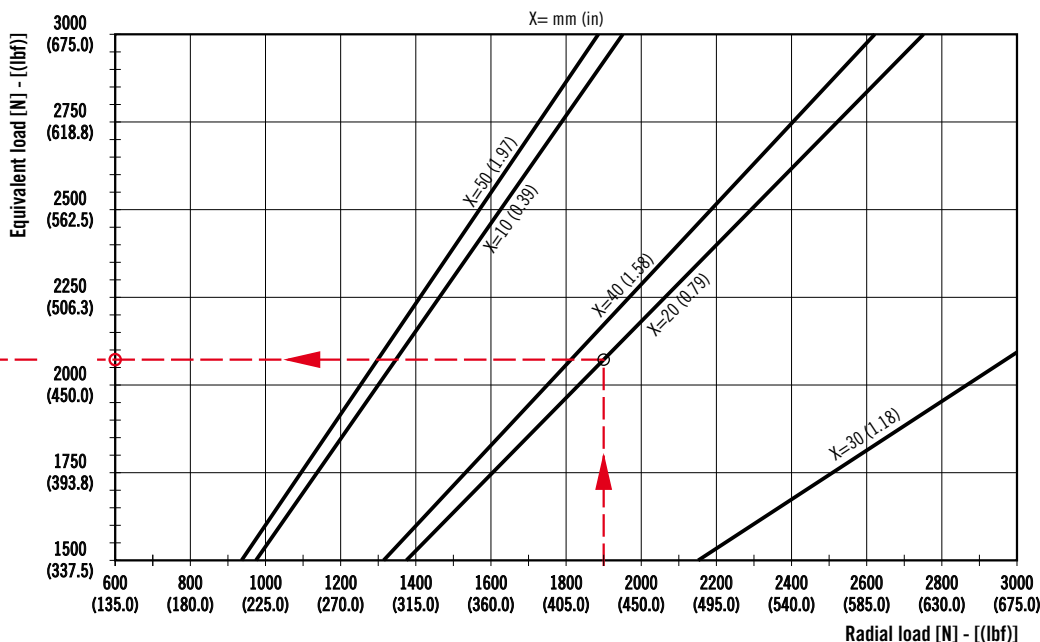

02/07.2006

DIAG034-03-W8

**POLARIS 20**

**VERSION WITH OUTBOARD BEARING**

**5**

D033-115/0603

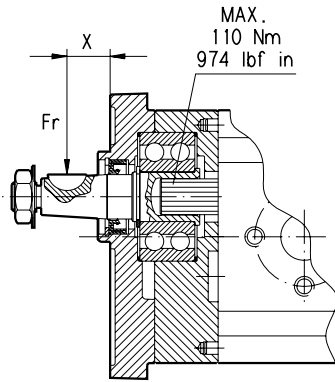

**X** = Distance of the radial load result from the mounting flange [mm (in)].

Each curve has been obtained at:

- Lubricant oil ISO VG 46
- Temperature 60 °C (140 °F)
- Without axial load
- Contamination level according ISO 281:  $\beta_{12}(C) = 200$
- Reliability level of the calculation 90%



**Example**

Fr Radial load	850 N (191.3 lbf)
X	20 mm (0.79 in)
Speed	2000 min <sup>-1</sup>
Rated fatigue life	≈ 2100 h

Values shown in the diagrams are indicative only. For more information please consult our pre-sales department.

Replaces: 02/07.2008

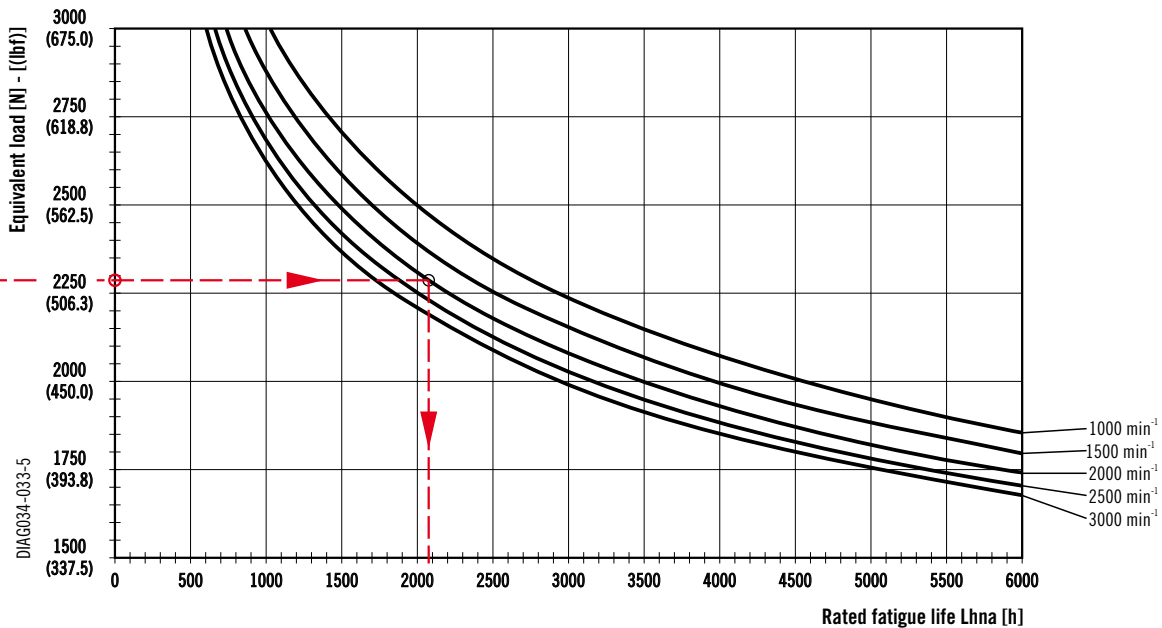
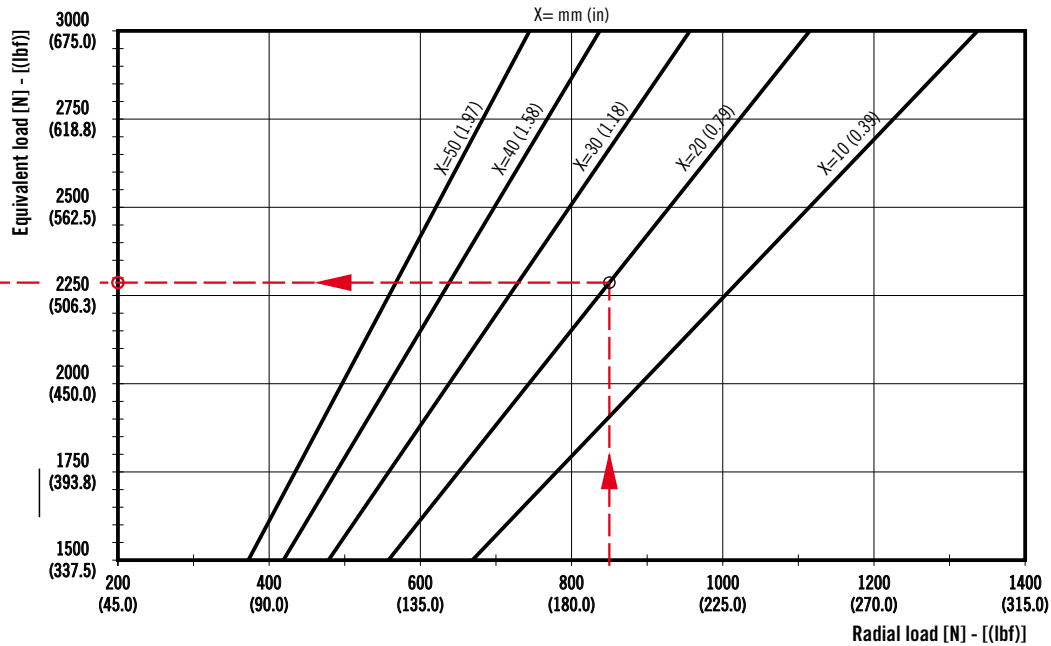

04/10.2020

**POLARIS 20**

**VERSION WITH OUTBOARD BEARING**

**7 - 8 - 9**

Replaces: 02/07.2006

D033-118/0603

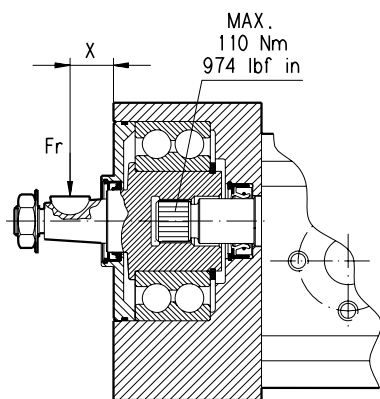

X = Distance of the radial load result from the mounting flange [mm (in)].

Each curve has been obtained at:

- Lubricant oil ISO VG 46
- Temperature 60 °C (140 °F)
- Without axial load
- Contamination level according ISO 281:  $\beta_{12}(C) = 200$
- Reliability level of the calculation 90%

**Example**

Fr Radial load	1900 N (427.5 lbf)
X	20 mm (0.79 in)
Speed	2000 min <sup>-1</sup>
Rated fatigue life	≈ 4600 h

Values shown in the diagrams are indicative only. For more information please consult our pre-sales department.

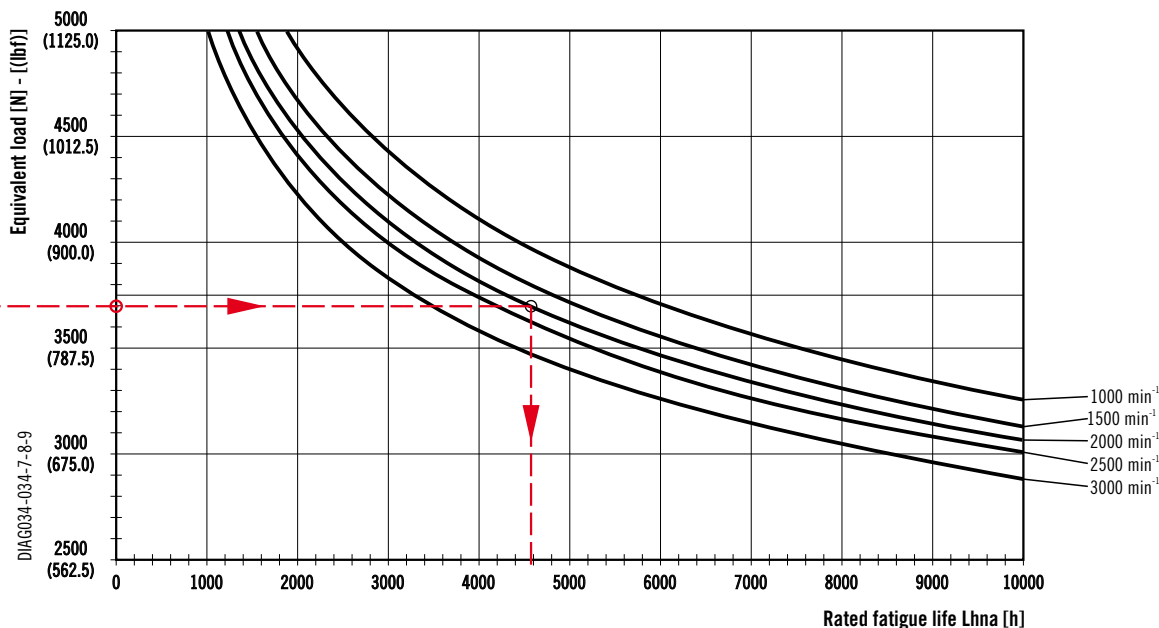
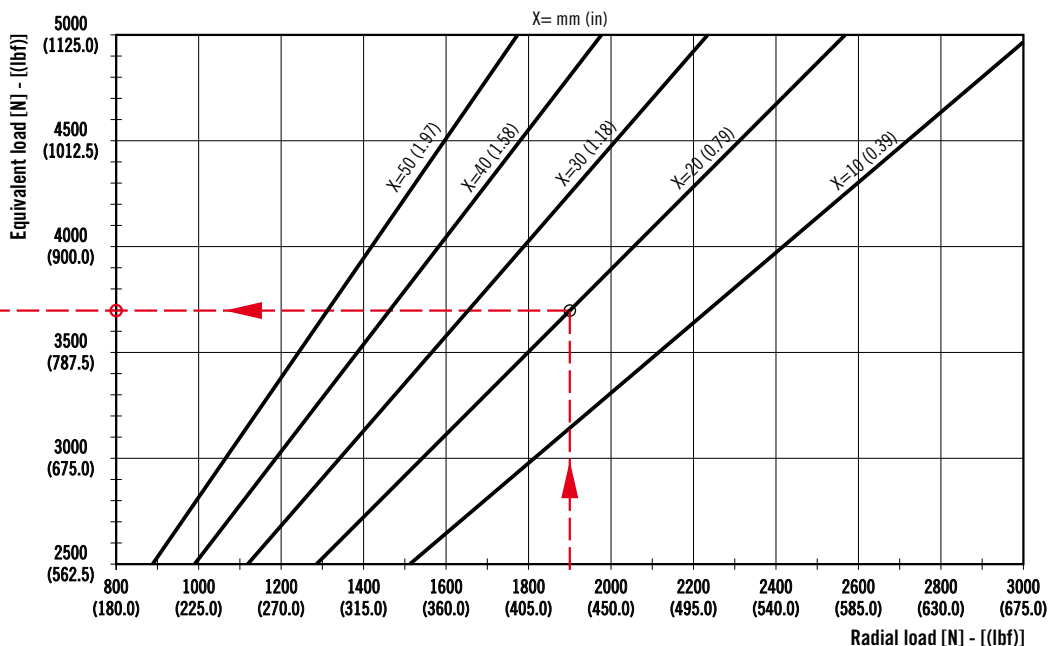

04/10.2020

DIAG034-034-7-8-9



**POLARIS 10**

**DRIVE SHAFTS**

**EUROPEAN TAPERED 1:8**

**81**

Mounting face refer to flange code **E1**

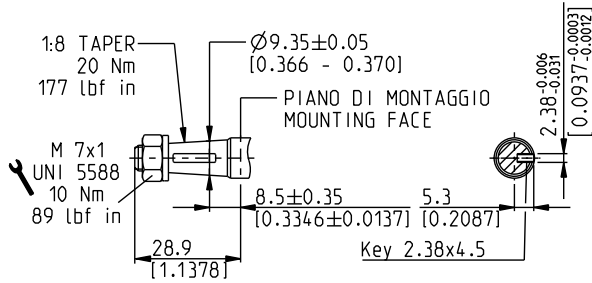

DCAT\_033\_041

**EUROPEAN TAPERED 1:8**

**86**

Mounting face refer to flange code **E7**

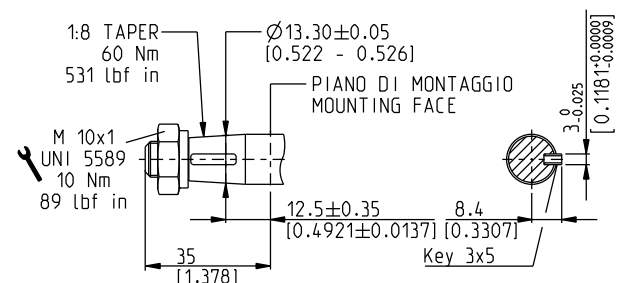

DCAT\_033\_042

Replaces: 01/10.2003

**SAE "AA" SPLINE**

**02**

Mounting face refer to flange code **R9**

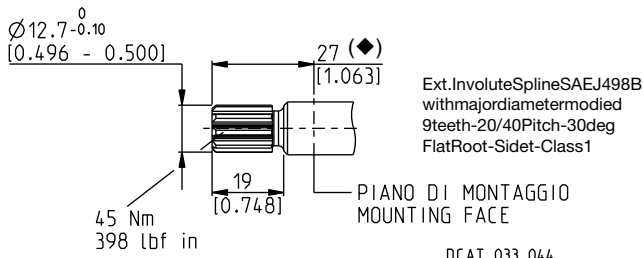

DCAT\_033\_044

(◆) 24 (0.9449) with flange code **S0**

**SAE "AA" STRAIGHT**

**30**

Mounting face refer to flange code **S0**

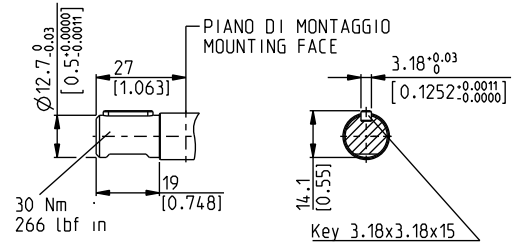

DCAT\_033\_045

**SAE STRAIGHT**

**36**

Not available with size:

**10•1,5    10•2,5**

Mounting face refer to flange code **R8**

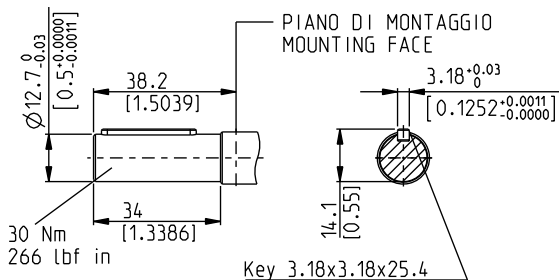

DCAT\_033\_046

**STRAIGHT**

**29**

Not available with size:

**10•5,8**

Mounting face refer to flange code **E8**

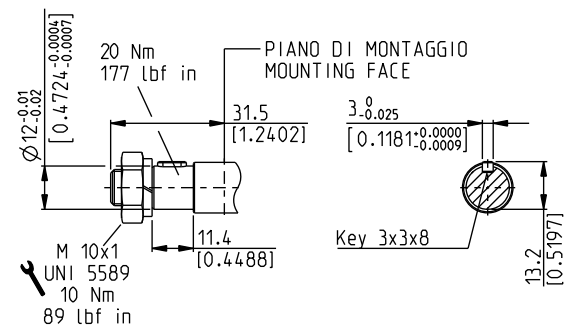

DCAT\_033\_043

Replaces: 04/10.2020

**POLARIS 20**

**DRIVE SHAFTS**

**EUROPEAN TAPERED 1:8**

**82**

Not available with size:

**20•24,5**

Replaces: 01/10.2003

Mounting face refer to flange code **E2**

**○**

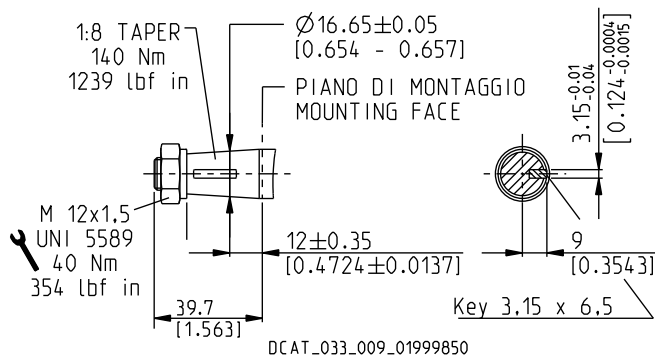

**GERMAN TAPERED 1:5**

**54**

Mounting face refer to flange code **B2**

**○**

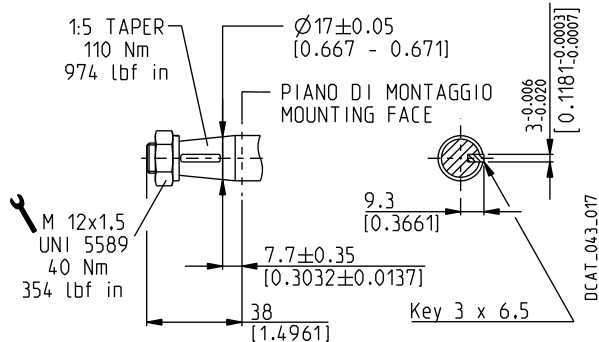

**SAE "A" SPLINE**

**03**

Mounting face refer to flange code **S1**

**○**

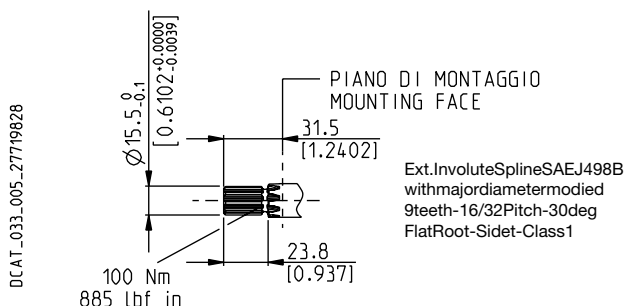

**GERMAN TAPERED 1:5**

**55**

Mounting face refer to flange code **B2**

**○**

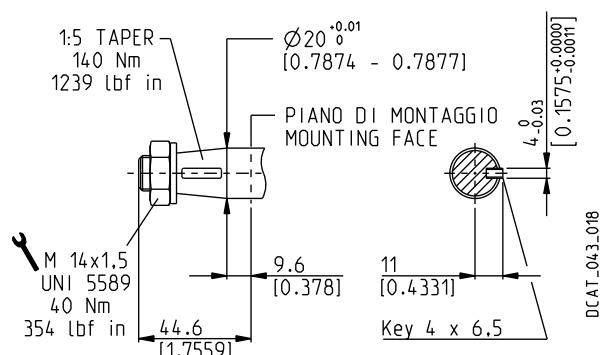

**STRAIGHT**

**46**

Not available with size:

**20•7,2 20•19 20•24,5 20•27,8**

Mounting face refer to flange code **E2**

**○**

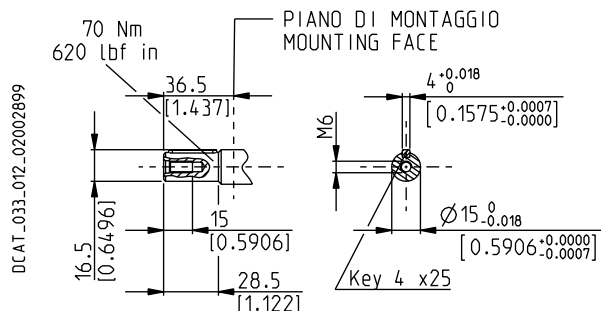

**SPLINE**

**01**

Mounting face refer to flange code **S1**

**○**

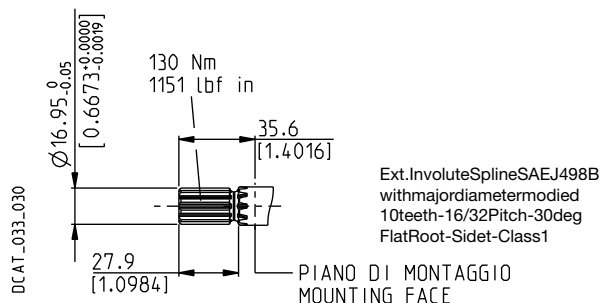

**POLARIS 20**

**DRIVE SHAFTS**

**SAE SPLINE**

**07**

Mounting face refer to flange code **S1**

**○**

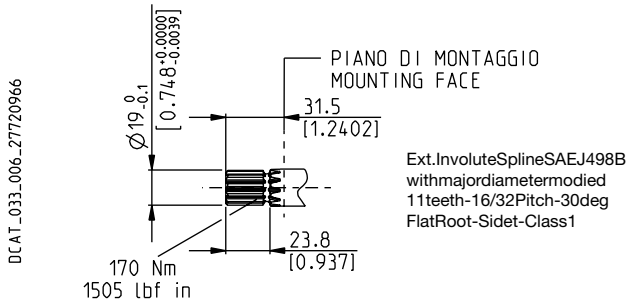

**SAE "A" STRAIGHT**

**31**

Not available with size:

**○**

**20•24,5 20•27,8**

Mounting face refer to flange code **S1**

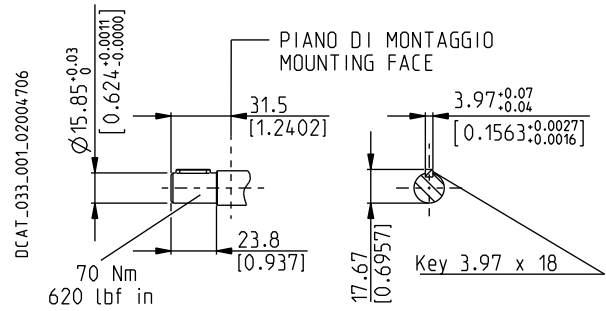

**STRAIGHT**

**49**

Not available with size:

**20•19 20•24,5**

Mounting face refer to flange code **S1**

**○**

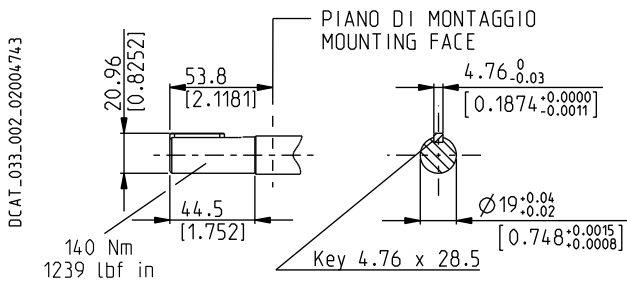

**STRAIGHT**

**50**

Mounting face refer to flange code **S1**

**○**

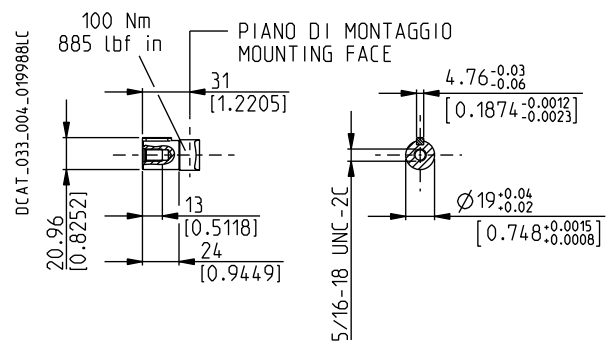

**SAE "B" SPLINE**

**04**

Mounting face refer to flange code **S5**

**○**

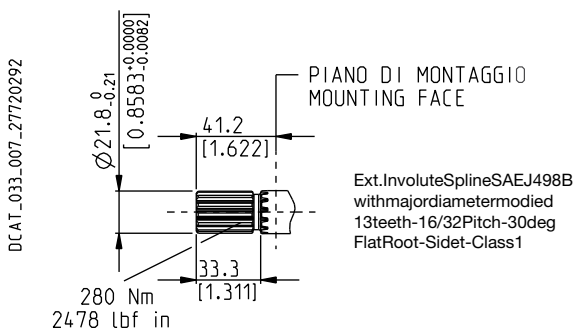

**SAE "B" STRAIGHT**

**32**

Not available with size:

**20•24,5**

Mounting face refer to flange code **S5**

**○**

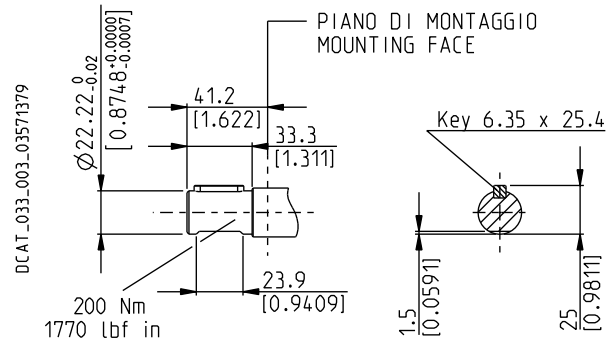

Replaces: 01/10.2003

○ 04/10.2020

**POLARIS 20**

**DRIVE SHAFTS**

**DIN 5482 SPLINE**

**12**

Mounting face refer to flange code **B2**

**○**

Replaces: 01/10.2003

DCAT\_033\_008\_27721460

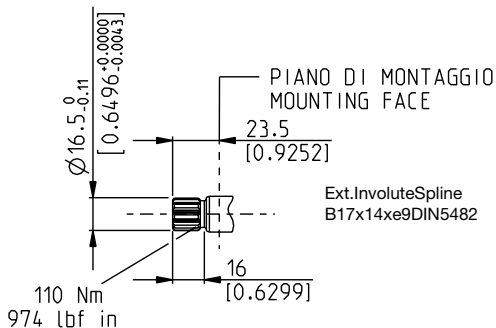

**STRAIGHT**

**B1**

Only for version 5 and 8 with outboard bearing

Mounting face refer to flange code **E2**

DCAT\_033\_032

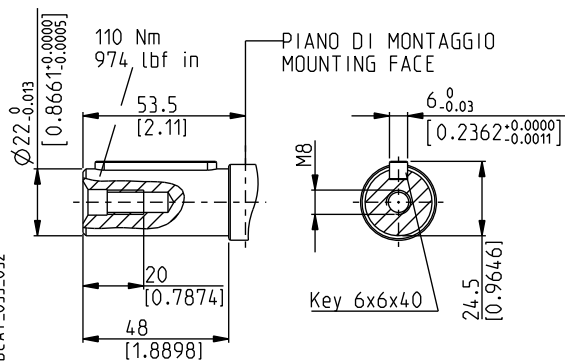

**○** 04/10.2020

**STRAIGHT**

**48**

Only for version 5 with outboard bearing

Available in 0 version only with size:

**20•20**

Mounting face refer to flange code **E2**

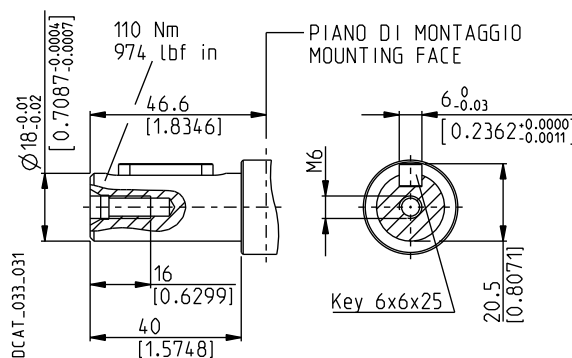

**TANG**

**95**

Not available with size:

**20•19 20•24,5**

Mounting face refer to flange code **B6**

**○**

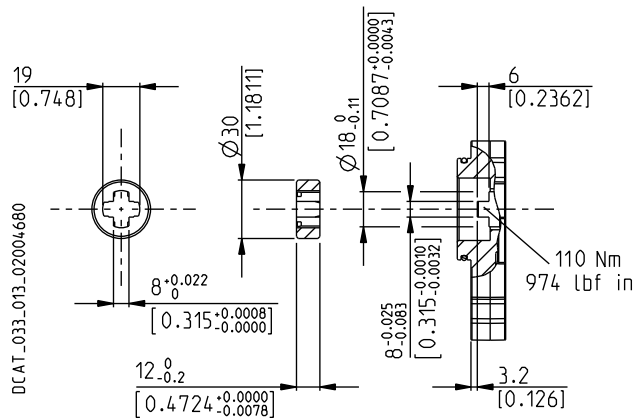

**POLARIS 30**

**DRIVE SHAFTS**

**EUROPEAN TAPERED 1:8**

**83**

Not available with size:

**30•82 30•90**

Mounting face refer to flange code **E3**

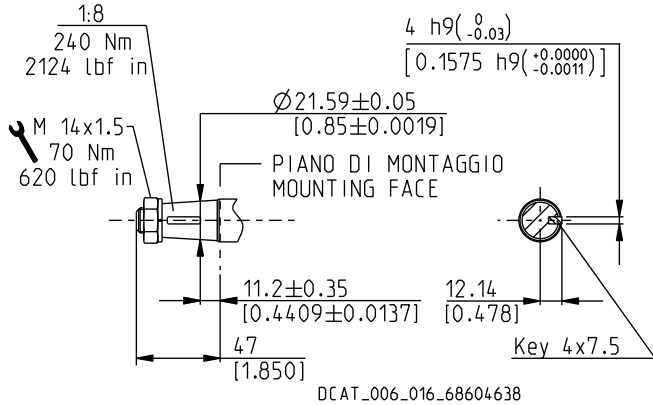

**EUROPEAN TAPERED 1:8**

**84**

Not available with size:

**30•22 30•34**

Mounting face refer to flange code **E4**

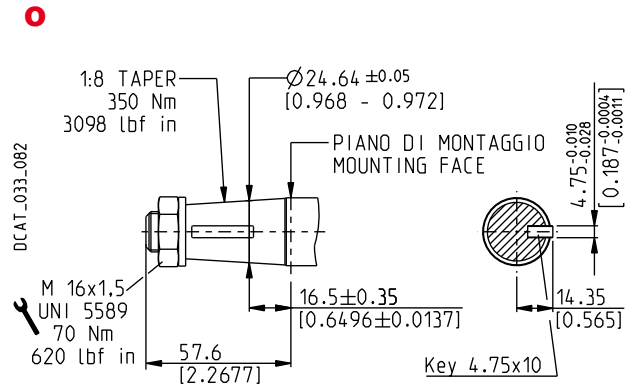

Replaces: 01/10.2003

**GERMAN TAPERED 1:5**

**56**

Not available with size:

**30•61 30•73 30•82 30•90**

Mounting face refer to flange code **B3**

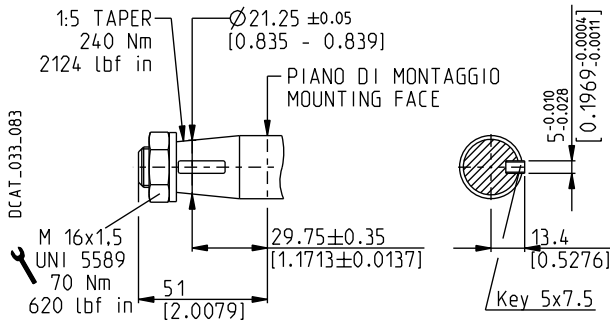

**STRAIGHT**

**41**

Not available with size:

**30•82 30•90**

Mounting face refer to flange code **E3**

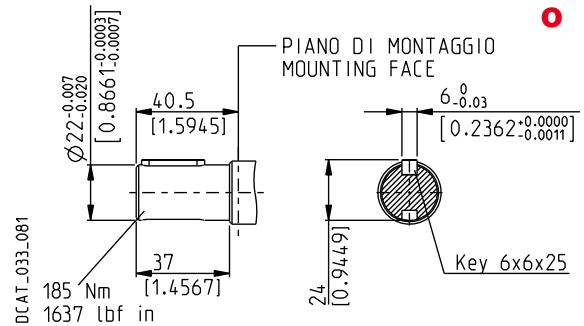

**SAE "B" SPLINE**

**A8**

Not available with size:

**30•82 30•90**

Mounting face refer to flange code **U3**

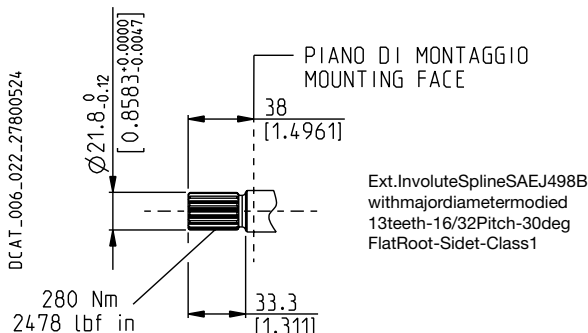

**SAE "BB" SPLINE**

**A5**

Mounting face refer to flange code **U3**

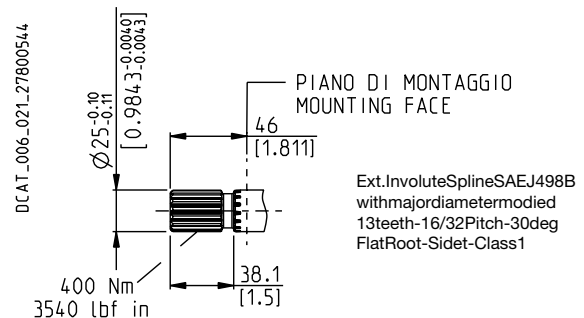

Replaces: 04/10.2020

**POLARIS 30**

**DRIVE SHAFTS**

**SAE "B" SPLINE**

**04**

Mounting face refer to flange code **S5**

Replaces: 01/10.2003

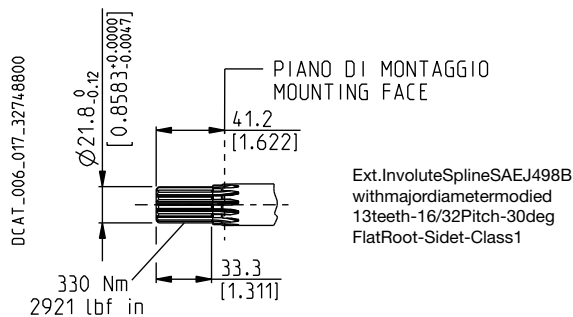

**SAE "BB" SPLINE**

**05**

Mounting face refer to flange code **S5**

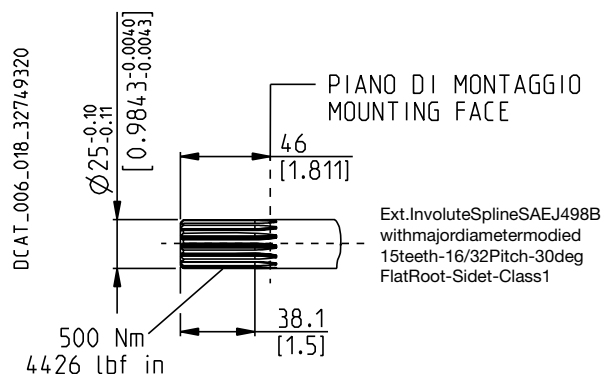

**SAE "B" STRAIGHT**

**32**

Mounting face refer to flange code **S5**

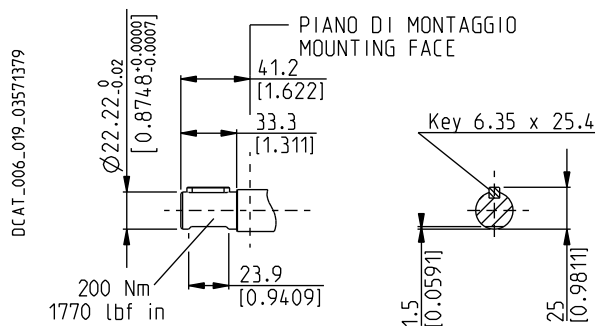

**SAE "BB" STRAIGHT**

**33**

Mounting face refer to flange code **S5**

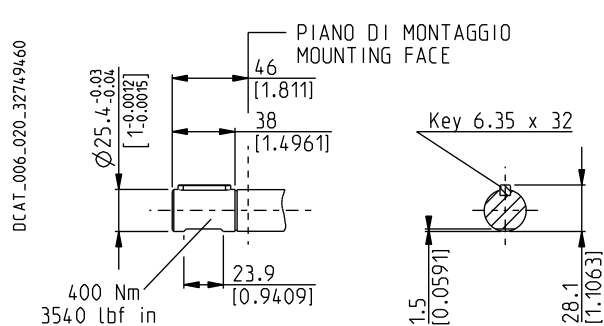

04/10.2020

**POLARIS 10**

**MOUNTING FLANGES AND TABLE OF COMPATIBILITY**

**EUROPEAN**

**E1**

Material: cast iron and aluminium

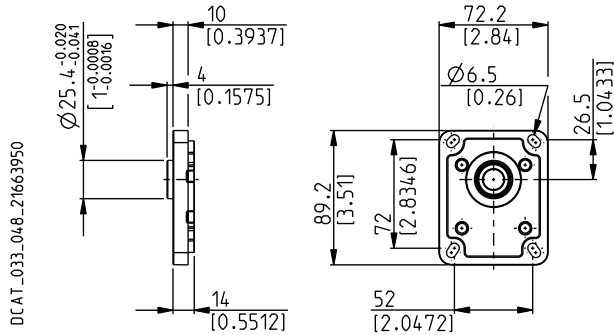

**DRIVE SHAFTS**  
See page 52

**VERSIONS**  
See page 48

**81 02 29 86**

**0 # X X X**

# Standard combination  
X Available combination

**EUROPEAN**

**E7**

Material: cast iron and aluminium

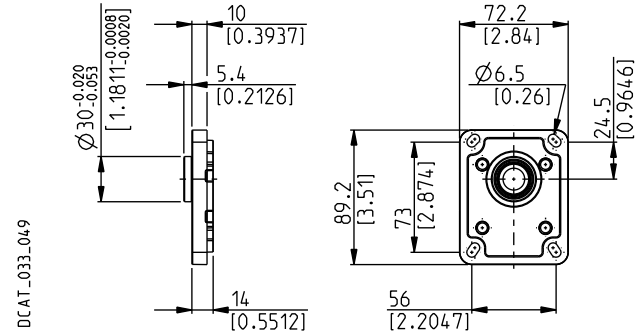

**DRIVE SHAFTS**  
See page 52

**VERSIONS**  
See page 48

**86 29 30**

**0 # X X**

# Standard combination  
X Available combination

**EUROPEAN**

**E8**

Material: cast iron and aluminium

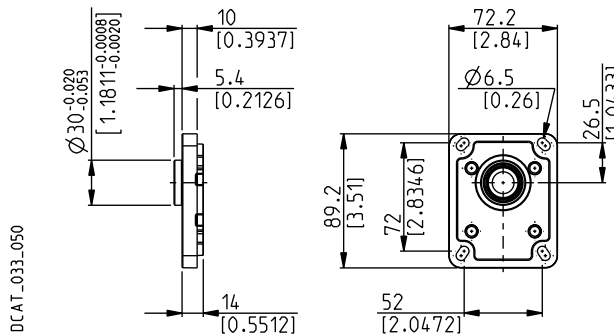

**DRIVE SHAFTS**  
See page 52

**VERSIONS**  
See page 48

**29 02**

**0 # X**

# Standard combination  
X Available combination

**GERMAN 2 BOLTS**

**B1**

Material: aluminium

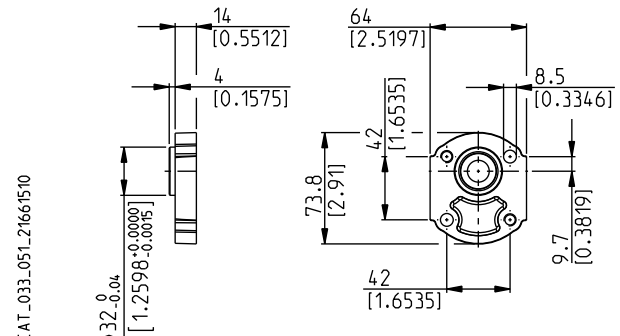

**DRIVE SHAFTS**  
See page 52

**VERSIONS**  
See page 48

**30 86**

**0 # X**

# Standard combination  
X Available combination

02/07.2006

**POLARIS 10**

**MOUNTING FLANGES AND TABLE OF COMPATIBILITY**

**GERMAN 4 BOLTS**

**K2**

Material: aluminium

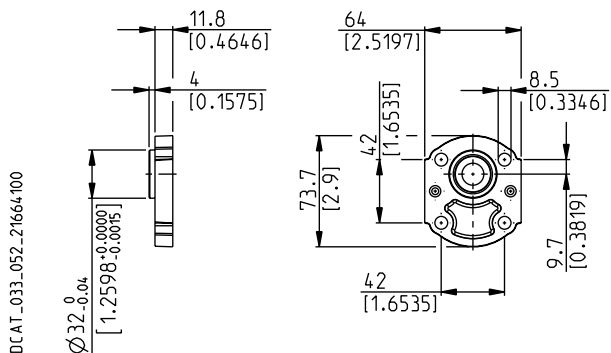

**DRIVE SHAFTS**  
See page 52

VERSIONS	02	30
See page 48		
<b>0</b>	<b>X</b>	<b>X</b>

# Standard combination  
X Available combination

**SAE "A-A" 2 BOLTS**

**S0**

Material: cast iron and aluminium

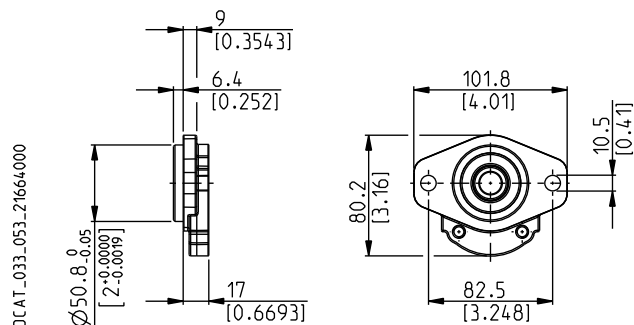

**DRIVE SHAFTS**  
See page 52

VERSIONS	30	02	86
See page 48			
<b>0</b>	<b>#</b>	<b>X</b>	<b>X</b>

# Standard combination  
X Available combination

**SAE "A-A" 2-4 BOLTS**

**R9**

Material: cast iron

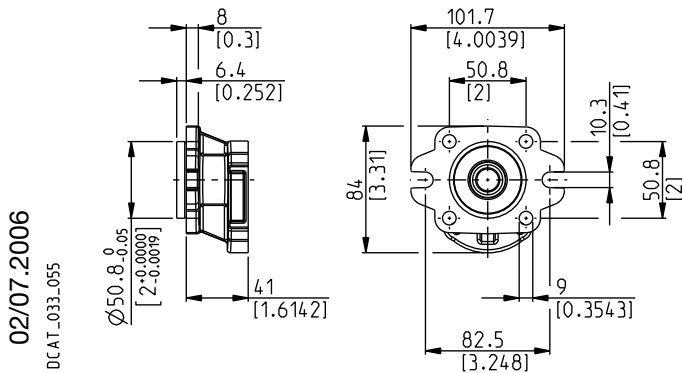

**DRIVE SHAFTS**  
See page 52

VERSIONS	02	30	36
See page 48			
<b>0</b>	<b>#</b>	<b>X</b>	<b>#</b>

# Standard combination  
X Available combination

**SAE 2-4 BOLTS**

**R8**

Material: cast iron

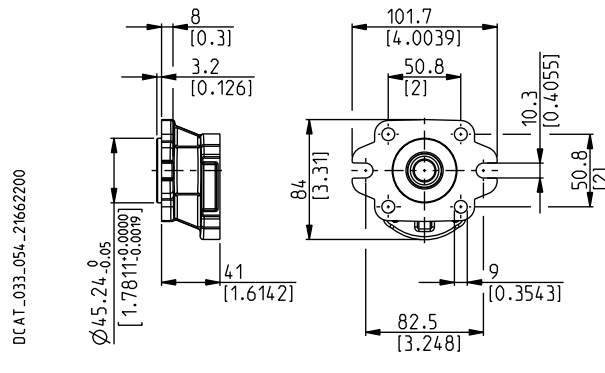

**DRIVE SHAFTS**  
See page 52

VERSIONS	02	30	36
See page 48			
<b>0</b>	<b>#</b>	<b>X</b>	<b>#</b>

# Standard combination  
X Available combination



**POLARIS 10**

**MOUNTING FLANGES AND TABLE OF COMPATIBILITY**

**SAE 2 BOLTS**

**W9**

Material: cast iron

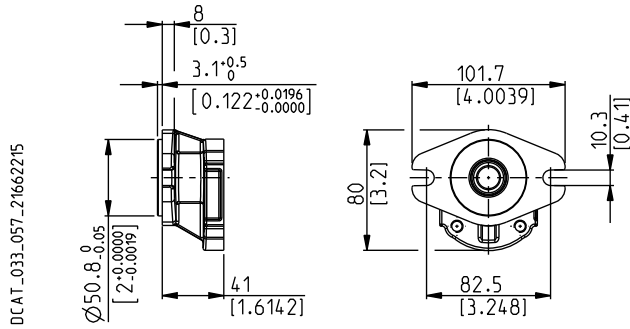

**DRIVE SHAFTS**

See page 52

**VERSIONS**

See page 48

**36**

**0**

**#**

# Standard combination

X Available combination

02/07.2006

**POLARIS 20**

**MOUNTING FLANGES AND TABLE OF COMPATIBILITY**

Replaces: 02/07.2006

**EUROPEAN**

**E2**

Material: cast iron and aluminium

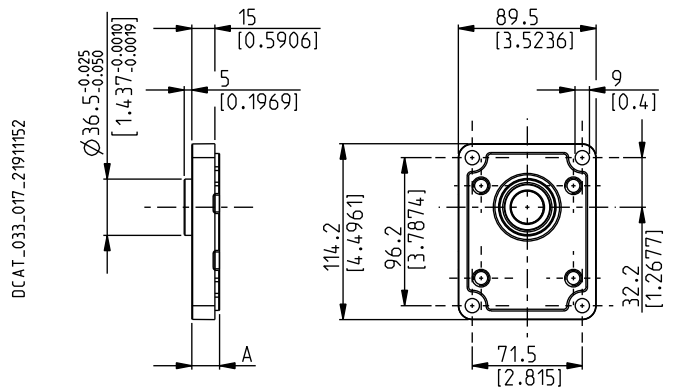

**DRIVE SHAFTS**

See page 53 ÷ 55

VERSIONS See page 48	A mm (in)	82	46	B1	03	04	07	12	31	48	49	50	54
<b>0</b>	18 (0.7087)	#	#		X	X	X	X	X	X	X	X	X
<b>5</b>	43,6 (1.7165)	#		X	X					#	X	X	X
<b>7</b>	59,4 (2.3386)	#											
<b>8</b>	59,4 (2.3386)			#									

# Standard combination

X Available combination

**GERMAN**

**B2**

Material: cast iron and aluminium

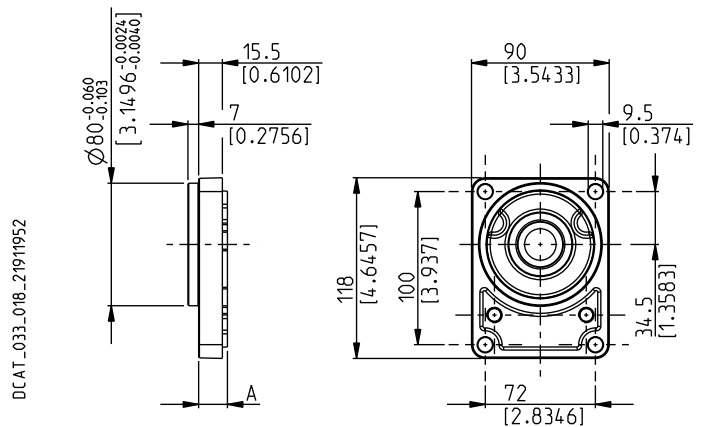

**DRIVE SHAFTS**

See page 53 ÷ 55

VERSIONS See page 48	A mm (in)	12	54	55	01	03	31	46	49	82
<b>0</b>	18,8 (0.7402)	#	#		X	X	X	X	X	X
<b>5</b>	44,4 (1.7480)		X	X		X			X	X
<b>9</b>	59,4 (1.7441)			X						

# Standard combination

X Available combination

04/10.2020

**POLARIS 20**

**MOUNTING FLANGES AND TABLE OF COMPATIBILITY**

**GERMAN 2 BOLTS**

**B4**

Material: cast iron and aluminium

⊕ Through hole

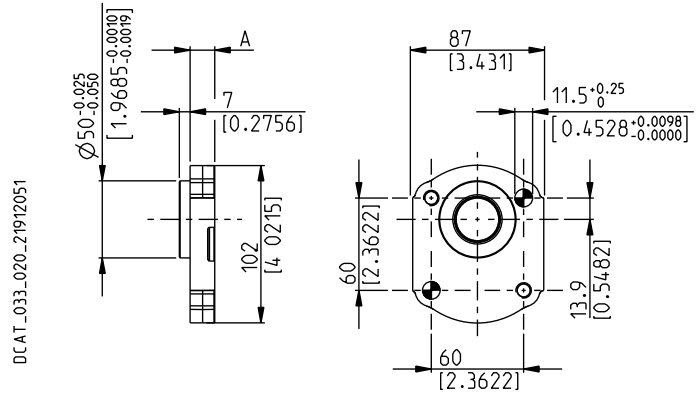

**DRIVE SHAFTS**

See page 53 ÷ 55

VERSIONS See page 48	A mm (in)	54	03	12	31	49	82
0	16 (0.63)	#	x	x	x	x	x
5	41,6 (1.6378)	x	x			x	x

# Standard combination

x Available combination

**GERMAN 2 BOLTS**

**B5**

Material: cast iron and aluminium

⊕ Through hole

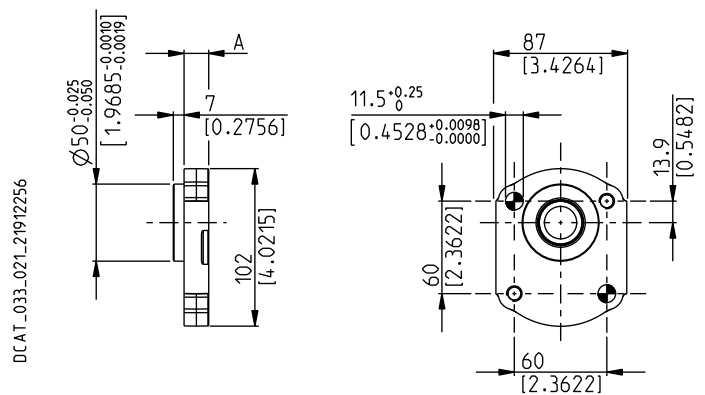

**DRIVE SHAFTS**

See page 53 ÷ 55

VERSIONS See page 48	A mm (in)	54	03	12	31	49	82
0	16 (0.63)	#	x	x	x	x	x
5	41,6 (1.6378)	x	x			x	x

# Standard combination

x Available combination

02/07.2006

**POLARIS 20**

**MOUNTING FLANGES AND TABLE OF COMPATIBILITY**

Replaces: 02/07.2006

**GERMAN 2 BOLTS**

**U2**

Material: cast iron and aluminium

**0**

⊕ Through hole

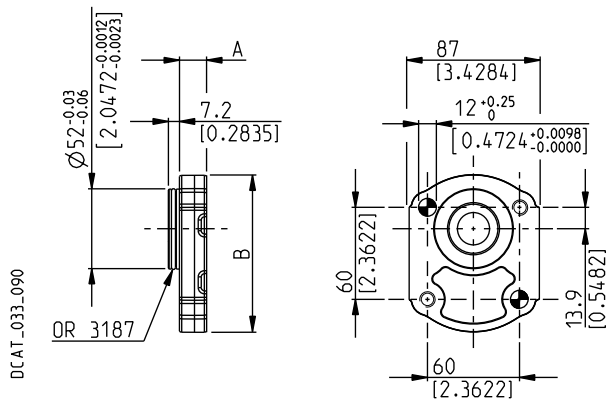

**DRIVE SHAFTS**

See page 54 ÷ 55

VERSIONS	A	B	03	54	07
See page 48	mm (in)	mm (in)			
<b>0</b>	17,7 (0.6968)	⊕ 102 (4.0157)	#		x
<b>5</b>	43,3 (1.747)	● 105 (4.1339)		x	

# Standard combination

⊕ Aluminium

x Available combination

● Cast iron

**0** 04/10.2020

**GERMAN 4 BOLTS**

**B6**

Material: cast iron and aluminium

⊕ Through hole

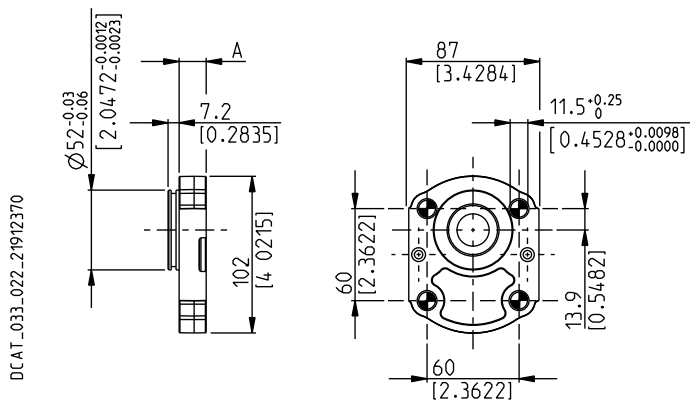

**DRIVE SHAFTS**

See page 54 ÷ 55

VERSIONS	A	95	07	12
See page 48	mm (in)			
<b>0</b>	17,7 (0.6968)	#	x	x
<b>5</b>	43,3 (1.747)	x		

# Standard combination

x Available combination

**POLARIS 20**

**MOUNTING FLANGES AND TABLE OF COMPATIBILITY**

**SAE "A" 2 BOLTS**

**S1**

Material: cast iron and aluminium

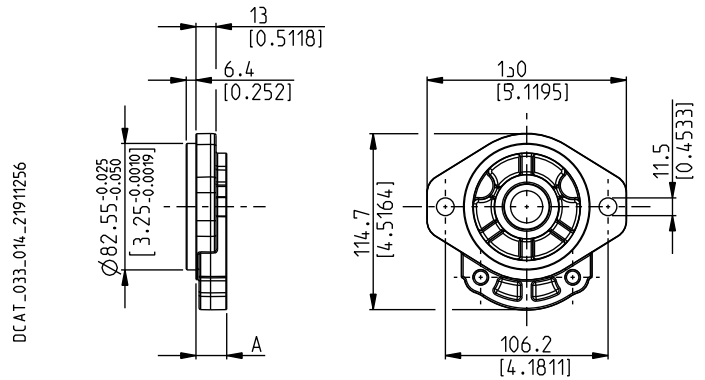

**DRIVE SHAFTS**

See page 53 ÷ 55

VERSIONS See page 48	A mm (in)	01	03	04	07	12	31	32	46	49	50	54	82
<b>0</b>	20 (0.787)	#	#	X	#	X	#	X	X	#	X	X	X
<b>5</b>	45,6 (1.7953)		X							X	X	X	X

# Standard combination

X Available combination

**SAE "A" 2 BOLTS**

**S2**

Material: cast iron and aluminium

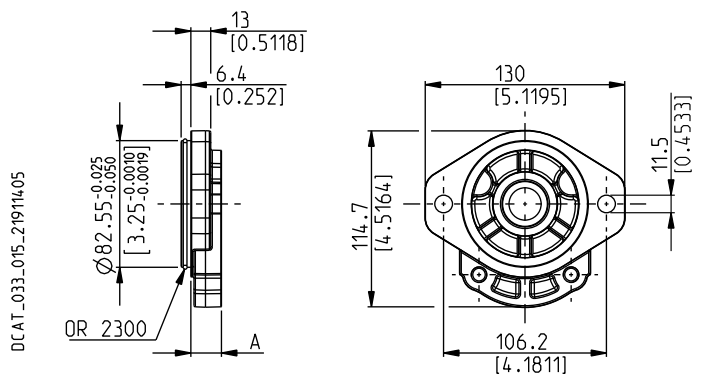

**DRIVE SHAFTS**

See page 53 ÷ 55

VERSIONS See page 48	A mm (in)	01	03	04	07	12	31	32	46	49	50	54	82
<b>0</b>	20 (0.7874)	#	#	X	#	X	#	X	X	#	X	X	X
<b>5</b>	45,6 (1.7953)		X							X	X	X	X

# Standard combination

X Available combination

02/07.2006

**POLARIS 20**

**MOUNTING FLANGES AND TABLE OF COMPATIBILITY**

**SAE "A" 2 BOLTS**

**S9**

Material: cast iron and aluminium

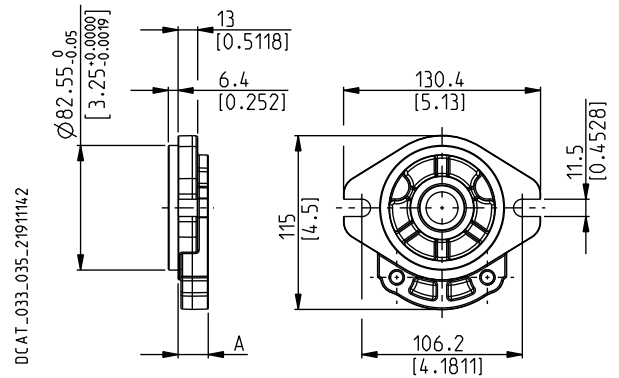

**DRIVE SHAFTS**

See page 53 ÷ 55

VERSIONS See page 48	A mm (in)	01	03	04	07	12	31	32	46	49	50	54	82
<b>0</b>	20 (0.7874)	#	#	X	#	X	#	X	X	#	X	X	X
<b>5</b>	45,6 (1.7953)		X							X	X	X	X

# Standard combination

X Available combination

**SAE "B" 2 BOLTS**

**S5**

Material: cast iron

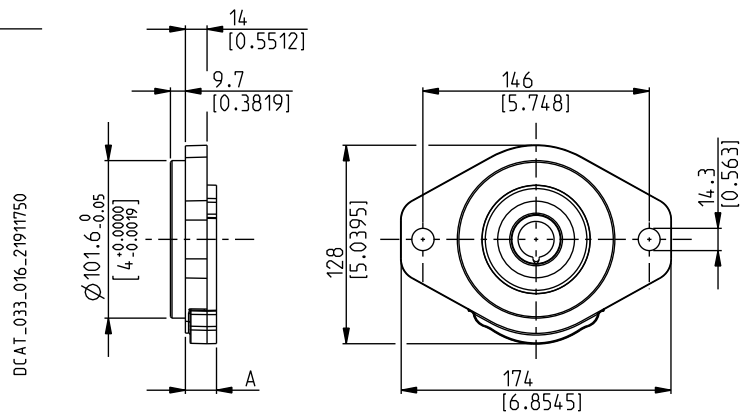

**DRIVE SHAFTS**

See page 54

VERSIONS See page 48	A mm (in)	04	32	49
<b>0</b>	20 (0.7874)	#	#	X
<b>5</b>	45,6 (1.7953)			X

# Standard combination

X Available combination

02/07.2006

**POLARIS 20**

**MOUNTING FLANGES AND TABLE OF COMPATIBILITY**

**GERMAN**

**W8**

Material: cast iron

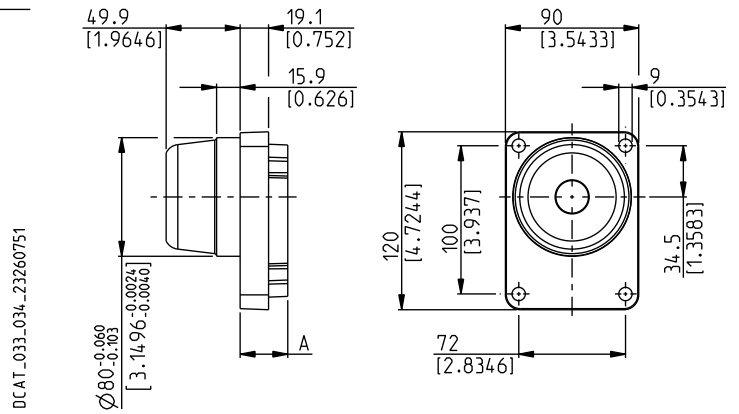

**DRIVE SHAFTS**

See page 53

**VERSIONS**  
See page 48

**A**  
mm (in)

**55**

**W8**

32,1 (1.2638)

**#**

# Standard combination

X Available combination

02/07.2006

**POLARIS 30**

**MOUNTING FLANGES AND TABLE OF COMPATIBILITY**

**EUROPEAN**

**E3**

Material: cast iron

D033-199/0706

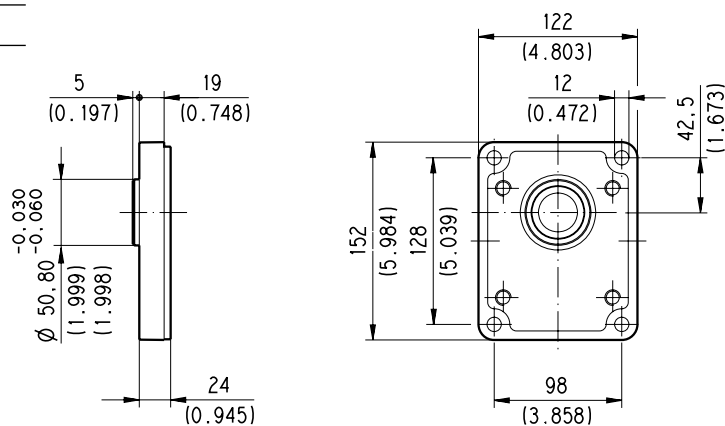

**DRIVE SHAFTS**

See page 56 ÷ 57

VERSIONS See page 48	<b>83</b>	<b>41</b>	<b>04</b>	<b>05</b>	<b>32</b>	<b>33</b>	<b>A5</b>	<b>A8</b>
<b>0</b>	#	#	X	X	X	X	X	X

# Standard combination

X Available combination

**EUROPEAN**

**E4**

Material: cast iron

D033-200/0703

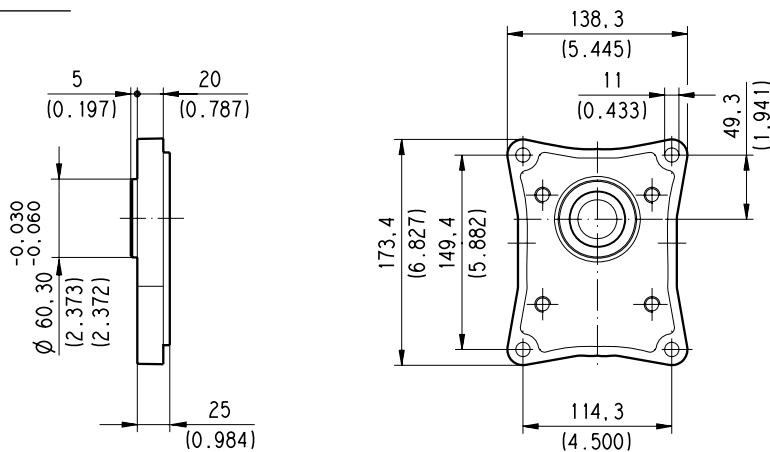

**DRIVE SHAFTS**

See page 56

VERSIONS See page 48	<b>84</b>	<b>41</b>	<b>A5</b>	<b>A8</b>
<b>0</b>	#	X	X	X

# Standard combination

X Available combination

02/07.2006



**POLARIS 30**

**MOUNTING FLANGES AND TABLE OF COMPATIBILITY**

**GERMAN**

**B3**

Material: cast iron

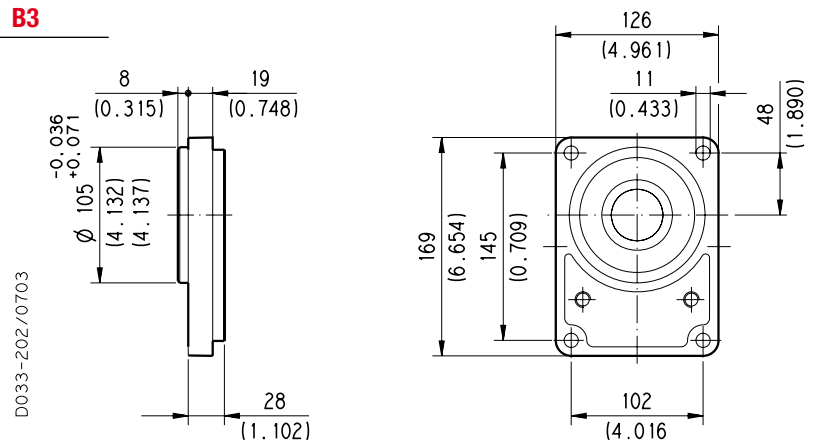

**DRIVE SHAFTS**  
See page 56

VERSIONS See page 48	<b>56</b>	<b>83</b>	<b>A5</b>	<b>A8</b>
<b>0</b>	#	X	X	X

# Standard combination

X Available combination

**SAE "B" 2 BOLTS**

**S5**

Material: cast iron

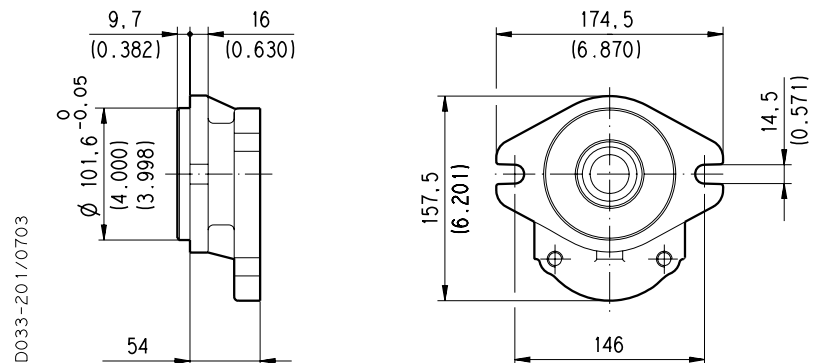

**DRIVE SHAFTS**  
See page 57

VERSIONS See page 48	<b>04</b>	<b>05</b>	<b>32</b>	<b>33</b>
<b>0</b>	#	#	#	#

# Standard combination

X Available combination

02/07.2006

**POLARIS 30**

**MOUNTING FLANGES AND TABLE OF COMPATIBILITY**

**SAE "B" 2 BOLTS**

**U3**

Material: cast iron

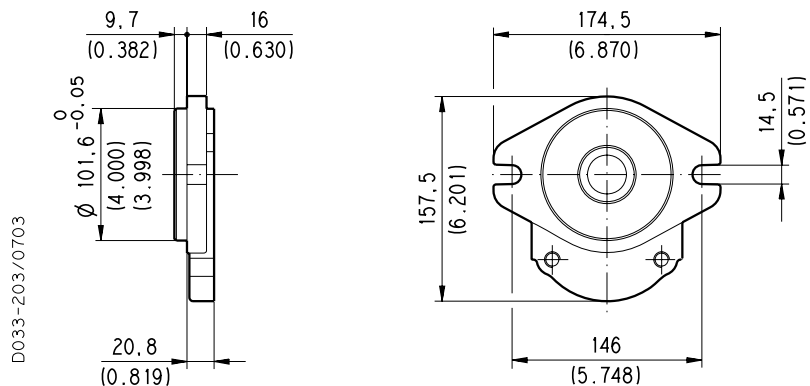

**DRIVE SHAFTS**  
See page 56

<b>VERSIONS</b> See page 48	<b>A5</b>	<b>A8</b>	<b>83</b>
<b>0</b>	<b>#</b>	<b>#</b>	<b>X</b>

# Standard combination

X Available combination

02/07.2006

## PORTS POSITION AND TYPE

PORTS TYPE	SIDE PORTS												REAR PORTS			
	German		European		Split SSM		Spit SSS		Gas BSPP		SAE ODT		Gas BSPP		SAE ODT	
Pump type	IN	OUT	IN	OUT	IN	OUT	IN	OUT	IN	OUT	IN	OUT	IN	OUT	IN	OUT
Motor type	OUT	IN	OUT	IN	OUT	IN	OUT	IN	OUT	IN	OUT	IN	OUT	IN	OUT	IN
<b>PL. 10•1</b>	BB	BA							GC	GC	OB	OA	GC	GC	OB	OA
<b>PL. 10•1,5</b>	BB	BA							GC	GC	OB	OA	GC	GC	OB	OA
<b>PL. 10•2</b>	BB	BA							GC	GC	OB	OA	GC	GC	OB	OA
<b>PL. 10•2,5</b>	BB	BA							GC	GC	OB	OA	GC	GC	OB	OA
<b>PL. 10•3,15</b>	BB	BA							GC	GC	OB	OA	GC	GC	OB	OA
<b>PL. 10•4</b>	BB	BA							GC	GC	OB	OA	GC	GC	OB	OA
<b>PL. 10•5</b>	BB	BA							GD	GD	OB	OA	GD	GD	OB	OA
<b>PL. 10•5,8</b>	BB	BA							GD	GD	OB	OA	GD	GD	OB	OA
<b>PL. 10•6,3</b>	BB	BA							GD	GD	OB	OA	GD	GD	OB	OA
<b>PL. 10•8</b>	BB	BA							GD	GD	OC	OB	GD	GD	OB	OB
<b>PL. 10•10</b>	BB	BA							GD	GD	OC	OB	GD	GD	OB	OB
<b>PL. 20•4</b>	BE	BC	EA	EA	MA	MA	SA	SA	GD	GD	OC	OC	GD	GD	OC	OC
<b>PL. 20•6,3</b>	BE	BC	EA	EA	MA	MA	SA	SA	GD	GD	OC	OC	GD	GD	OC	OC
<b>PL. 20•7,2</b>	BE	BC	EA	EA	MA	MA	SA	SA	GD	GD	OC	OC	GD	GD	OC	OC
<b>PL. 20•8</b>	BE	BC	EA	EA	MA	MA	SA	SA	GD	GD	OC	OC	GD	GD	OC	OC
<b>PL. 20•9</b>	BE	BC	EA	EA	MA	MA	SA	SA	GD	GD	OC	OC	GD	GD	OC	OC
<b>PL. 20•10,5</b>	BE	BC	EA	EA	MA	MA	SA	SA	GD	GD	OC	OC	GD	GD	OC	OC
<b>PL. 20•11,2</b>	BE	BC	EA	EA	MA	MA	SA	SA	GD	GD	OC	OC	GD	GD	OC	OC
<b>PL. 20•14</b>	BE	BC	EB	EA	MB	MA	SB	SA	GE	GD	OD	OC	GE	GD	OD	OC
<b>PL. 20•16</b>	BE	BC	EB	EA	MB	MA	SB	SA	GE	GD	OD	OC	GE	GD	OD	OC
<b>PL. 20•19</b>	BE	BC	EB	EA	MB	MA	SB	SA	GE	GD	OD	OC	GE	GD	OD	OC
<b>PL. 20•20</b>	BE	BC	EB	EA	MB	MA	SB	SA	GE	GD	OD	OC	GE	GD	OD	OC
<b>PL. 20•24,5</b>	BE	BC	EB	EA	MC	MB	SC	SB	GE	GD	OD	OC	GE	GD	OD	OC
<b>PL. 20•25</b>	BE	BC	EB	EA	MC	MB	SC	SB	GE	GD	OD	OC	GE	GD	OD	OC
<b>PL. 20•27,8</b>	BE	BC	EB	EA	MC	MB	SC	SB	GE	GD	OD	OC	GE	GD	OD	OC
<b>PL. 20•31,5</b>	BE	BC	EB	EA	MC	MB	SC	SB	GE	GD	OD	OC	GE	GD	OD	OC
<b>PL. 30•22</b>	BM	BL	ED	EB	MB	MA	SB	SA	GF	GF	OF	OD				
<b>PL. 30•27</b>	BM	BL	ED	EB	MC	MB	SC	SB	GF	GF	OF	OD				
<b>PL. 30•34</b>	BM	BL	ED	EB	MC	MB	SC	SB	GF	GF	OF	OD				
<b>PL. 30•38</b>	BM	BL	ED	EB	MD	MC	SD	SC	GF	GF	OG	OF				
<b>PL. 30•43</b>	BM	BL	ED	EB	MD	MC	SD	SC	GF	GF	OG	OF				
<b>PL. 30•51</b>	BM	BL	ED	EB	MD	MC	SD	SC	GF	GF	OG	OF				
<b>PL. 30•61</b>	BM	BL	ED	EB	ME	MD	SE	SD	GG	GF	OH	OG				
<b>PL. 30•73</b>	BM	BL	EF	ED	ME	MD	SE	SD	GG	GF	OH	OG				
<b>PL. 30•82</b>	BM	BL	EF	ED	ME	MD	SE	SD	GH	GG	OH	OG				
<b>PL. 30•90</b>	BM	BL	EF	ED	MF	ME	SF	SE	GH	GG	OH	OG				

01/10.2003

## EXTERNAL DRAIN PORTS

IN/OUT PORTS TYPE	SIDE PORTS						REAR PORTS	
	German	European	Split SSM	Spit SSS	Gas BSPP	SAE ODT	Gas BSPP	SAE ODT
<b>PL. 10</b>	GA	-	-	-	GA	03	GA	03
<b>PL. 20</b>	TA	GB	GB	03	GB	03	GB	03
<b>PL. 30</b>	GC	GC	GC	OA	GC	OA	-	-

## DRAIN PORTS SIZES

 Tightening torque for low pressure side port

### GAS STRAIGHT THREAD PORTS

**BSPP**

British standard pipe parallel (55°) conforms to UNI - ISO 228

CODE	NOMINAL SIZE	A	Ø B	Ø C	D	E	Nm (lbf in)
			mm (in)	mm (in)	mm (in)	mm (in)	
<b>GA</b>	1/8"	G 1/8	16,5 (0.6496)	8,75 (0.3444)	12 (0.4724)	1 (0.0394)	5 <sup>+0,25</sup> (44 ÷ 46)
<b>GB</b>	1/4"	G 1/4	21,5 (0.8465)	12 (0.4724)	15 (0.5906)	1,5 (0.0591)	15 <sup>+1</sup> (133 ÷ 142)

DCAT\_006\_026\_21064779

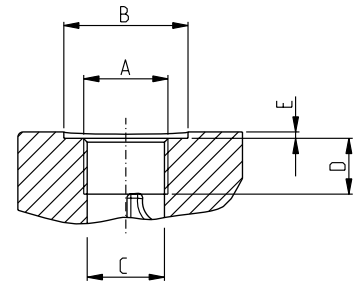

### METRIC STRAIGHT THREAD PORTS ISO 6149

**METRIC**

Metric thread ISO 60° conforms to ISO/R 262

CODE	A	Ø B	Ø C	D	E	Nm (lbf in)
		mm (in)	mm (in)	mm (in)	mm (in)	
<b>TA</b>	M 10x1	22 (0.8661)	9 (0.3543)	13 (0.5118)	0,5 (0.0197)	10 <sup>+0,5</sup> (89 ÷ 93)

DCAT\_006\_027\_21060524

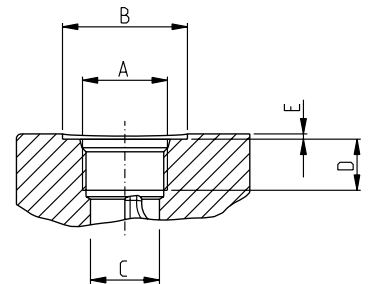

### SAE STRAIGHT THREAD PORTS J514

**ODT**

American straight UNC-UNF 60° conforms to ANSI B 1.1

CODE	A	Ø B	Ø C	D	E	Nm (lbf in)
		mm (in)	mm (in)	mm (in)	mm (in)	
<b>03</b>	7/16"-20 UNF-2B	21 (0.8267)	9,5 (0.3740)	14 (0.5512)	1 (0.0394)	12 <sup>+1</sup> (106 ÷ 115)

Other drain ports are shown on subsequent pages.

01/10.2003

## PORTS SIZE



Tightening torque for low pressure side port



Tightening torque for high pressure side port [values obtained at 5075 psi (350 bar)]

For reversible rotation, please consult only the tightening torque for high pressure side port

### GERMAN FLANGED PORTS - 4 Bolts

**GERMAN**

Metric thread ISO 60° conforms to ISO/R 262

CODE	A	B	C		
	mm (in)	mm (in)	Thread Depth mm (in)	Nm (lbf in)	Nm (lbf in)
<b>BA</b>	8 (0.3150)	30 (1.1811)	M6 12 (0.4724)	8 <sup>+0,5</sup> (71 ÷ 75)	8 <sup>+0,5</sup> (71 ÷ 75)
<b>BB</b>	13 (0.5118)	30 (1.1811)	M6 12 (0.4724)	8 <sup>+0,5</sup> (71 ÷ 75)	8 <sup>+0,5</sup> (71 ÷ 75)
<b>BC</b>	15 (0.5906)	35 (1.3780)	M6 12 (0.4724)	8 <sup>+0,5</sup> (71 ÷ 75)	8 <sup>+0,5</sup> (71 ÷ 75)
<b>BE</b>	20 (0.7874)	40 (1.5748)	M6 12 (0.4724)	8 <sup>+0,5</sup> (71 ÷ 75)	8 <sup>+0,5</sup> (71 ÷ 75)
<b>BL</b>	19 (0.7480)	55 (2.1654)	M8 18 (0.7087)	15 <sup>+1</sup> (133 ÷ 142)	20 <sup>+1</sup> (177 ÷ 186)
<b>BM</b>	27 (1.0630)	55 (2.1654)	M8 18 (0.7087)	15 <sup>+1</sup> (133 ÷ 142)	20 <sup>+1</sup> (177 ÷ 186)

DCAT\_033\_028\_17661888

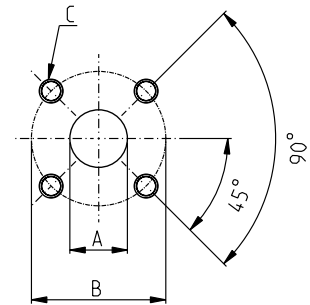

### EUROPEAN FLANGED PORTS - 4 Bolts

**EUROPEAN**

Metric thread ISO 60° conforms to ISO/R 262

CODE	A	B	C		
	mm (in)	mm (in)	Thread Depth mm (in)	Nm (lbf in)	Nm (lbf in)
<b>EA</b>	13 (0.5118)	30 (1.1811)	M 6 13 (0.5118)	8 <sup>+0,5</sup> (71 ÷ 75)	8 <sup>+0,5</sup> (71 ÷ 75)
<b>EB</b>	19 (0.7480)	40 (1.5748)	M 8 14 (0.5512)	15 <sup>+1</sup> (133 ÷ 142)	15 <sup>+1</sup> (133 ÷ 142)
			M 8 (◆) 18 (0.7087)	15 <sup>+1</sup> (◆) (133 ÷ 142)	15 <sup>+1</sup> (◆) (133 ÷ 142)
			M 10 18 (0.7087)	20 <sup>+1</sup> (177 ÷ 186)	35 <sup>+2,5</sup> (310 ÷ 332)
<b>ED</b>	27 (1.0630)	51 (2.0079)	M 10 18 (0.7087)	20 <sup>+1</sup> (177 ÷ 186)	35 <sup>+2,5</sup> (310 ÷ 332)
<b>EF</b>	33 (1.2992)	62 (2.4409)	M 12 18 (0.7087)	25 <sup>+1</sup> (221 ÷ 230)	50 <sup>+2,5</sup> (443 ÷ 465)

(◆) For POLARIS 30

DCAT\_006\_024\_21060533

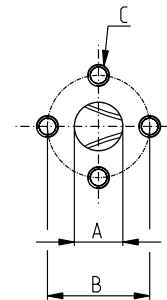

01/10.2003

## PORTS SIZES



Tightening torque for low pressure side port





Tightening torque for high pressure side port [values obtained at 5075 psi (350 bar)]

For reversible rotation, please consult only the tightening torque for high pressure side port

### SAE FLANGED PORTS J518 - Standard pressure series 3000 PSI

**SSM**

Metric thread ISO 60° to ISO/R 262



CODE	A	B	C	D		
	mm (in)	mm (in)	mm (in)	Thread Depth mm (in)	Nm (lbf in)	Nm (lbf in)
<b>MA</b>	12,5 (0.4921)	38,1 (1.50)	17,5 (0.6890)	M 8	15 <sup>+1</sup>	15 <sup>+1</sup>
				14 (0.5512)	(133 ÷ 142)	(133 ÷ 142)
				M 8 (◆)	20 <sup>+1</sup> (◆)	20 <sup>+1</sup> (◆)
<b>MB</b>	19 (0.7480)	47,6 (1.8740)	22,2 (0.8740)	M 10	20 <sup>+1</sup>	25 <sup>+1</sup>
				14 (0.5512)	(177 ÷ 186)	(266 ÷ 288)
				M 10 (◆)	20 <sup>+1</sup> (◆)	35 <sup>+2,5</sup> (◆)
<b>MC</b>	25,4 (1.0000)	52,4 (2.0630)	26,2 (1.0315)	M 10	20 <sup>+1</sup>	25 <sup>+1</sup>
				14 (0.5512)	(177 ÷ 186)	(266 ÷ 288)
				M 10 (◆)	20 <sup>+1</sup> (◆)	35 <sup>+2,5</sup> (◆)
<b>MD</b>	30,5 (1.2008)	58,7 (2.3110)	30,2 (1.1890)	M 10	20 <sup>+1</sup>	30 <sup>+2,5</sup>
				15 (0.5906)	(177 ÷ 186)	(266 ÷ 288)
				M 10 (◆)	20 <sup>+1</sup> (◆)	35 <sup>+2,5</sup> (◆)
<b>ME</b>	39,3 (1.5472)	69,8 (2.7480)	35,7 (1.4055)	M 12	30 <sup>+2,5</sup>	60 <sup>+5</sup>
				22 (0.8661)	(266 ÷ 288)	(531 ÷ 575)
<b>MF</b>	51 (2.0079)	77,8 (3.0630)	42,9 (1.6890)	M 12	30 <sup>+2,5</sup>	60 <sup>+5</sup>
				22 (0.8661)	(266 ÷ 288)	(531 ÷ 575)

(◆) For POLARIS 30

### SAE FLANGED PORTS J518 - Standard pressure series 3000 PSI

**SSS**

American straight thread UNC-UNF 60° conforms to ANSI B 1.1

CODE	A	B	C	D		
	mm (in)	mm (in)	mm (in)	Thread Depth mm (in)	Nm (lbf in)	Nm (lbf in)
<b>SA</b>	12,5 (0.4921)	38,1 (1.50)	17,5 (0.6890)	5/16-18 UNC-2B	15 <sup>+1</sup>	15 <sup>+1</sup>
				14 (0.5512)	(133 ÷ 142)	(133 ÷ 142)
				5/16-18 UNC-2B (◆)	20 <sup>+1</sup> (◆)	20 <sup>+1</sup> (◆)
<b>SB</b>	19 (0.7480)	47,6 (1.8740)	22,2 (0.8740)	3/8-16 UNC-2B	20 <sup>+1</sup>	20 <sup>+1</sup>
				14 (0.5512)	(177 ÷ 186)	(177 ÷ 186)
				3/8-16 UNC-2B (◆)	30 <sup>+2,5</sup> (◆)	20 <sup>+1</sup> (◆)
<b>SC</b>	25,4 (1.0000)	52,4 (2.0630)	26,2 (1.0315)	3/8-16 UNC-2B	20 <sup>+1</sup>	25 <sup>+1</sup>
				14 (0.5512)	(177 ÷ 186)	(221 ÷ 230)
				3/8-16 UNC-2B (◆)	20 <sup>+1</sup> (◆)	30 <sup>+2,5</sup> (◆)
<b>SD</b>	30,5 (1.2008)	58,7 (2.3110)	30,2 (1.1890)	7/16-14 UNC-2B	20 <sup>+1</sup>	45 <sup>+2,5</sup>
				22 (0.8661)	(177 ÷ 186)	(398 ÷ 420)
<b>SE</b>	39,3 (1.5472)	69,8 (2.7480)	35,7 (1.4055)	1/2-13 UNC-2B	30 <sup>+2,5</sup>	70 <sup>+5</sup>
				22 (0.8661)	(266 ÷ 288)	(620 ÷ 664)
<b>SF</b>	51 (2.0079)	77,8 (3.0630)	42,9 (1.6890)	1/2-13 UNC-2B	30 <sup>+2,5</sup> (◆)	70 <sup>+5</sup>
				22 (0.8661)	(266 ÷ 288)	(620 ÷ 664)

(◆) For POLARIS 30

DCAT\_006\_025\_21064252

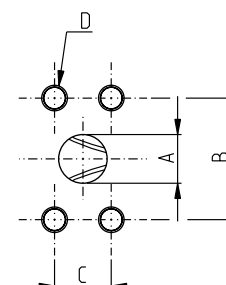

01/10.2003

DCAT\_006\_028\_21060740

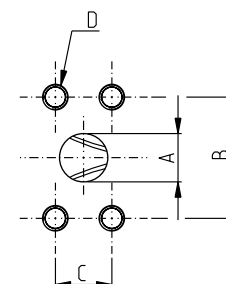

## PORTS SIZE



Tightening torque for low pressure side port



Tightening torque for high pressure side port [values obtained at 5075 psi (350 bar)]

For reversible rotation, please consult only the tightening torque for high pressure side port

### GAS STRAIGHT THREAD PORTS

**BSPP**

British standard pipe parallel (55°) conforms to UNI - ISO 228

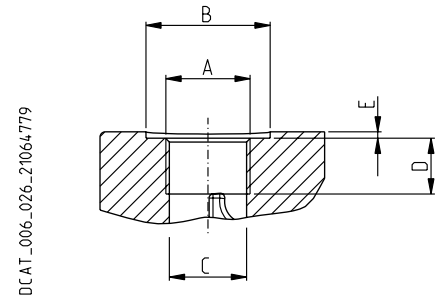

CODE	Nominal size	A	Ø B	Ø C	D	E	Nm (lbf in)	Nm (lbf in)
			mm (in)	mm (in)	mm (in)	mm (in)		
<b>GC</b>	3/8"	G 3/8	30 (#) (1.1811)	15 (0.5906)	10 (#) (0.3937)	2 (#) (0.0787)	15 <sup>+1</sup> (#) (133 ÷ 142)	—
			—		14 (0.5512)	—	15 <sup>+1</sup> (133 ÷ 142)	25 <sup>+1</sup> (221 ÷ 230)
<b>GD</b>	1/2"	G 1/2	—	19 (0.7480)	14 (0.5512)	—	20 <sup>+1</sup> (177 ÷ 186)	50 <sup>+2,5</sup> (443 ÷ 465)
			—		17 (◆) (0.6693)	—	—	—
<b>GE</b>	3/4"	G 3/4	—	24,5 (0.9646)	18 (0.7087)	—	30 <sup>+2,5</sup> (266 ÷ 288)	90 <sup>+5</sup> (797 ÷ 841)
<b>GF</b>	1"	G 1	—	30,5 (1.2008)	18 (0.7086)	—	50 <sup>+2,5</sup> (443 ÷ 465)	130 <sup>+10</sup> (1151 ÷ 1239)
<b>GG</b>	1" 1/4	G 1 1/4	—	39 (1.5354)	22 (0.8661)	—	60 <sup>+5</sup> (531 ÷ 575)	170 <sup>+10</sup> (1505 ÷ 1593)
<b>GH</b>	1" 1/2	G 1 1/2	—	45 (1.7716)	24 (0.9448)	—	70 <sup>+5</sup> (620 ÷ 664)	210 <sup>+15</sup> (1859 ÷ 1992)

# = Drain port

(◆) For POLARIS 20

02/07.2006

## PORTS SIZES



Tightening torque for low pressure side port



Tightening torque for high pressure side port [values obtained at 5075 psi (350 bar)]

For reversible rotation, please consult only the tightening torque for high pressure side port

### SAE STRAIGHT THREAD PORTS J514

**ODT**

American straight thread UNC-UNF 60° conforms to ANSI B 1.1

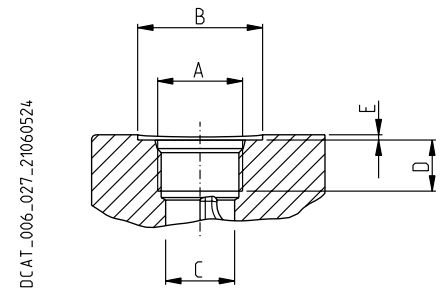

CODE	Nominal size	A	Ø B		Ø C		D		E	
			mm (in)	mm (in)	mm (in)	mm (in)	mm (in)	Nm (lbf in)	Nm (lbf in)	
<b>OA</b>	3/8"	9/16" - 18 UNF - 2B	26 (1.0236)	13 (0.5118)	15 (0.5906)	1	15 <sup>+1</sup>	25 <sup>+1</sup>		
						(0.03934)	(133 ÷ 142)	(221 ÷ 230)	2 (#)	15 <sup>+1</sup> (#)
<b>OB</b>	1/2"	3/4" - 16 UNF - 2B	32 (1.2598)	17,5 (0.690)	15 (0.5906)	—	20 <sup>+1</sup>	45 <sup>+2,5</sup>		
							(177 ÷ 186)	(398 ÷ 420)		
<b>OC</b>	5/8"	7/8" - 14 UNF - 2B	35 (1.3780)	20,5 (0.8071)	15 (◆)	0,5	30 <sup>+2,5</sup>	70 <sup>+5</sup>		
					(0.5906)	(0.0197)	(266 ÷ 288)	(620 ÷ 664)	17	
					(0.6693)					
<b>OD</b>	3/4"	1 1/16" - 12 UNF - 2B	42 (1.6535)	24,8 (0.9764)	20 (0.7874)	0,5 (0.0197)	40 <sup>+2,5</sup> (354 ÷ 376)	120 <sup>+10</sup> (1062 ÷ 1151)		
<b>OF</b>	1"	1 5/16" - 12 UNF - 2B	49 (1.9291)	30,5 (1.2008)	20 (0.7874)	0,5 (0.0197)	60 <sup>+5</sup> (531 ÷ 575)	170 <sup>+10</sup> (1505 ÷ 1593)		
<b>OG</b>	1" 1/4	1 5/8" - 12 UNF - 2B	58 (2.2835)	39,1 (1.5394)	20 (0.7874)	0,5 (0.0197)	70 <sup>+5</sup> (620 ÷ 664)	200 <sup>+15</sup> (1770 ÷ 1858)		
<b>OH</b>	1" 1/2	1 7/8" - 12 UNF - 2B	65 (2.5591)	45 (1.7717)	20 (0.7874)	0,5 (0.0197)	100 <sup>+5</sup> (885 ÷ 929)	270 <sup>+15</sup> (2389 ÷ 2522)		

(#) = Drain port

(◆) For POLARIS 10

01/10.2003



## VALVE OPTIONS

### PRIORITY VALVE

**P1**

Costant delivery and internal recirculation of excess flow.

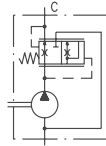

**P2**

Costant delivery at controlled pressure. Internal recirculation of excess flow and drain valve.

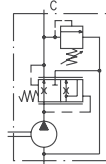

**P3**

Costant delivery at controlled pressure. Excess flow and drain valve must be connected to tank.

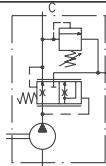

**P4**

Costant delivery and excess flow can both be used under load.

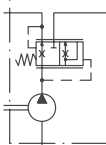

**P5T**

Costant delivery at controlled pressure with drain valve connected to tank. Excess flow can be used under load.

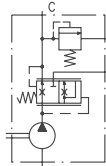

### ELECTRIC VALVE FOR MOTORS

**UNL**

By-pass valve normally closed with max. pressure relief valve and anti-cavitation valve.

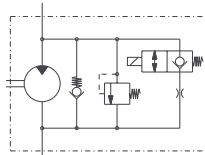

**PRV**

Proportional relief valve and anti-cavitation valve.

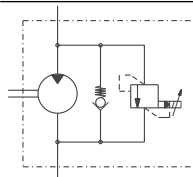

◆ For more information please consult our built-in valves technical catalogue and our pre-sales department

### MAX PRESSURE RELIEF VALVE

**VPEF..**

Fixed setting with external drain.

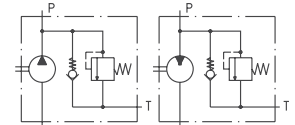

**VPIF..**

Fixed setting with internal drain.

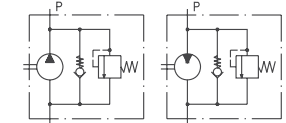

**VPER..**

Adjustable setting with external drain.

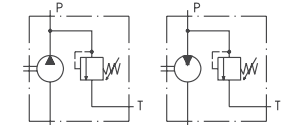

**VPIR..**

Adjustable setting with internal drain.

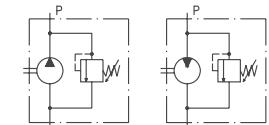

### LOAD SENSING VALVE

...

Static.

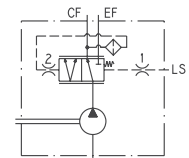

...

Dynamic.

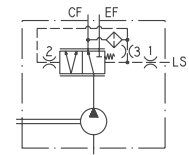

...

Dynamic with relief valve fitted on the main line.

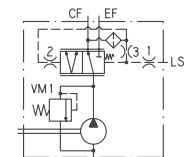

...

Dynamic with relief valve fitted on controlled line.

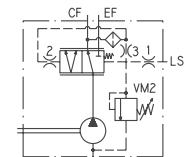

### CHECK VALVE

**V8**

Anti-cavitation valve.

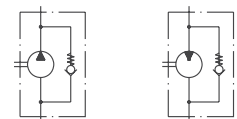

Replaces: 01/10.2003

04/10.2020

---

## NOTES

---

0 04/10.2020

## HOW TO ORDER POLARIS 10 SINGLE UNITS

1	2	3	4	5	6	7	8	9	10	11	12	13							
<b>PLP 10-1</b>	<b>L</b>	<b>0</b>	<b>-</b>	<b>81</b>	<b>E1</b>	<b>-</b>	<b>L</b>	<b>BB/BA</b>	<b>-</b>	<b>N</b>	<b>-</b>	<b>EL</b>	<b>-</b>	<b>C</b>	<b>-</b>	<b>L</b>	<b>GA</b>	<b>-</b>	<b>FS</b>

1	Type	Pump type	Motor type
	1,07 cm <sup>3</sup> /rev (0.07 in <sup>3</sup> /rev)	<b>PLP 10-1</b>	<b>PLM 10-1</b>
	1,60 cm <sup>3</sup> /rev (0.10 in <sup>3</sup> /rev)	<b>PLP 10-1,5</b>	<b>PLM 10-1,5</b>
	2,13 cm <sup>3</sup> /rev (0.13 in <sup>3</sup> /rev)	<b>PLP 10-2</b>	<b>PLM 10-2</b>
	2,67 cm <sup>3</sup> /rev (0.16 in <sup>3</sup> /rev)	<b>PLP 10-2,5</b>	<b>PLM 10-2,5</b>
	3,34 cm <sup>3</sup> /rev (0.20 in <sup>3</sup> /rev)	<b>PLP 10-3,15</b>	<b>PLM 10-3,15</b>
	4,27 cm <sup>3</sup> /rev (0.26 in <sup>3</sup> /rev)	<b>PLP 10-4</b>	<b>PLM 10-4</b>
	5,34 cm <sup>3</sup> /rev (0.33 in <sup>3</sup> /rev)	<b>PLP 10-5</b>	<b>PLM 10-5</b>
	6,20 cm <sup>3</sup> /rev (0.38 in <sup>3</sup> /rev)	<b>PLP 10-5,8</b>	<b>PLM 10-5,8</b>
	6,67 cm <sup>3</sup> /rev (0.41 in <sup>3</sup> /rev)	<b>PLP 10-6,3</b>	<b>PLM 10-6,3</b>
	8,51 cm <sup>3</sup> /rev (0.52 in <sup>3</sup> /rev)	<b>PLP 10-8</b>	<b>PLM 10-8</b>
	10,67 cm <sup>3</sup> /rev (0.65 in <sup>3</sup> /rev)	<b>PLP 10-10</b>	<b>PLP 10-10</b>

2	Rotation	Code
	Left	<b>S</b>
	Right	<b>D</b>
	Reversible rear external drain	<b>R</b>
	Reversible side external drain	<b>L</b>
	Reversible internal drain	<b>B</b>

3	Versions - Outboard bearing options	Code
	Without outboard bearing	<b>0</b>

4	Drive shaft	Code
	European tapered 1:8	<b>81</b>
	European tapered 1:8	<b>86</b>
	SAE "AA" spline (9 teeth)	<b>02</b>
	SAE "AA" straight	<b>30</b>
	SAE straight	<b>36</b>
	Straight	<b>29</b>

5	Mounting flange	Code
	European	<b>E1</b>
	European	<b>E7</b>
	European	<b>E8</b>
	German 2 bolt	<b>B1</b>
	German 4 bolt	<b>K2</b>
	SAE "AA" 2 bolt	<b>S0</b>
	SAE "AA" 2-4 bolt	<b>R9</b>
	SAE 2-4 bolt	<b>R8</b>
	SAE 2 bolt	<b>W9</b>

Code	Ports position	6
<b>L</b>	Side	
<b>P</b>	Rear	

Code	Ports IN/OUT	7
<b>GERMAN FLANGED PORTS</b>		
Side	Rear	Type
<b>BB/BA</b>	PLP 10	1-1,5-2-2,5-3,15
<b>BA/BB</b>	PLM 10	4-5-5,8-6,3-8-10

<b>GAS STRAIGHT THREAD PORTS (BSPP)</b>		
Side	Rear	Type
<b>GC/GC</b>	<b>GC/GC</b>	PLP 10 PLM 10
		1-1,5-2-2,5-3,15-4
<b>GD/GD</b>	<b>GD/GD</b>	PLP 10 PLM 10
		5-5,8-6,3-8-10

<b>SAE STRAIGHT THREAD PORTS (ODT)</b>		
Side	Rear	Type
<b>OB/OA</b>	<b>OB/OA</b>	PLP 10
<b>OA/OB</b>	<b>OA/OB</b>	PLM 10
		1-1,5-2-2,5-3,15-4 5-5,8-6,3
<b>OC/OB</b>	<b>OB/OB</b>	PLP 10
<b>OB/OC</b>	<b>OB/OB</b>	PLM 10
		8-10

Code	Seals (a)	8
<b>N</b>	Buna (standard)	
<b>V</b>	Viton	

Code	Cover options (b)	9
	Cast iron mounting flange and rear cover (standard - no code)	
<b>E</b>	Aluminium mounting flange and cast iron rear cover	
<b>L</b>	Cast iron mounting flange and aluminium rear cover	
<b>EL</b>	Aluminium mounting flange and rear cover	

Code	Shaft seal options	10
<b>D</b>	Standard seal with wiper seal	
<b>C1</b>	High back pressure seal	

Replaces: 02/07.2006

04/10.2020

## HOW TO ORDER POLARIS 10 SINGLE UNITS

11	Drain port position - Rev. Rotation L	Code
	Side drain with side port position	<b>L</b>
	Side drain with bottom port position	<b>*</b>

12	Drain port	Code
<b>IN/OUT GERMAN FLANGED PORTS</b>		
	Type	Side      Rear
	1-1,5-2-2,5-3,15 <u>PLP 10</u>	<b>GA</b>
	4-5-5,8-6,3-8-10 <u>PLM 10</u>	
<b>IN/OUT GAS STRAIGHT THREAD PORTS (BSPP)</b>		
	Type	Side      Rear
	1-1,5-2-2,5-3,15 <u>PLP 10</u>	<b>GA</b> <b>GA</b>
	4-5-5,8-6,3-8-10 <u>PLM 10</u>	
<b>IN/OUT SAE STRAIGHT THREAD PORTS (ODT)</b>		
	Type	Side      Rear
	1-1,5-2-2,5-3,15 <u>PLP 10</u>	<b>03</b> <b>03</b>
	4-5-5,8-6,3-8-10 <u>PLM 10</u>	

13	Shaft arrangement	Code
	Female spline	<b>FS</b>

- (a) Choose the seals according to the temperature shown on page 5
- (b) Mounting flange material on page 58 ÷ 60  
Rear cover material on page 34

02/07.2006

## HOW TO ORDER POLARIS 20 SINGLE UNITS

1	2	3	4	5	6	7	8	9	10	11	12	13							
<b>PLP 20-4</b>	<b>L</b>	<b>0</b>	<b>-</b>	<b>82</b>	<b>E2</b>	<b>-</b>	<b>L</b>	<b>EA/EA</b>	<b>-</b>	<b>N</b>	<b>-</b>	<b>EL</b>	<b>-</b>	<b>C</b>	<b>-</b>	<b>*</b>	<b>GB</b>	<b>-</b>	<b>FS</b>

1	Type	Pump type	Motor type
4,95 cm <sup>3</sup> /rev (0.30 in <sup>3</sup> /rev)		<b>PLP 20-4</b>	<b>PLM 20-4</b>
6,61 cm <sup>3</sup> /rev (0.40 in <sup>3</sup> /rev)		<b>PLP 20-6,3</b>	<b>PLM 20-6,3</b>
7,29 cm <sup>3</sup> /rev (0.44 in <sup>3</sup> /rev)		<b>PLP 20-7,2</b>	<b>PLM 20-7,2</b>
8,26 cm <sup>3</sup> /rev 0.50 in <sup>3</sup> /rev)		<b>PLP 20-8</b>	<b>PLM 20-8</b>
9,17 cm <sup>3</sup> /rev 0.56 in <sup>3</sup> /rev)		<b>PLP 20-9</b>	<b>PLM 20-9</b>
10,9 cm <sup>3</sup> /rev (0.66 in <sup>3</sup> /rev)		<b>PLP 20-10,5</b>	<b>PLM 20-10,5</b>
11,23 cm <sup>3</sup> /rev (0.69 in <sup>3</sup> /rev)		<b>PLP 20-11,2</b>	<b>PLM 20-11,2</b>
14,53 cm <sup>3</sup> /rev (0.89 in <sup>3</sup> /rev)		<b>PLP 20-14</b>	<b>PLM 20-14</b>
16,85 cm <sup>3</sup> /rev (1.03 in <sup>3</sup> /rev)		<b>PLP 20-16</b>	<b>PLM 20-16</b>
19,09 cm <sup>3</sup> /rev (1.16 in <sup>3</sup> /rev)		<b>PLP 20-19</b>	<b>PLM 20-19</b>
21,14 cm <sup>3</sup> /rev (1.29 in <sup>3</sup> /rev)		<b>PLP 20-20</b>	<b>PLM 20-20</b>
24,84 cm <sup>3</sup> /rev 1.52 in <sup>3</sup> /rev)		<b>PLP 20-24,5</b>	<b>PLM 20-24,5</b>
26,42 cm <sup>3</sup> /rev (1.61 in <sup>3</sup> /rev)		<b>PLP 20-25</b>	<b>PLM 20-25</b>
28,21 cm <sup>3</sup> /rev (1.72 in <sup>3</sup> /rev)		<b>PLP 20-27,8</b>	<b>PLM 20-27,8</b>
33,03 cm <sup>3</sup> /rev (2.01 in <sup>3</sup> /rev)		<b>PLP 20-31,5</b>	<b>PLM 20-31,5</b>

2	Rotation	Code
Left		<b>S</b>
Right		<b>D</b>
Reversible rear external drain		<b>R</b>
Reversible side external drain		<b>L</b>
Reversible internal drain		<b>B</b>

3	Versions - Outboard bearing options	Code
Without outboard bearing		<b>0</b>
With outboard bearing		<b>W8</b>
With outboard bearing		<b>5</b>
With outboard bearing		<b>6</b>
With outboard bearing		<b>7</b>
With outboard bearing		<b>9</b>

4	Drive shaft	Code
European tapered 1:8		<b>82</b>
German tapered 1:5		<b>54</b>
German tapered 1:5		<b>55</b>
Straight		<b>46</b>
SAE "A" spline (9 teeth)		<b>03</b>
SAE spline (10 teeth)		<b>01</b>
SAE "A" spline (11 teeth)		<b>07</b>
SAE "A" straight		<b>31</b>

Code	Drive shaft	4
<b>49</b>	Straight	
<b>50</b>	Straight	
<b>04</b>	SAE "B" spline	
<b>32</b>	SAE "B" straight	
<b>12</b>	DIN 54 82	
<b>48</b>	Straight (only for version 6)	
<b>B1</b>	Straight (for version 5 and 8)	
<b>95</b>	Tang	

Code	Mounting flange	5
<b>E2</b>	European	
<b>B2</b>	German	
<b>B4</b>	German 2 bolt	
<b>B5</b>	German 2 bolt	
<b>B6</b>	German 4 bolt	
<b>U2</b>	German 2 bolt	
<b>S1</b>	SAE "A" 2 bolt	
<b>S2</b>	SAE "A" 2 bolt	
<b>S9</b>	SAE "A" 2 bolt	
<b>S5</b>	SAE "B" 2 bolt	
<b>W8</b>	German	

Code	Ports position	6
<b>L</b>	Side	
<b>P</b>	Rear	

Code	Ports IN/OUT	7
<b>GERMAN FLANGED PORTS</b>		
Side	Rear	Type
<b>BE/BC</b>	PLP 20	4-6,3-7,2-8-9-10,5-11,2
<b>BC/BE</b>	PLM 20	14-16-19-20-24,5-25-27,8-31,5
<b>EUROPEAN FLANGED PORTS</b>		
Side	Rear	Type
<b>EA/EA</b>	PLP 20	4-6,3-7,2-8-9-10,5-11,2
<b>EB/EA</b>	PLM 20	14-16-19-20-24,5-25-27,8-31,5
<b>EA/EB</b>	PLM 20	27,8-31,5

Replaces: 01/10.2003

04/10.2020

## HOW TO ORDER POLARIS 20 SINGLE UNITS

Replaces: 02/07.2006

7	Ports IN/OUT	Code
<b>SAE FLANGED PORTS (SSM)</b>		
Type	Side	Rear
4-6,3-7,2-8-9-10,5-11,2	PLP 20	<b>MA/MA</b>
	PLM 20	
14-16-19-20	PLP 20	<b>MB/MA</b>
	PLM 20	<b>MA/MB</b>
24,5-25-27,8-31,5	PLP 20	<b>MC/MB</b>
	PLM 20	<b>MB/MC</b>
<b>SAE FLANGED PORTS (SSS)</b>		
Type	Side	Rear
4-6,3-7,2-8-9-10,5-11,2	PLP 20	<b>SA/SA</b>
	PLM 20	
14-16-19-20	PLP 20	<b>SB/SA</b>
	PLM 20	<b>SA/SB</b>
24,5-25-27,8-31,5	PLP 20	<b>SC/SB</b>
	PLM 20	<b>SB/SC</b>
<b>GAS STRAIGHT THREAD PORTS (BSPP)</b>		
Type	Side	Rear
4-6,3-7,2-8-9 10,5-11,2	PLP 20	<b>GD/GD</b>
	PLM 20	<b>GD/GD</b>
14-16-19-20-24,5-25 27,8-31,5	PLP 20	<b>GE/GD</b>
	PLM 20	<b>GD/GE</b>
<b>SAE STRAIGHT THREAD PORTS (ODT)</b>		
Type	Side	Rear
4-6,3-7,2-8-9-10,5-11,2	PLP 20	<b>OC/OC</b>
	PLM 20	<b>OC/OC</b>
14-16-19-20-24,5-25 27,8-31,5	PLP 20	<b>OD/OC</b>
	PLM 20	<b>OC/OD</b>

8	Seals (a)	Code
	Buna (standard)	<b>N</b>
	Viton	<b>V</b>
	Hydrogenated buna HNBR seals with Viton-FKM shaft seals	<b>T-PV</b>

04/10.2020

9	Cover options (b)	Code
	Cast iron mounting flange and rear cover (standard - no code)	
	Aluminium mounting flange and cast iron rear cover	<b>E</b>
	Cast iron mounting flange and aluminium rear cover	<b>L</b>
	Aluminium mounting flange and rear cover	<b>EL</b>

10	Shaft seal options	Code
	Standard seal with wiper seal	<b>D</b>
	High back pressure seal	<b>C1</b>

Code	Drain port position - Rev. rotation L	11
<b>L</b>	Side drain with side port position	
<b>*</b>	Side drain with bottom port position	

Code	Drain port	12
<b>IN/OUT GERMAN FLANGED PORTS</b>		
Side	Rear	Type
<b>TA</b>	PLP 20	4-6,3-7,2-8-9-10,5-11,2
	PLM 20	24,5-25-27,8-31,5

<b>IN/OUT EUROPEAN FLANGED PORTS</b>		
Side	Rear	Type
<b>GB</b>	PLP 20	4-6,3-7,2-8-9-10,5-11,2
	PLM 20	24,5-25-27,8-31,5

<b>IN/OUT SAE FLANGED PORTS (SSM)</b>		
Side	Rear	Type
<b>GB</b>	PLP 20	4-6,3-7,2-8-9-10,5-11,2
	PLM20	24,5-25-27,8-31,5

<b>IN/OUT SAE FLANGED PORTS (SSS)</b>		
Side	Rear	Type
<b>03</b>	PLP 20	4-6,3-7,2-8-9-10,5-11,2
	PLM 20	24,5-25-27,8-31,5

<b>IN/OUT GAS STRAIGHT THREAD PORTS (BSPP)</b>		
Side	Rear	Type
<b>GB</b>	<b>GB</b> PLP 20	4-6,3-7,2-8-9-10,5-11,2
	PLM 20	24,5-25-27,8-31,5

<b>IN/OUT SAE STRAIGHT THREAD PORTS (ODT)</b>		
Side	Rear	Type
<b>03</b>	<b>03</b> PLP 20	4-6,3-7,2-8-9-10,5-11,2
	PLM 20	24,5-25-27,8-31,5

Code	Shaft arrangement	13
<b>FS</b>	Female spline	

- (a) Choose the seals according to the temperature shown on page 4.
- (b) Mounting flange material on page 61 ÷ 66  
Rear cover material on page 34 ÷ 35

## HOW TO ORDER POLARIS 30 SINGLE UNITS

1	2	3	4	5	6	7	8	9	10
<b>PLP 30-22</b>	<b>R</b>	<b>0</b>	<b>- 83</b>	<b>E3</b>	<b>- L</b>	<b>ED/EB</b>	<b>- N</b>	<b>- C</b>	<b>- FS</b>

1	Type	Pump type	Motor type
	21,99 cm <sup>3</sup> /rev (1.34 in <sup>3</sup> /rev)	<b>PLP 30-22</b>	<b>PLM 30-22</b>
	26,70 cm <sup>3</sup> /rev (1.63 in <sup>3</sup> /rev)	<b>PLP 30-27</b>	<b>PLM 30-27</b>
	34,55 cm <sup>3</sup> /rev (2.11 in <sup>3</sup> /rev)	<b>PLP 30-34</b>	<b>PLM 30-34</b>
	39,27 cm <sup>3</sup> /rev (2.40 in <sup>3</sup> /rev)	<b>PLP 30-38</b>	<b>PLM 30-38</b>
	43,98 cm <sup>3</sup> /rev (2.68 in <sup>3</sup> /rev)	<b>PLP 30-43</b>	<b>PLM 30-43</b>
	51,83 cm <sup>3</sup> /rev (3.16 in <sup>3</sup> /rev)	<b>PLP 30-51</b>	<b>PLM 30-51</b>
	61,26 cm <sup>3</sup> /rev (3.74 in <sup>3</sup> /rev)	<b>PLP 30-61</b>	<b>PLM 30-61</b>
	73,82 cm <sup>3</sup> /rev (4.50 in <sup>3</sup> /rev)	<b>PLP 30-73</b>	<b>PLM 30-73</b>
	81,68 cm <sup>3</sup> /rev (4.98 in <sup>3</sup> /rev)	<b>PLP 30-82</b>	<b>PLM 30-82</b>
	91,10 cm <sup>3</sup> /rev (5.56 in <sup>3</sup> /rev)	<b>PLP 30-90</b>	<b>PLM 30-90</b>

2	Rotation	Code
	Left	<b>S</b>
	Right	<b>D</b>
	Reversible rear external drain	<b>R</b>

3	Versions - Outboard bearing options	Code
	Without outboard bearing	<b>0</b>

4	Drive shaft	Code
	European tapered 1:8	<b>83</b>
	European tapered 1:8	<b>84</b>
	German tapered 1:5	<b>56</b>
	Straight	<b>41</b>
	SAE "B" spline	<b>A8</b>
	SAE "BB" spline	<b>A5</b>
	SAE "B" spline	<b>04</b>
	SAE "BB" spline	<b>05</b>
	SAE "B" straight	<b>32</b>
	SAE "BB" straight	<b>33</b>

5	Mounting flange	Code
	European	<b>E3</b>
	European	<b>E4</b>
	German	<b>B3</b>
	SAE "B" 2 bolt	<b>S5</b>
	SAE "B" 2 bolt	<b>U3</b>

6	Ports position	Code
	Side	<b>L</b>

Code	Ports IN/OUT	7
<b>GERMAN FLANGED PORTS</b>		
Side	Type	
<b>BM/BL</b>	PLP 30	22-27-34-38-43
<b>BL/BM</b>	PLM 30	46-51-61-73-82-90
<b>EUROPEAN FLANGED PORTS</b>		
Side	Type	
<b>ED/EB</b>	PLP 30	22-27-34-38-43
<b>EB/ED</b>	PLM 30	46-51-61
<b>EF/ED</b>	PLP 30	73-82-90
<b>ED/EF</b>	PLM 30	
<b>SAE FLANGED PORTS (SSM)</b>		
Side	Type	
<b>MB/MA</b>	PLP 30	22
<b>MA/MB</b>	PLM 30	
<b>MC/MB</b>	PLP 30	27-34
<b>MB/MC</b>	PLM 30	
<b>MD/MC</b>	PLP 30	38-43-46-51
<b>MC/MD</b>	PLM 30	
<b>ME/MD</b>	PLP 30	61-73-82
<b>MD/ME</b>	PLM 30	
<b>MF/ME</b>	PLP 30	90
<b>ME/MF</b>	PLM 30	
<b>SAE FLANGED PORTS (SSS)</b>		
Side	Type	
<b>SB/SA</b>	PLP 30	22
<b>SA/SB</b>	PLM 30	
<b>SC/SB</b>	PLP 30	27-34
<b>SB/SC</b>	PLM 30	
<b>SD/SC</b>	PLP 30	38-43-46-51
<b>SC/SB</b>	PLM 30	
<b>SE/SD</b>	PLP 30	61-73-82
<b>SD/SE</b>	PLM 30	
<b>SF/SE</b>	PLP 30	90
<b>SE/SF</b>	PLM 30	
<b>GAS STRAIGHT THREAD PORTS (BSPP)</b>		
Side	Type	
<b>GF/GF</b>	PLP 30	22-27-34-38-43-46-51
<b>GG/GF</b>	PLM 30	
<b>GF/GG</b>	PLP 30	61-73
<b>GH/GG</b>	PLM 30	
<b>GG/GH</b>	PLP 30	82-90
<b>GG/GH</b>	PLM 30	

02/07.2006

## HOW TO ORDER POLARIS 30 SINGLE UNITS

Replaces: 01/10.2003

<b>7</b>	<b>Ports IN/OUT</b>	Code
----------	---------------------	------

SAE STRAIGHT THREAD PORTS (ODT)		
Type		Rear
22-27-34	PLP 30	OF/OD
	PLM 30	OD/OF
38-43-46-51	PLP 30	OG/OF
	PLM 30	OF/OG
61-73-82-90	PLP 30	OH/OG
	PLM 30	OG/OH

<b>8</b>	<b>Seals (a)</b>	Code
----------	------------------	------

Buna (standard)	N
Viton	V

<b>9</b>	<b>○ Shaft seal options</b>	Code
----------	-----------------------------	------

Standard seal with wiper seal	D
High back pressure seal	C1

<b>10</b>	<b>Shaft arrangement</b>	Code
-----------	--------------------------	------

Female spline	FS
---------------	----

- (a) Choose the seals according to the temperature shown on page 5.

○ 04/10.2020



## HOW TO ORDER POLARIS 10 MULTIPLE PUMPS

1	2	3	4	5	6	7	8	9	10	11	12								
<b>PLP 10-1</b>	-	<b>81</b>	<b>E1</b>	-	<b>L</b>	<b>BA/BA</b>	/												
<b>Front section</b>																			
<b>10-1</b>	-				<b>L</b>	<b>BA/BA</b>	/												
<b>Intermediate section</b>																			
<b>10-1</b>	-				<b>L</b>	<b>**/BA</b>	-	<b>V7</b>	-	<b>S</b>	<b>0</b>	-	<b>N</b>	-	<b>EL</b>	-	<b>C</b>	/	<b>FS</b>
<b>Rear section</b>																			

1	Type	Pump type
0.07 in <sup>3</sup> /rev (1,07 cm <sup>3</sup> /rev)		<b>PLP 10-1</b>
1,60 cm <sup>3</sup> /rev (0.10 in <sup>3</sup> /rev)		<b>PLP 10-1,5</b>
2,13 cm <sup>3</sup> /rev (0.13 in <sup>3</sup> /rev)		<b>PLP 10-2</b>
2,67 cm <sup>3</sup> /rev 0.16 in <sup>3</sup> /rev)		<b>PLP 10-2,5</b>
3,34 cm <sup>3</sup> /rev (0.20 in <sup>3</sup> /rev)		<b>PLP 10-3,15</b>
4,27 cm <sup>3</sup> /rev 0.26 in <sup>3</sup> /rev)		<b>PLP 10-4</b>
5,34 cm <sup>3</sup> /rev (0.33 in <sup>3</sup> /rev)		<b>PLP 10-5</b>
6,20 cm <sup>3</sup> /rev (0.38 in <sup>3</sup> /rev)		<b>PLP 10-5,8</b>
6,67 cm <sup>3</sup> /rev (0.41 in <sup>3</sup> /rev)		<b>PLP 10-6,3</b>
8,51 cm <sup>3</sup> /rev (0.52 in <sup>3</sup> /rev)		<b>PLP 10-8</b>
10,67 cm <sup>3</sup> /rev (0.65 in <sup>3</sup> /rev)		<b>PLP 10-10</b>

2	Drive shaft	Code
European tapered 1:8		<b>81</b>
European tapered 1:8		<b>86</b>
SAE "AA" spline (9 teeth)		<b>02</b>
SAE "AA" straight		<b>30</b>
SAE straight		<b>36</b>
Straight		<b>29</b>

3	Mounting flange	Code
European		<b>E1</b>
European		<b>E7</b>
European		<b>E8</b>
German 2 bolts		<b>B1</b>
German 4 bolts		<b>K2</b>
SAE "AA" 2 bolt		<b>S0</b>
SAE "AA" 2-4 bolt		<b>R9</b>
SAE 2-4 bolt		<b>R8</b>
SAE 2 bolt		<b>W9</b>

4	Ports position	Code
Side		<b>L</b>

Code	Ports IN/OUT	5
<b>GERMAN FLANGED PORTS</b>		
Side	Type	
<b>BB/BA</b>	PLP 10	1-1,5-2-2,5-3,15-4-5-5,8-6,3-8-10
<b>GAS STRAIGHT THREAD PORTS (BSPP)</b>		
Side	Type	
<b>GC/GC</b>	PLP 10	1-1,5-2-2,5-3,15-4
<b>GD/GD</b>	PLP 10	5-5,8-6,3-8-10
<b>SAE STRAIGHT THREAD PORTS (ODT)</b>		
Side	Type	
<b>OB/OA</b>	PLP 10	1-1,5-2-2,5-3,15-4-5-5,8-6,3
<b>OC/OB</b>	PLP 10	8-10

Code	Combination type	6
<b>V6</b>	Standard	
<b>V7</b>	Common inlet	

Code	Rotation	7
<b>S</b>	Left	
<b>D</b>	Right	

Code	Versions - Outboard bearing options	8
<b>0</b>	Without outboard bearing (standard) no code	

Code	Seals (a)	9
<b>N</b>	Buna N (standard)	
<b>V</b>	Viton	

Code	Cover options (b)	10
	Cast iron mounting flange and rear cover (standard - no code)	
<b>E</b>	Aluminium mounting flange and cast iron rear cover	
<b>L</b>	Cast iron mounting flange and aluminium rear cover	
<b>EL</b>	Aluminium mounting flange and rear cover	

02/07.2006

## HOW TO ORDER POLARIS 10 MULTIPLE PUMPS

11	 Shaft seal options	Code
	Standard seal with wiper seal	<b>D</b>
	High back pressure seal	<b>C1</b>

12	Shaft arrangement	Code
	Female spline	<b>FS</b>

Replaces: 02/07.2006

- (a) Choose the seals according to the temperature shown on page 5.
- (b) Mounting flange material on page 58 ÷ 60  
Rear cover material on page 44

 04/10.2020

## HOW TO ORDER POLARIS 20 MULTIPLE PUMPS

1	2	3	4	5	6	7	8	9	10	11	12							
<b>PLP 20-4</b>	-	<b>82</b>	<b>E2</b>	-	<b>L</b>	<b>EA/EA</b>	/											
<b>Front section</b>																		
<b>20-4</b>	-			<b>L</b>	<b>EA/EA</b>	/												
<b>Intermediate section</b>																		
<b>20-4</b>	-			<b>L</b>	<b>**/EA</b>	-	<b>S7</b>	-	<b>S</b>	<b>0</b>	-	<b>N</b>	-	<b>EL</b>	-	<b>C</b>	/	<b>FS</b>
<b>Rear section</b>																		

1	Type	Pump Type
4,95 cm <sup>3</sup> /rev (0.30 in <sup>3</sup> /rev)		<b>PLP 20-4</b>
6,61 cm <sup>3</sup> /rev (0.40 in <sup>3</sup> /rev)		<b>PLP 20-6,3</b>
7,29 cm <sup>3</sup> /rev (0.44 in <sup>3</sup> /rev)		<b>PLP 20-7,2</b>
8,26 cm <sup>3</sup> /rev (0.50 in <sup>3</sup> /rev)		<b>PLP 20-8</b>
9,17 cm <sup>3</sup> /rev (0.56 in <sup>3</sup> /rev)		<b>PLP 20-9</b>
10,9 cm <sup>3</sup> /rev (0.66 in <sup>3</sup> /rev)		<b>PLP 20-10,5</b>
11,23 cm <sup>3</sup> /rev (0.69 in <sup>3</sup> /rev)		<b>PLP 20-11,2</b>
14,53 cm <sup>3</sup> /rev (0.89 in <sup>3</sup> /rev)		<b>PLP 20-14</b>
16,85 cm <sup>3</sup> /rev (1.03 in <sup>3</sup> /rev)		<b>PLP 20-16</b>
19,09 cm <sup>3</sup> /rev (1.16 in <sup>3</sup> /rev)		<b>PLP 20-19</b>
21,14 cm <sup>3</sup> /rev (1.29 in <sup>3</sup> /rev)		<b>PLP 20-20</b>
24,84 cm <sup>3</sup> /rev (1.52 in <sup>3</sup> /rev)		<b>PLP 20-24,5</b>
26,42 cm <sup>3</sup> /rev (1.61 in <sup>3</sup> /rev)		<b>PLP 20-25</b>
28,21 cm <sup>3</sup> /rev (1.72 in <sup>3</sup> /rev)		<b>PLP 20-27,8</b>
33,03 cm <sup>3</sup> /rev (2.01 in <sup>3</sup> /rev)		<b>PLP 20-31,5</b>

2	Drive shaft	Code
European tapered 1:8		<b>82</b>
German tapered 1:5		<b>54</b>
German tapered 1:5		<b>55</b>
Straight		<b>46</b>
SAE "A" spline (9 teeth)		<b>03</b>
SAE spline (10 teeth)		<b>01</b>
SAE "A" spline (11 teeth)		<b>07</b>
SAE "A" straight		<b>31</b>
Straight		<b>49</b>
Straight		<b>50</b>
SAE "B" spline		<b>04</b>
SAE "B" straight		<b>32</b>
DIN 54 82 spline		<b>12</b>
Straight (only for version 6)		<b>48</b>
Straight (only for version 8)		<b>B1</b>
Tang		<b>95</b>

Code	Mounting flange	3
<b>E2</b>	European	
<b>B2</b>	German	
<b>B4</b>	German 2 bolt	
<b>B5</b>	German 2 bolt	
<b>B6</b>	German 4 bolt	
<b>U2</b>	German 2 bolt	
<b>S1</b>	SAE "A" 2 bolt	
<b>S2</b>	SAE "A" 2 bolt	
<b>S9</b>	SAE "A" 2 bolt	
<b>S5</b>	SAE "B" 2 bolt	
<b>W8</b>	German	

Code	Ports position	4
<b>L</b>	Side	

Code	Ports IN/OUT	5
<b>GERMAN FLANGED PORTS</b>		
Side	Type	
<b>BE/BC</b>	PLP 20	4-6,3-7,2-8-9-10,5-11,2 14-16-19-20-24,5-25 27,8-31,5
<b>EUROPEAN FLANGED PORTS</b>		
Side	Type	
<b>EA/EA</b>	PLP 20	4-6,3-7,2-8-9-10,5-11,2
<b>EB/EA</b>	PLP 20	14-16-19-20-24,5-25 27,8-31,5
<b>SAE FLANGED PORTS (SSM)</b>		
Side	Type	
<b>MA/MA</b>	PLP 20	4-6,3-7,2-8-9-10,5-11,2
<b>MB/MA</b>	PLP 20	14-16-19-20
<b>MC/MB</b>	PLP 20	24,5-25-27,8-31,5
<b>SAE FLANGED PORTS (SSS)</b>		
Side	Type	
<b>SA/SA</b>	PLP 20	4-6,3-7,2-8-9-10,5-11,2
<b>SB/SA</b>	PLP 20	14-16-19-20
<b>SC/SB</b>	PLP 20	24,5-25-27,8-31,5

Replaces: 01/10.2003

04/10.2020

## HOW TO ORDER POLARIS 20 MULTIPLE PUMPS

Replaces: 02/07.2006

5	Ports IN/OUT	Code
<b>GAS STRAIGHT THREAD PORTS (BSPP)</b>		
Type		Rear
4-6,3-7,2-8-9-10,5-11,2	PLP 20	<b>GD/GD</b>
14-16-19-20-24,5-25-27,8-31,5	PLP 20	<b>GE/GD</b>
<b>SAE STRAIGHT THREAD PORTS (ODT)</b>		
Type		Rear
4-6,3-7,2-8-9-10,5-11,2	PLP 20	<b>OC/OC</b>
14-16-19-20-24,5 25-27,8-31,5	PLP 20	<b>OD/OC</b>

6	Combination type	Code
Standard		
		<b>S6</b>
Common inlet		
		<b>S7</b>
Separate stages		
		<b>Z6</b>

7	Rotation	Code
Left		
		<b>S</b>
Right		
		<b>D</b>

8	Versions - Outboard bearing options	Code
Without outboard bearing (standard) no code		
		<b>0</b>
With outboard bearing		
		<b>W8</b>
With outboard bearing		
		<b>5</b>
With outboard bearing		
		<b>7</b>
With outboard bearing		
		<b>8</b>
With outboard bearing		
		<b>9</b>

Code	Seals (a)	9
<b>N</b>	Buna (standard)	
<b>V</b>	Viton	
<b>T-PV</b>	Hydrogenated buna HNBR seals with Viton-FKM shaft seals	

Code	Cover options (b)	10
Cast iron mounting flange and rear cover (standard - no code)		
<b>E</b>	Aluminium mounting flange and cast iron rear cover	
<b>L</b>	Cast iron mounting flange and aluminium rear cover	
<b>EL</b>	Aluminium mounting flange and rear cover	

Code	Shaft seal options	11
<b>D</b>	Standard shaft seals with wiper seal	
<b>C1</b>	High back pressure seal	

Code	Shaft arrangement	12
<b>FS</b>	Female spline	

- (a) Choose the seals according to the temperature shown on page 5.
- (b) Mounting flange material on page 61 ÷ 66  
Rear cover material on page 45

04/10.2020

## HOW TO ORDER POLARIS 30 MULTIPLE PUMPS

1	2	3	4	5	6	7	8	9	10	11							
<b>PLP 30-22</b>	-	<b>83</b>	<b>E3</b>	-	<b>L</b>	<b>ED/EB</b>					/						
<b>Front section</b>																	
<b>30-22</b>	-				<b>L</b>	<b>ED/EB</b>					/						
<b>Intermediate section</b>																	
<b>30-22</b>	-				<b>L</b>	<b>ED/EB</b>	-	<b>M6</b>	-	<b>S</b>	<b>0</b>	-	<b>N</b>	-	<b>C</b>	/	<b>FS</b>
<b>Rear section</b>																	

1	Type	Pump Type
21,99 cm <sup>3</sup> /rev (1.34 in <sup>3</sup> /rev)		<b>PLP 30-22</b>
26,70 cm <sup>3</sup> /rev (1.63 in <sup>3</sup> /rev)		<b>PLP 30-27</b>
34,55 cm <sup>3</sup> /rev (2.11 in <sup>3</sup> /rev)		<b>PLP 30-34</b>
39,27 cm <sup>3</sup> /rev (2.40 in <sup>3</sup> /rev)		<b>PLP 30-38</b>
43,98 cm <sup>3</sup> /rev (2.68 in <sup>3</sup> /rev)		<b>PLP 30-43</b>
51,83 cm <sup>3</sup> /rev (3.16 in <sup>3</sup> /rev)		<b>PLP 30-51</b>
61,26 cm <sup>3</sup> /rev (3.74 in <sup>3</sup> /rev)		<b>PLP 30-61</b>
73,82 cm <sup>3</sup> /rev (4.50 in <sup>3</sup> /rev)		<b>PLP 30-73</b>
81,68 cm <sup>3</sup> /rev (4.98 in <sup>3</sup> /rev)		<b>PLP 30-82</b>
91,10 cm <sup>3</sup> /rev (5.56 in <sup>3</sup> /rev)		<b>PLP 30-90</b>

2	Drive shaft	Code
European tapered 1:8		<b>83</b>
European tapered 1:8		<b>84</b>
German tapered 1:5		<b>56</b>
Straight		<b>41</b>
SAE "B" spline		<b>A8</b>
SAE "BB" spline		<b>A5</b>
SAE "B" spline		<b>04</b>
SAE "BB" spline		<b>05</b>
SAE "B" straight		<b>32</b>
SAE "BB" straight		<b>33</b>

3	Mounting flange	Code
European		<b>E3</b>
European		<b>E4</b>
German		<b>B3</b>
SAE "B" 2 bolt		<b>S5</b>
SAE "B" 2 bolt		<b>U3</b>

4	Ports position	Code
Side		<b>L</b>

Code	Ports IN/OUT	5
<b>GERMAN FLANGED PORTS</b>		
Side		Type
<b>BM/BL</b>	PLP 30	22-27-34-38-43 46-51-61-73-82-90
<b>EUROPEAN FLANGED PORTS</b>		
Side		Type
<b>ED/EB</b>	PLP 30	22-27-34-38-43 46-51-61
<b>EF/ED</b>	PLP 30	73-82-90
<b>SAE FLANGED PORTS (SSM)</b>		
Side		Type
<b>MB/MA</b>	PLP 30	22
<b>MC/MB</b>	PLP 30	27-34
<b>MD/MC</b>	PLP 30	38-43-46-51
<b>ME/MD</b>	PLP 30	61-73-82
<b>MF/ME</b>	PLP 30	90
<b>SAE FLANGED PORTS (SSS)</b>		
Side		Type
<b>SB/SA</b>	PLP 30	22
<b>SC/SB</b>	PLP 30	27-34
<b>SD/SC</b>	PLP 30	38-43-46-51
<b>SE/SD</b>	PLP 30	61-73-82
<b>SF/SE</b>	PLP 30	90
<b>GAS STRAIGHT THREAD PORTS (BSPP)</b>		
Side		Type
<b>GF/GF</b>	PLP 30	22-27-34-38-43-46-51
<b>GG/GF</b>	PLP 30	61-73
<b>GH/GG</b>	PLP 30	82-90
<b>SAE STRAIGHT THREAD PORTS (ODT)</b>		
Side		Type
<b>OF/OD</b>	PLP 30	22-27-34
<b>OG/OF</b>	PLP 30	38-43-46-51
<b>OH/OG</b>	PLP 30	61-73-82-90

01/10.2003

## HOW TO ORDER POLARIS 30 MULTIPLE PUMPS

Replaces: 01/10.2003

6	Combination type	Code
	Standard	<b>M6</b>

7	Rotation	Code
	Left	<b>S</b>
	Right	<b>D</b>

8	Versions - Outboard bearing options	Code
	Without outboard bearing (standard) no code	<b>0</b>

9	Seals (a)	Code
	Buna (standard)	<b>N</b>
	Viton	<b>V</b>

10	Shaft seal options	<b>O</b> Code
	Standard seal with wiper seal	<b>D</b>
	High back pressure seal	<b>C1</b>

11	Shaft arrangement	Code
	Female spline	<b>FS</b>

- (a) Choose the seals according to the temperature shown on page 5.

04/10.2020

## HOW TO ORDER POLARIS DOUBLE PUMPS DIFFERENT GROUPS

1	2	3	4	5	6	7	8	9	10	11				
<b>PL 30-22</b>	-	<b>83</b>	<b>E3</b>	-	<b>L</b>	<b>ED/EB</b>	/							
<b>Front section</b>														
<b>20-4</b>	-			<b>L</b>	<b>EA/EA</b>		<b>S</b>	<b>0</b>	/	<b>FS</b>	-	<b>L</b>	-	<b>N</b>
<b>Rear section</b>														

1	2	3	4	5	6	7	8	9	10	11					
<b>PLP 30-22</b>	-	<b>83</b>	<b>E3</b>	-	<b>L</b>	<b>ED/EB</b>	-	<b>52</b>	/						
<b>Front section</b>															
<b>10-1</b>	-			<b>L</b>	<b>BB/BA</b>	-		<b>S</b>	<b>0</b>	/	<b>FS</b>	-	<b>L</b>	-	<b>N</b>
<b>Rear section</b>															

1	2	3	4	5	6	7	8	9	10	11					
<b>PLP 20-4</b>	-	<b>82</b>	<b>E2</b>	-	<b>L</b>	<b>EA/EA</b>	-	<b>51</b>	/						
<b>Front section</b>															
<b>10-1</b>	-			<b>L</b>	<b>BB/BA</b>	-		<b>S</b>	<b>0</b>	/	<b>FS</b>	-	<b>EL</b>	-	<b>N</b>
<b>Rear section</b>															

1	<b>Type</b>	Pump Type
	The same of multiple pumps	<b>PLP</b>

2	<b>Drive shaft</b>	Code
	The same of multiple pumps	...

3	<b>Mounting flange</b>	Code
	The same of multiple pumps	...

4	<b>Ports position</b>	Code
	Side	<b>L</b>

5	<b>Ports IN/OUT</b>	Code
	The same of multiple pumps	../..

6	<b>Combination type</b>	Code
	PLP30/20 Standard - No code	<b>N6</b>
	PLP30/20 Common inlet	<b>N7</b>
	PLP30/20 Separate stages	<b>Z6</b>
	PLP30/10 Standard - No code	<b>Q6</b>
	PLP30/10 Common inlet	<b>Q7</b>
	PLP20/10 Standard - No code	<b>T6</b>
	PLP20/10 Common inlet	<b>T7</b>
	PLP20/10 Separate stages	<b>Z6</b>

Code	<b>Rotation</b>	7
<b>S</b>	Left	
<b>D</b>	Right	

Code	<b>Versions - Outboard bearing options</b>	8
...	The same of multiple pumps	

Code	<b>Shaft arrangement</b>	9
<b>FS</b>	Female spline	

Code	<b>Cover options (a)</b>	10
	Cast iron mounting flange and rear cover (standard - no code)	
<b>E</b>	Aluminium mounting flange and cast iron rear cover (only for PLP20/10)	
<b>L</b>	Cast iron mounting flange and aluminium rear cover	
<b>EL</b>	Aluminium mounting flange and rear cover (only for PLP20/10)	

Code	<b>Seals</b>	11
	The same of multiple pumps	

- (a) Mounting flange material:  
 PLP 20 on page 61 ÷ 66 - PLP 30 on page 67 ÷ 69  
 Rear cover material:  
 PLP 10 on page 44 - PLP 20 on page 45

02/07.2006

Our policy is one of continuous improvement in product. Specification of items may, therefore, be changed without notice.



PL 04 T A

Edition: 04/10.2020

Replaces: PL 03 T A



Headquarters:

**CASAPPA S.p.A.**

Via Balestrieri, 1

43044 Lemignano di Collecchio

Parma (Italy)

Tel. (+39) 0521 30 41 11

Fax (+39) 0521 80 46 00

E-mail: [info@casappa.com](mailto:info@casappa.com)

[www.casappa.com](http://www.casappa.com)





Our international sales network covers every jurisdiction. Our global shipping partners mean you can be sure we're on hand whenever you need us.

## **Zeus Hydratech Ltd**

Unit 35  
Old Mills Industrial Estate  
Paulton  
Bristol, BS39 7SU  
United Kingdom

T. +44 (0) 1172 130042  
E: [info@zeushydratech.com](mailto:info@zeushydratech.com)  
W. [www.zeushydratech.com](http://www.zeushydratech.com)