



POWERFUL
ACCURATE

CONTINENTAL HYDRAULICS

VED05MJ

DIRECTIONAL CONTROL VALVES WITH OBE & POSITION FEEDBACK

PRECISE
DURABLE
ROBUST

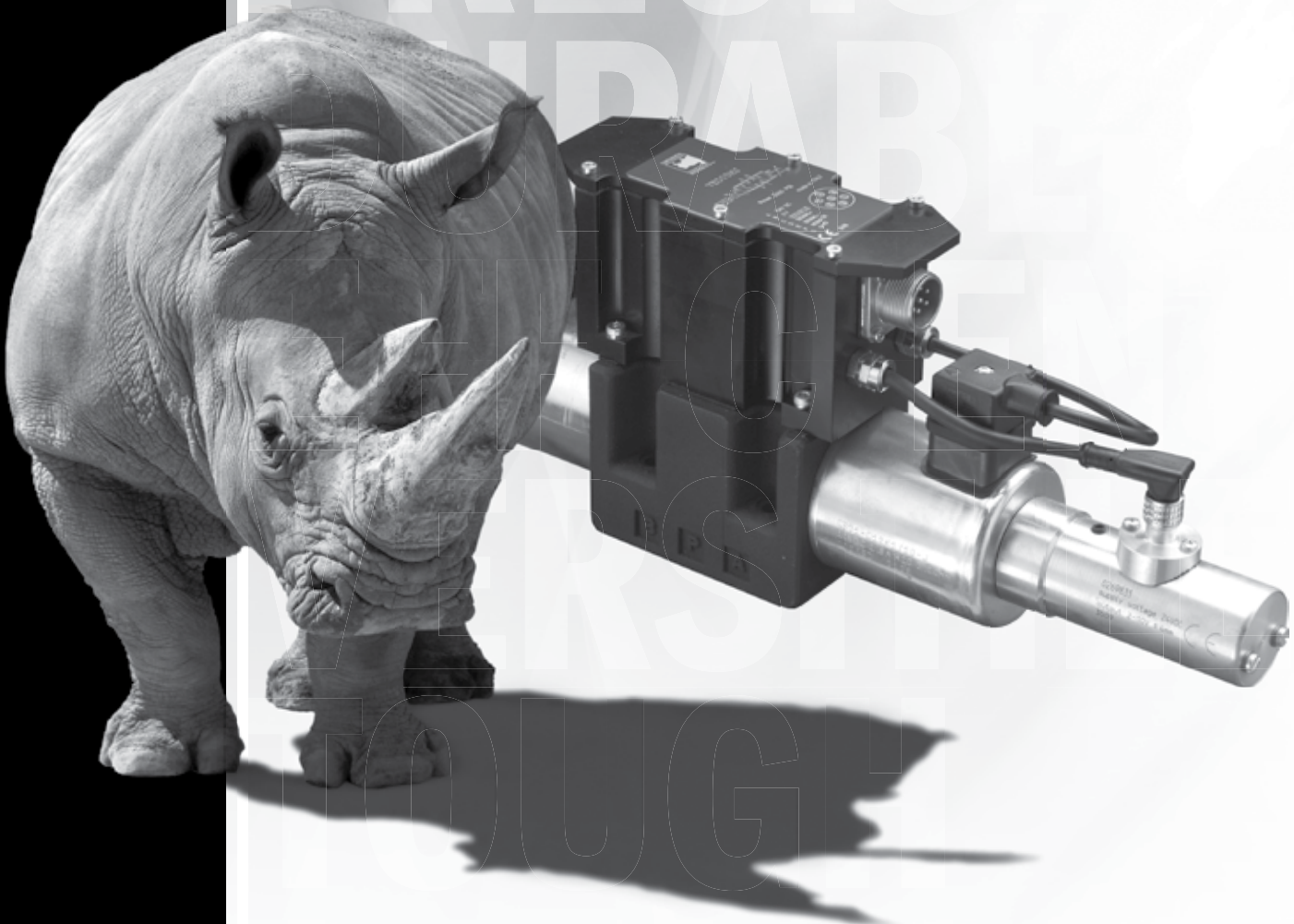

VED05MJ - DIRECTIONAL CONTROL VALVES WITH OBE & POSITION FEEDBACK

VED05MJ

DIRECTIONAL CONTROL VALVES WITH OBE & POSITION FEEDBACK

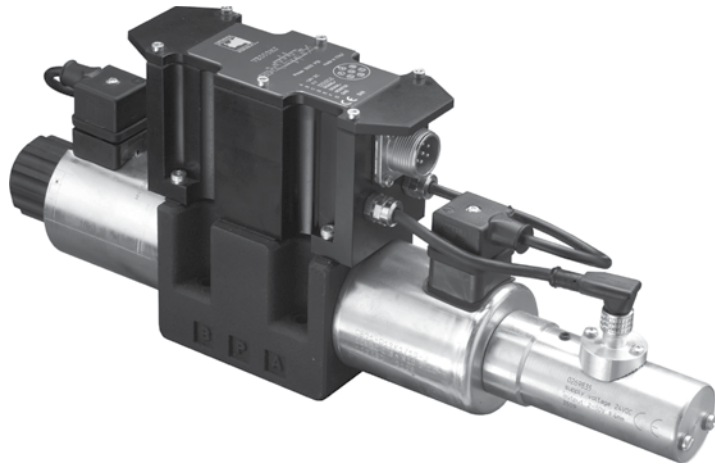

DESCRIPTION

Continental Hydraulics VED05MJ direct operated 4-way proportional valves with On-Board Digital Amplifier and Spool Position sensing, conform to NFPA D05 and ISO 4401 mounting standards.

OPERATION

These valves are designed to control the direction and oil flow rate based on the degree of command signal supplied to the On-Board Amplifier. In event of a loss in electrical power, the centering springs will return the valve spool to the center position.

This Valves series is also available with a Fail-Safe option.

The Spool Position Sensor circuit improves the overall valve performance by reducing hysteresis and improving response times.

The On-Board microprocessor controls all the valve functions and is pre-set to optimal valve performance.

In-field adjustments can be performed via software to customize the parameters based on your application needs.

TYPICAL PERFORMANCE SPECIFICATIONS

MAXIMUM OPERATING PRESSURE:	P - A - B Ports	4600 psi	320 bar
	T Port	3000 psi	210 bar
FLOW CAPACITY WITH ΔP 145 PSI (10 BAR)	AC/FC/ZC 50	13 gpm	50 l/min
	AC/FC/ZC 75	20 gpm	75 l/min
MOUNTING SURFACE		NFPA D05 ISO 4401-05-04-0-05	
HYSTERESIS	% of Q max	< 0.2%	
REPEATABILITY	% of Q max	< ± 0.1%	
THRESHOLD		< 0.1%	
POWER SUPPLY		24V DC (19V to 35V, ripple max 3 Vpp)	
	Max Current	3A	
CONNECTION		7 pin (6+ ground) metal	
PROTECTION	IEC 60529	IP 65 / 67	
WEIGHT:	Single Solenoid	12.3 lbs	5.6 Kg
	Dual Solenoid	15.7 lbs	7.1 Kg

RANGE TEMPERATURES:	Ambient	- 4 to +130° F	-20 to +54° C
	Fluid	- 4 to +180° F	-20 to +82° C
FLUID VISCOSITY	Range	60-1900 SUS	10- 400 cSt
	Recommended	120 SUS	25 cSt
FLUID CONTAMINATION		ISO 4406:1999 class 18/16/13	

IDENTIFICATION CODE

VED05MJ - [] [] - [] - [] - [] [] **D** - [] _____ DESIGN LETTER

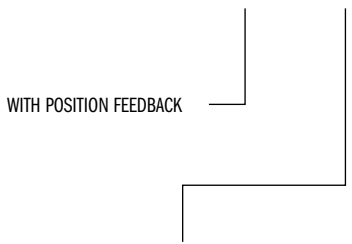

FUNCTION	
3	<p>Dual operator 3 position spring centered</p>
5	<p>Single operator 2 position spring centered</p>

CONNECTION	
OBW	On board electronics 7 pin - no external enable required (STD)
OBC	On board electronics 7 pin external enable on pin C required

REFERENCE SIGNAL	
E0	Voltage ± 10V (STD)
E1	Current 4 - 20 mA

SEAL	
A	Buna (STD)
G	Viton

NOMINAL FLOW (with Δp P-T 145 psi)	
50	50 l/min (13 gpm)
75	75 l/min (20 gpm)
70/35	Asymmetrical spool: 70 l/min (13 gpm) on P-A 35 l/min (20 gpm) on P-B

TYPICAL ORDERING CODE:
VED05MJ-3AC-50-A-OBWE0D-A

SPOOLS				
NAME	SYMBOLS	DESCRIPTION	APPLICATION	FUNCTION MATCHING
AC		METER IN / METER OUT	MOTION CONTROL	3, 5
FC		METER IN / METER OUT		3, 5
ZC		METER IN / METER OUT		3

VED05MJ - DIRECTIONAL CONTROL VALVES WITH OBE & POSITION FEEDBACK

PERFORMANCE CURVES - FLOW GAIN

Typical flow rate curves at constant Δp related to the reference signal and measured for the available spools and obtained after linearization in factory of the characteristic curve through the digital amplifier.

The Δp values are measured between P and T (full loop) valve ports.

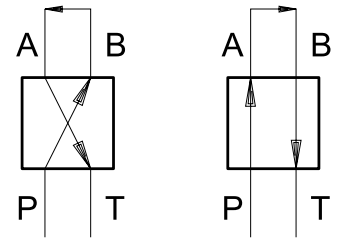

AC-50, FC-50

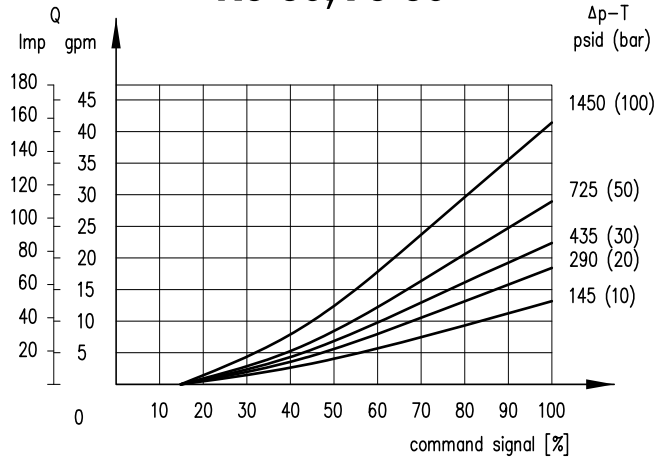

ZC-50

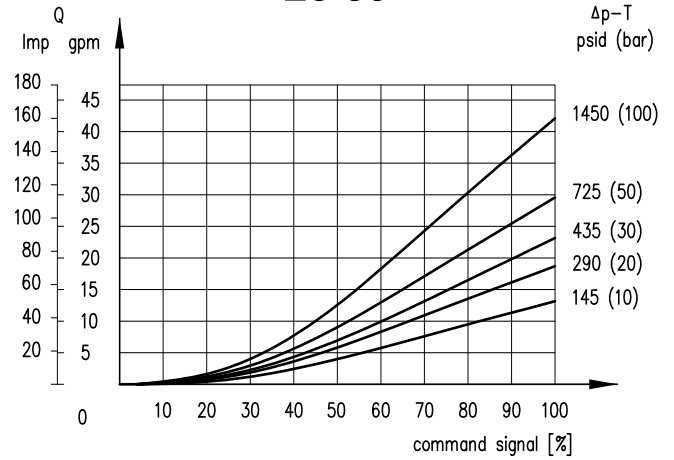

AC-75, FC-75

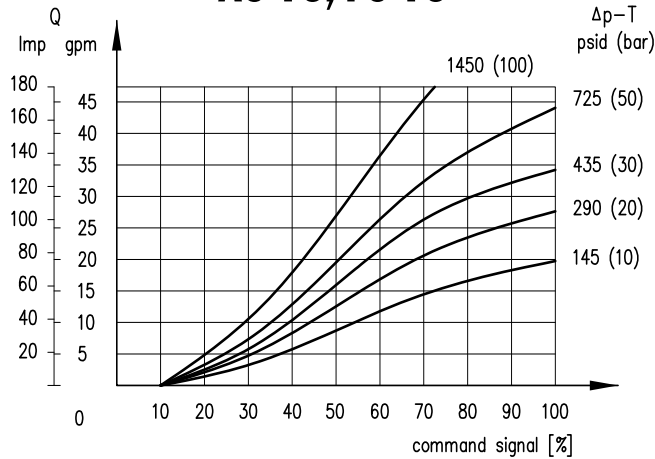

ZC-75

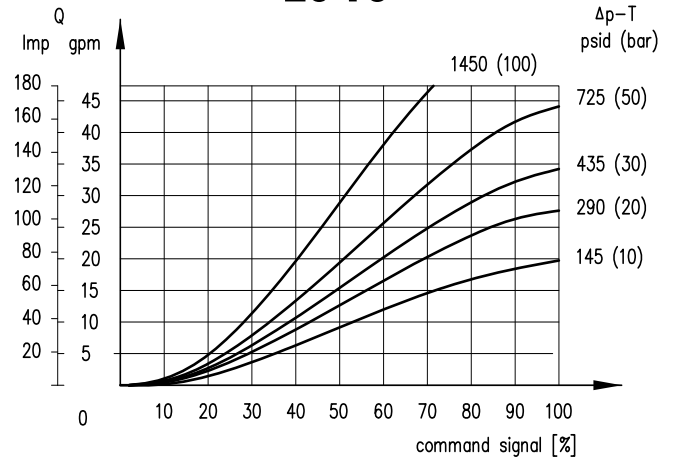

NOTES:

Curves obtained with mineral oil with viscosity of 170 sus (36 cSt) at 122°F (50°C) and dedicated OBE.

PRESSURE GAIN FOR SPOOLS “ZC”

The diagram shows the valve pressure gain, expressed as % of the ratio between the port pressure variation in A or B (Δp_{AB}) and the P system pressure, according to the reference signal. In practice, the pressure gain states the valve reaction towards external disturbances aimed at changing the actuator position.

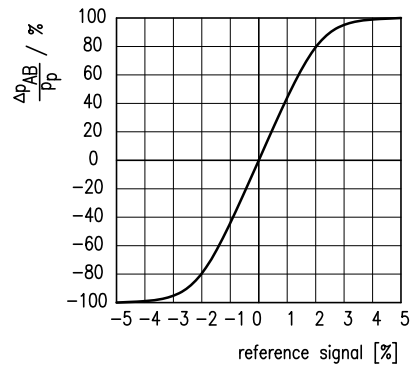

FREQUENCY RESPONSE

(TYPICAL)

Frequency response and response time obtained with mineral oil with viscosity of 170 SUS (36 cSt) at 122°F (50°C) and with on-board electronics and Δp (P-T) 143 psi.

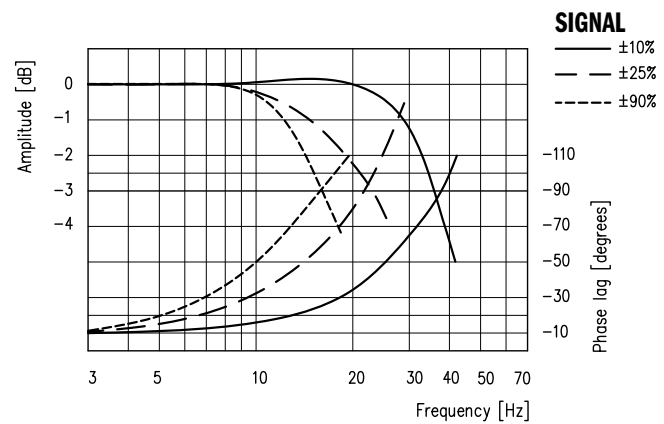

RESPONSE TIME

	ENERGIZING				DE-ENERGIZING			
	0 ▶ 25%	0 ▶ 50%	0 ▶ 75%	0 ▶ 100%	25% ▶ 0	50% ▶ 0	75% ▶ 0	100% ▶ 0
TIMES [ms]	25	35	35	40	25	35	45	45

OVERALL AND MOUNTING DIMENSIONS

VED05MJ-3

Dimensions in mm [IN]

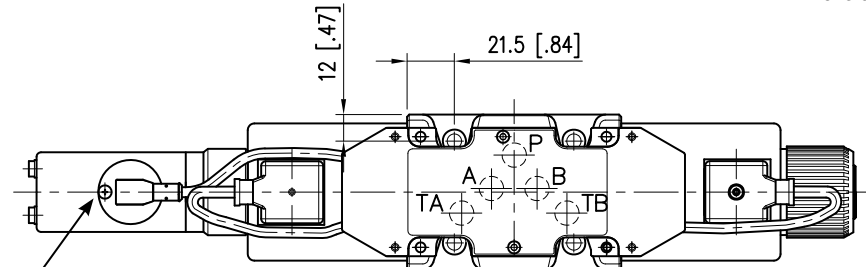

Adjustment sealing performed at factory.

Do not disassemble the transducer.

Main connection 7 - pin male
MIL-C-5015-G (DIN 43563 metal)

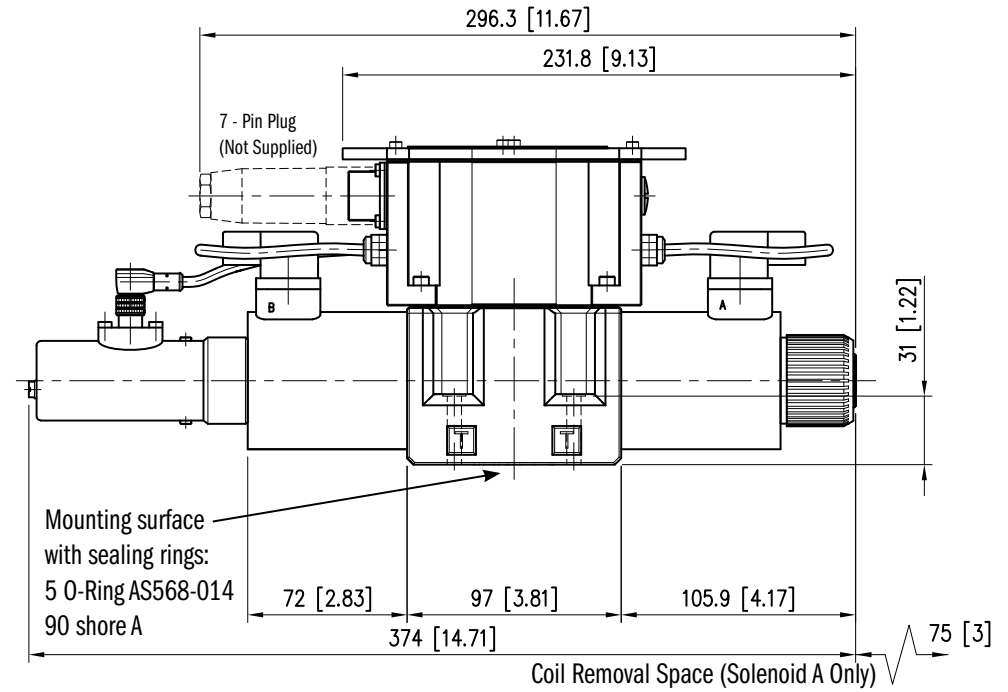
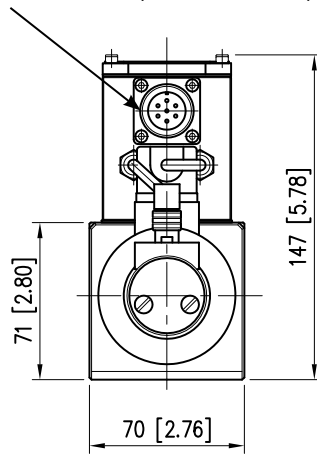

VED05MJ-5



In order to avoid electro-magnetic noises and fulfill the EMC regulations, a 7 pin metal plug according to MIL-C-5015 G should be used instead of the standard plastic 6+PE plug.

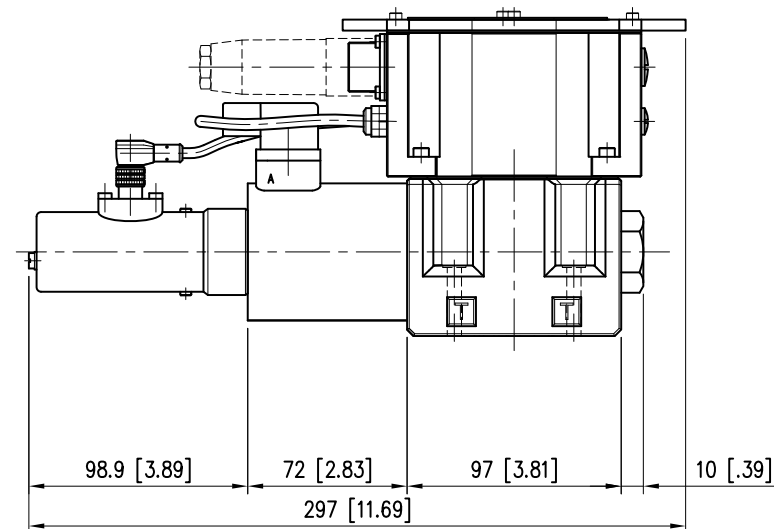

The plug is not supplied, but can be ordered separately.

ELECTRICAL CHARACTERISTICS

The proportional valve is controlled by a digital amplifier (driver), which incorporates a microprocessor that controls all the valve functions.

THE STANDARD VALVE IS SET AT THE FACTORY WITH:

- UP/DOWN ramp at zero value
- No deadband compensation
- Max valve opening (100% of spool stroke)

It is possible to customize these and others parameters using the optional kit, LINPC-USB to be ordered separately (see related literature).

THE DIGITAL DRIVER ENABLES THE VALVE TO REACH BETTER PERFORMANCE COMPARED TO THE ANALOG VERSION, AND GIVES:

- Reduced response times
- Optimization and reproducibility of the characteristic curve, optimized in factory for each valve
- Complete interchangeability in case of valve replacement
- Opportunity to set, via software, the functional parameters
- Opportunity to perform a diagnostic program by means of the LIN connection
- High immunity to electromagnetic interference

The electronic card is available with (OBC) or without (OBW) external enabling signal feature.

POWER SUPPLY	24V DC (19V to 35V, ripple max 3Vpp)	
ABSORBED POWER	70 W	
MAX CURRENT	3A	
DUTY CYCLE	100%	
MAIN CONNECTOR	7 pin MIL-C-5015-G (DIN 43563)	
ELECTROMAGNETIC COMPATIBILITY (EMC)	Emission	IEC EN 61000-6-4
	Immunity	IEC EN 61000-6-2
PROTECTION AGAINST ATMOSPHERIC AGENTS	IEC 60529	IP 65 / 67
ELECTRICAL PROTECTION	Overload electronics overheatingLVDT sensor error power failure or < 4mA	

E0 - VOLTAGE

COMMAND SIGNAL (DIFFERENTIAL)	Single Solenoid	0 - 10V DC
	Dual Solenoid	±10V DC
IMPEDANCE	> 50 kΩ	

E1 - CURRENT

COMMAND SIGNAL	4 - 20 mA
IMPEDANCE	500 Ω

E0 VERSION - VOLTAGE REFERENCE SIGNAL

This is the most common version; it makes the valve completely interchangeable with the traditional proportional valves with analog type integrated electronics. The valve has only to be connected as indicated below.

The input signal is differential type and drives the valve as shown in the chart below. The spool stroke is proportional to UD - UE. If only one input signal (single-end) is available, the pin B (0V power supply) and the pin E (0V reference signal) must be connected through a jumper and both connected to GND, electric panel side.

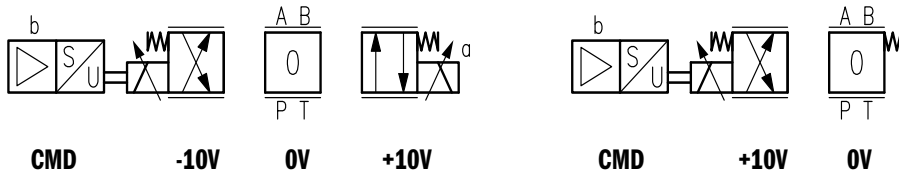

A	24V	Power supply positive. Use an external fuse 5A/50V fast type for protecting electronics.
B	0V	Power supply zero (0V)
C	NC or 24V	OBW Version: Not wired OBC Version: Valve enable
D	± 10V or 0 - 10V	Differential command signal (+V)
E	0V	Differential command signal (-V)
F	2-6-10V or 6-10V	Output feedback monitor
G	GND	Protective ground

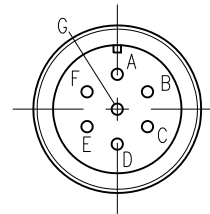

E1 VERSION - CURRENT REFERENCE SIGNAL

The current reference signal is supplied in range of 4 - 20 mA and drives the valve as shown in the chart below. If the current drops to less than 4 mA, the card de-energizes the coils and the valve will go to rest position. The valve will restart when the command signal rises into the 4 - 20 mA range.

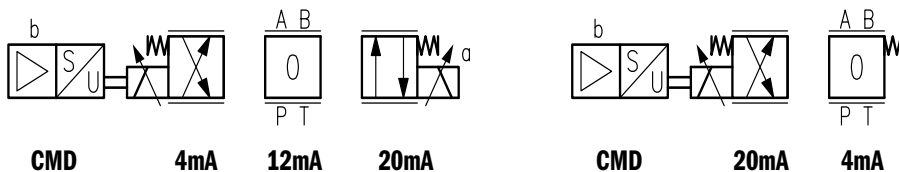

A	24V	Power supply positive. Use an external fuse 5A/50V fast type for protecting electronics.
B	0V	Power supply zero (0V)
C	NC or 24V	OBW Version: Not wired OBC Version: Valve enable
D	4 - 20 mA	Command signal
E	0V	Return
F	2 - 6 - 10V or 6 - 10V	Output feedback monitor
G	GND	Protective ground

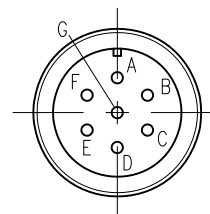

WIRING:

Connections must be made via the 7 pin plug mounted on the amplifier.

Recommended Cable Sizes Are:

POWER SUPPLY

18 AWG (0.75 mm²)
for cables up to 65 ft (20 m).

16 AWG (1.00 mm²)

for cables up to 130 ft (40 m).

SIGNAL CABLES

20 AWG (0.50 mm²)

A suitable cable would have 7 wires, a separate shield for the signal wires and an overall shield.

PIN C:

The Pin C is reserved for the Enable feature. In OBC card version, the Enable feature is external; Pin C has to be connected with 24V.

In the OBW card version, Pin C is not to be connected, because the enable signal is run directly from the card.

PIN F:

For reading this value as a feed-back monitor signal, the card must be enabled. This value has to be read on Pin B (0V).

When the card is disabled, the Pin F referred to Pin B does not mean a MONITOR value, but shows a voltage of 2.7 V of the LIN-bus communication.

When a failure or an LVDT error is detected, the drive brings the valve to the rest position and locks it. In this state the Pin F, referring to the Pin B, shows a value of 0V.

To reset an LVDT error the card must be disabled and enabled again.

SINGLE SOLENOID		
Pin F	Pin D	
	E0	E1
-	-	-
6V	0V	4mA
+10V	+10V	20mA

DUAL SOLENOID		
Pin F	Pin D	
	E0	E1
+10 V	-10V	4mA
6V	0V	12mA
2V	+10V	20mA

OBW OR OBC VERSION?

The standard option, code OBW, is programmed for internal enable. The enable signal is taken directly from the power supply of the valve. The card is enabled as soon as supply power is applied to Pins A and B.

Apply command signal to the valve and the output drivers energize the coil. The power supply must be switched off to disable the output to the valve.

The OBC option is programmed for the external enable feature. A 24 V signal must be applied to Pin C to enable the output drivers to energize the valve coils.

The valve operation can be stopped by simply removing the enable signal from Pin C.

OBW CARD VERSION (STD)

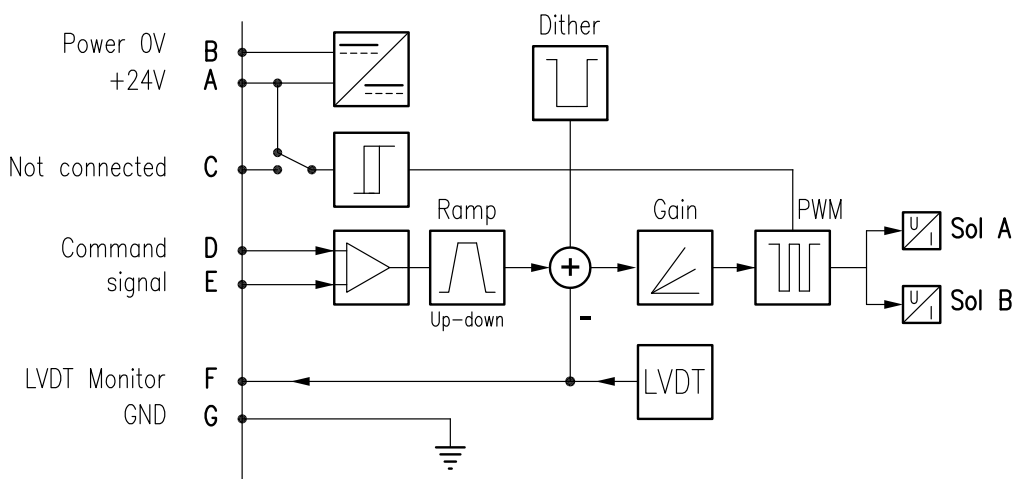

OBC CARD VERSION

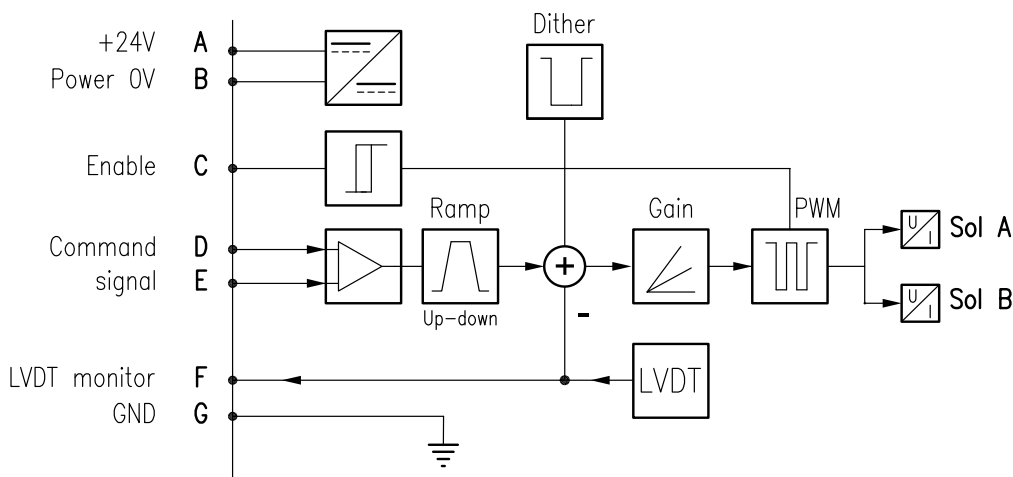

APPLICATION DATA

FLUIDS

All pressure drops shown on these data pages are based on 170 SUS fluid viscosity and 0.87 specific gravity. For any other specific gravity (G1) the pressure drop (ΔP) will be approx. $\Delta P_1 = \Delta P (G_1/G)$. See the chart for other viscosities.

FLUID VISCOSITIES	Cst	10	14.5	32	36	43	54	65	76	86	108	216	324	400
	SUS	60	75	150	170	200	250	300	350	400	500	1000	1500	1900
MULTIPLIER		0.77	0.81	0.97	1.00	1.04	1.10	1.15	1.20	1.24	1.31	1.56	1.72	1.83

Use mineral oil-based hydraulic fluids HL or HM type, according to ISO 6743-4. For these fluids, use NBR seals. For fluids HFDR type (phosphate esters) use FPM seals (code V). For the use of other kinds of fluid such as HFA, HFB, HFC, please consult our technical department.

Using fluids at temperatures higher than 180 degrees F causes the accelerated degradation of seals as well as degradation of the fluids physical and chemical properties.

From a safety standpoint, temperatures above 130 degrees F are not recommended.

INSTALLATION

VED05MJ valves can be installed in any position without impairing correct operation.

Ensure that there is no air in the hydraulic circuit.

Valves are fixed by means of screws or tie rods on a flat surface with planarity and roughness equal to or better than those indicated in the relative symbols. If minimum values are not observed, fluid can easily leak between the valve and support surface.

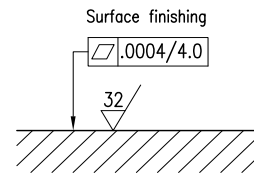

7 PIN PLUG

VEA-3P7P-A	Straight plug 7 pin plastic housing	264893
VEA-3P7M-A	Straight plug 7 pin metal housing	265947

BOLT KITS

BD05-163-B	Valve Only	1013160
-------------------	------------	---------

NOTES:

1. Bolt kit consists of: Qty 4 screws 1/4-20 UNC x 1-3/4 and lock washers
2. The recommended torque value for the fasteners is: 6 lb.ft. (8.13 Nm)

SEAL KIT

BUNA SEAL KIT V*D05M DES B	1013142
VITON SEAL KIT V*D05M DES B	1013146

SUBPLATES

AD05JESPS16S	Aluminium	SAE-16	1013140
DD05JESPS16S	Ductile	SAE-16	1013141

NOTES:

1. Max pressure aluminium subplate: 3000 psi max pressure ductile subplate: 5000 psi
2. Always verify that subplate port size is proper for the application
3. Kit consists of 1 subplate and 2 SAE-04 plugs for pilot and drain ports as they are unused



POWERFUL
ACCURATE
INNOVATIVE
PRECISE
DURABLE
EFFICIENT
VERSATILE

ABOUT CONTINENTAL HYDRAULICS

Rugged, durable, high-performance, efficient—the reason Continental Hydraulics' products are used in some of the most challenging applications across the globe. With a commitment to quality customer support and innovative engineering, Continental's pumps, valves, power units, mobile and custom products deliver what the markets demand. Continental has been serving the food production, brick and block, wood products, automotive and machine tool industries since 1962. Learn how our products survive some of the most harsh environments.

SALES@CONTHYD.COM

5505 WEST 123RD STREET • SAVAGE, MN 55378-1299 / PH: 952.895.6400 / FAX: 952.895.6444 / WWW.CONTINENTALHYDRAULICS.COM

CONTINENTAL



HYDRAULICS.